

ZONING

12 Attachment 1

Appendix

FIGURE 1

Airfield Clearances

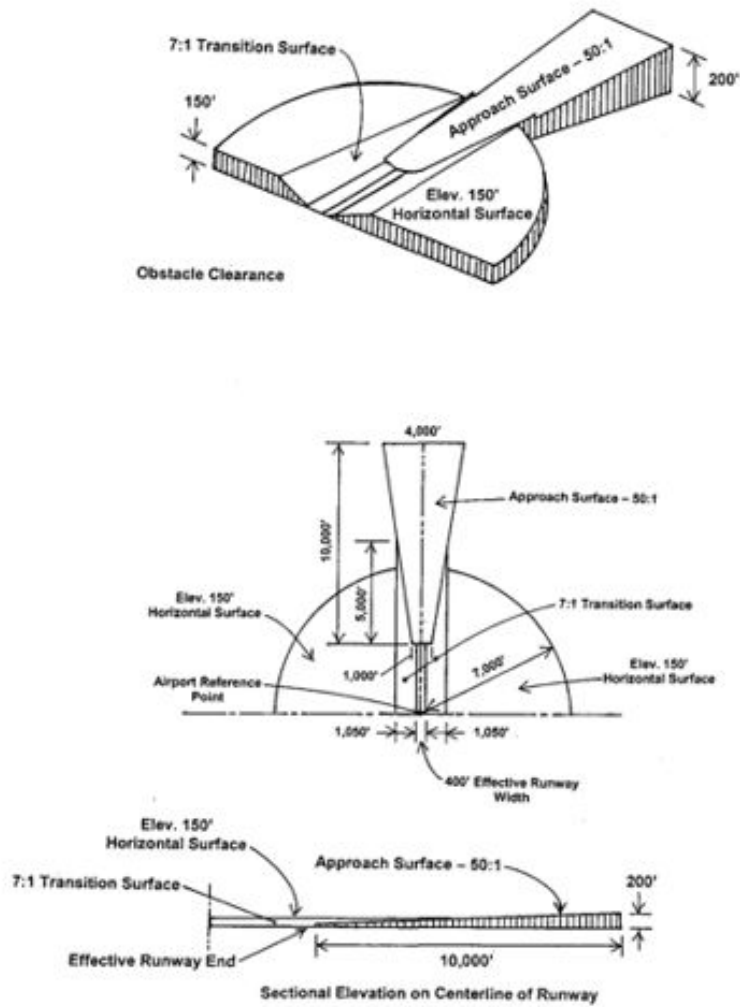



ZONING

FIGURE 3

Typical Parking Lot Landscaping

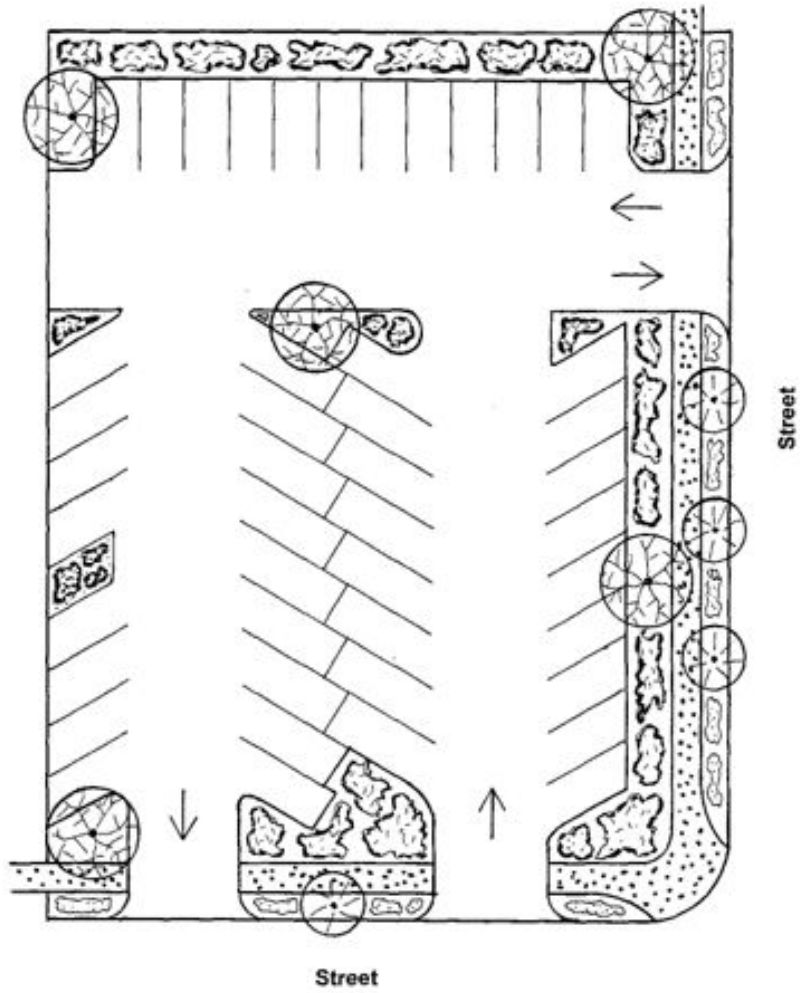

SANTA MARIA CODE

FIGURE 4

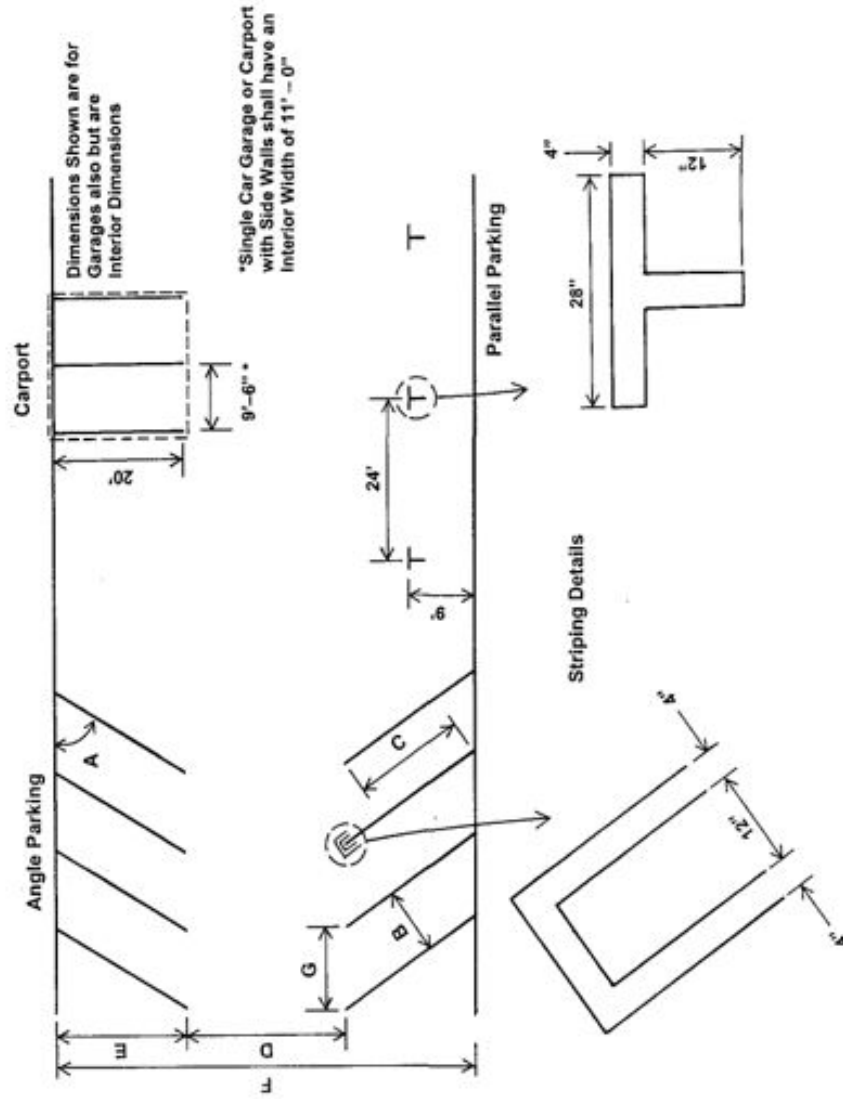

ZONING

FIGURE 5

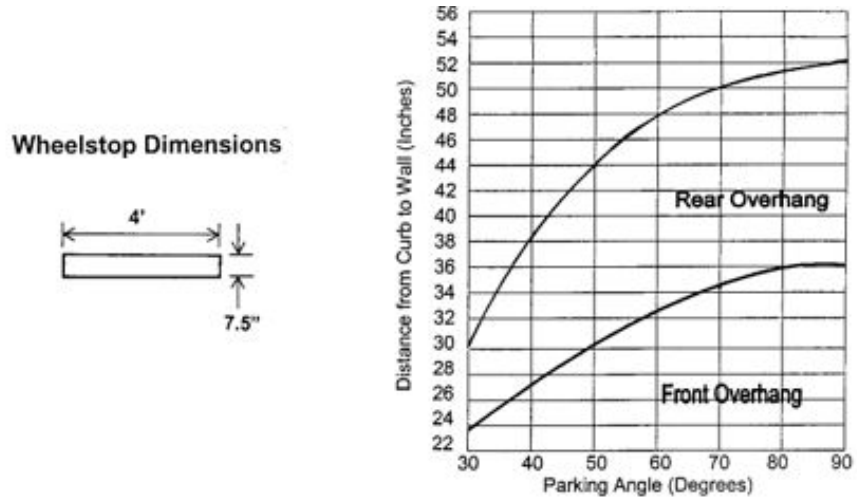

Rear Overhang Clearance:

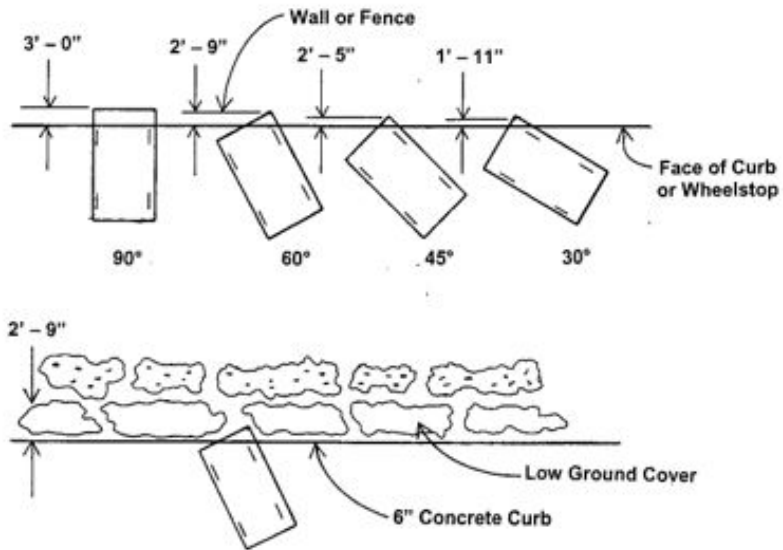

SANTA MARIA CODE

FIGURE 6

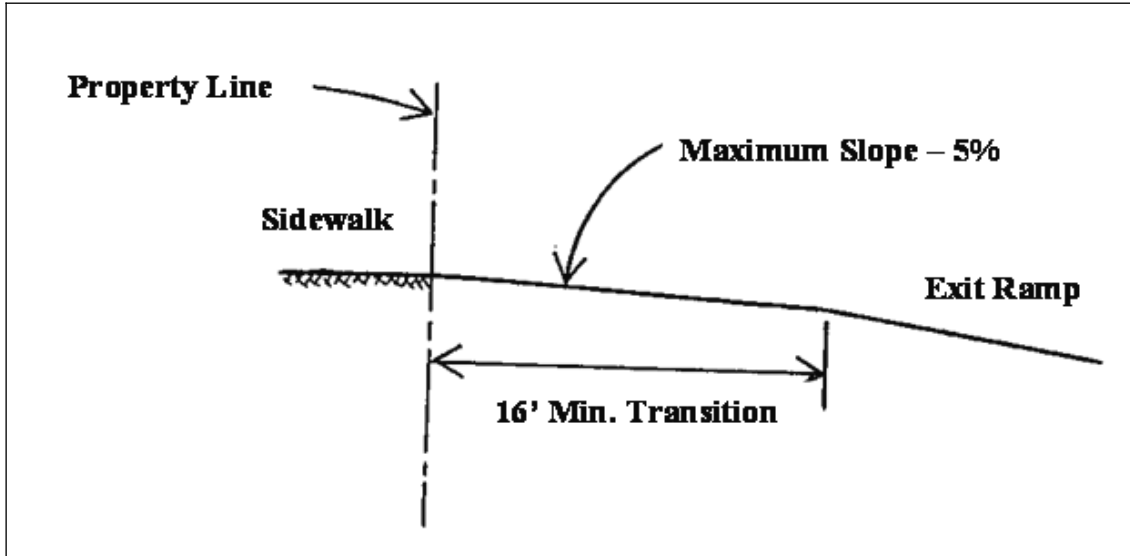
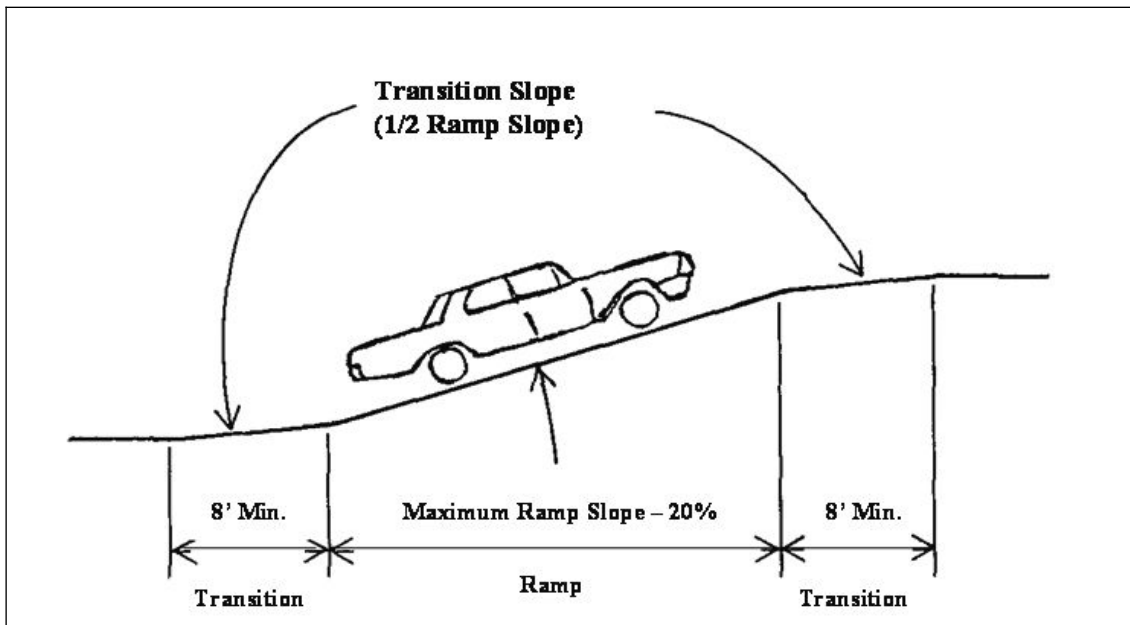

FIGURE 7



(Ord. 2017-01 § 90, eff. 3/9/17)