

# ZONING

## 85 Attachment 9

### Town of Brookhaven Ronkonkoma Hub Land Use and Implementation Plan

RONKONKOMA HUB TOD  
NOT TO SCALE

REGULATING PLAN

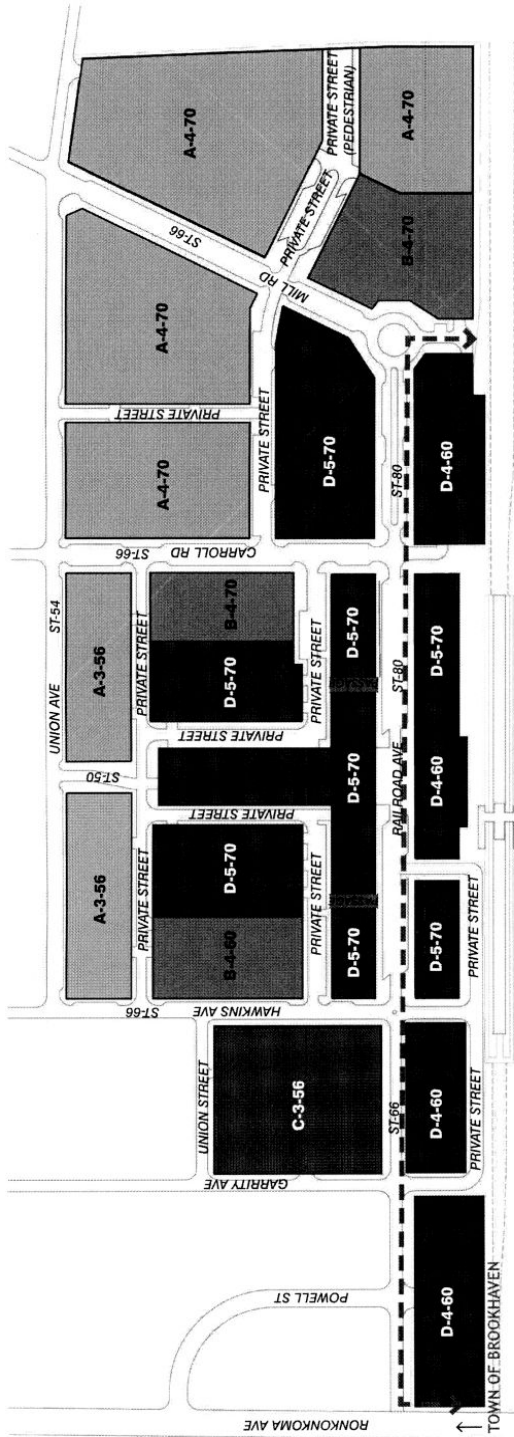

- Notes:**
1. The principal frontage shall be the side of the block that is of greatest length, abuts a public street, or that is otherwise approved by the Planning Board at site plan approval. There shall be one principal frontage per block. *Exception:* in Subdistrict C, Hawkings Avenue shall be the principal frontage.
  2. The secondary frontage shall be any side of a block that abuts a public street but is not a principal frontage. *Exception:* in Subdistrict C, Railroad Avenue shall be the only secondary frontage below are met.
  3. Private street locations illustrated here may be adjusted, so long as the requirements of note 5 are met.
  4. Subdistricts shall be construed to extend to the centerlines of adjoining streets.
  5. Within the subdistricts, blocks shall be subdivided with public or private streets such that the total perimeter of the block is not less than 1300 linear feet, and does not exceed 1600 linear feet. A clearly defined public pedestrian pathway connecting two different streets shall be construed as subdividing the block.

**Form & use**

**C-3-56 (example)**

- Maximum height in feet
- Maximum height in stories above average grade
- Subdistrict

**ST-66 (example)**

Required public right-of-way width in feet

**Street types**

Subdistrict A  
Neighborhood  
Subdistrict B  
Downtown living  
Subdistrict C  
Marketplace  
Subdistrict D  
Main Street

- LEGEND**
- Subdistrict A
  - Neighborhood
  - Subdistrict B
  - Downtown living
  - Subdistrict C
  - Marketplace
  - Subdistrict D
  - Main Street
- Residential uses prohibited within the dashed boundary. See Subdistrict D requirements.

# BROOKHAVEN CODE

## RONKONKOMA HUB TOD

## ILLUSTRATIVE DEFINITIONS

### STREET ASSEMBLY

This illustration depicts a generic street assembly, consisting of the street type (which defines the lot lines), a designated open space (optional, where approved by the Town), and a setback established by the build-to-zone.

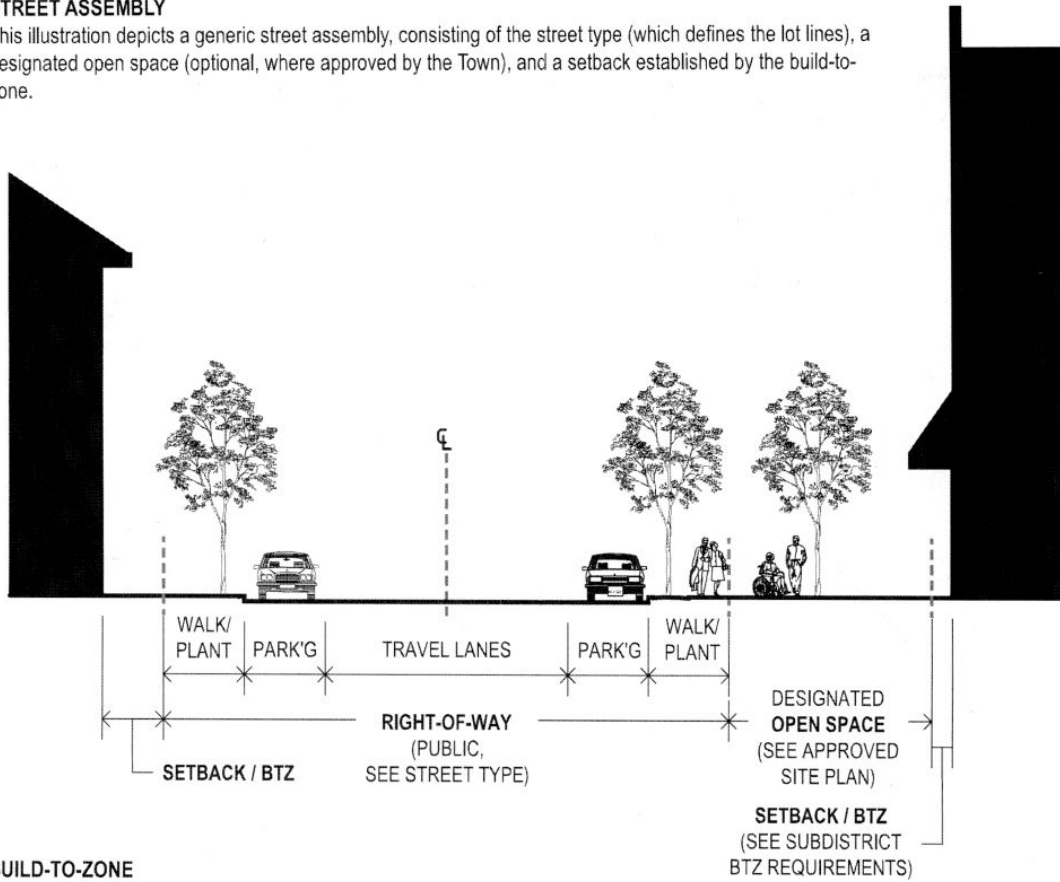

### BUILD-TO-ZONE

This illustration depicts a principal building which meets a 65% build-to requirement. In this illustration, the BTZ is variable between a maximum and minimum requirement, as is common in this Code.

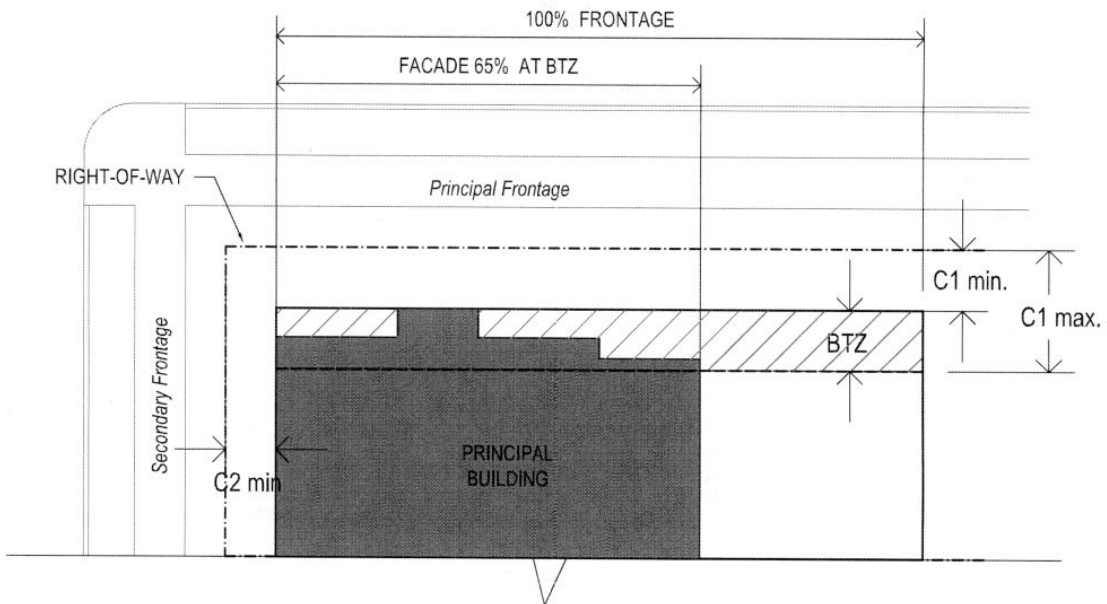

# ZONING

## TABLE 1A. SUBDISTRICT A REQUIREMENTS

RONKONKOMA HUB TOD

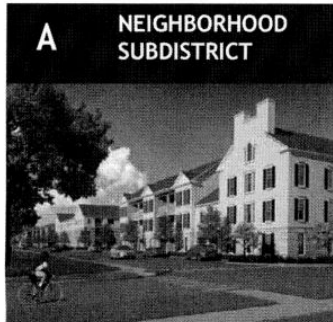

### A NEIGHBORHOOD SUBDISTRICT

The Neighborhood subdistrict is a predominantly residential area with medium to high density building types. It allows for a limited amount of ground floor commercial use and live/work units. It provides a transition between single family homes and more compact mixed use areas.

#### A. USE (see also Table 1)

Residential	Permitted at all levels.
Commercial	Permitted at first floor. Limited to a maximum of 15% of linear principal frontage per block.

#### B. BUILDING CONFIGURATION

B1. Maximum height, feet	Varies. See regulating plan.
B2. Max. height, stories	Varies. See regulating plan.
B3. Minimum height, stories	2 stories

#### C. ALIGNMENT- PRINCIPAL BUILDINGS

C1. Principal Frontage BTZ	12 ft. min. 12 ft. max.
C2. Secondary Frontage BTZ	2 ft. min. 12 ft. max
C3. Setback from TOD District boundary	25 ft. min.
C4. Build-to frontage	65% min. at build-to-zone.

#### D. ACCESSORY BUILDINGS

Accessory buildings shall be set back from the lot line as specified herein.

D1. Principal Frontage	25 ft. min.
D2. Secondary Frontage	10 ft. min.
D3. Rear lot line setback from TOD District	25 ft. min.

#### E. PARKING REQUIREMENTS

See Table 5

#### F. STREETScape

Street trees	30' o.c. average
Furnishings	100' o.c. average

#### BUILDING CONFIGURATION

- Height (B1) is measured from average grade to top of parapet or top of ridge.
- The number of stories (B2) shall be measured from the average grade and shall exclude attics, basements, and other areas below the average grade.

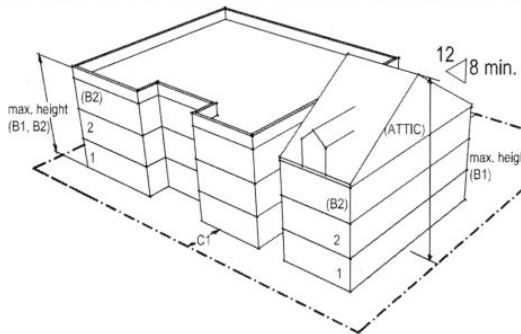

#### ALIGNMENT

- Ground floor façades of principal buildings shall be built within the frontage build-to zones (C1, C2) to the minimum specified width (C4).

Exception: Where there is a designated outdoor space between the street lot line and a building, the build-to zone for such building shall be measured from the inner line (i.e. the line opposite and farthest from the lot line) of such designated outdoor space.

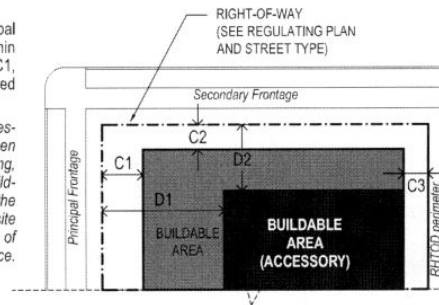

#### PARKING PLACEMENT

- Covered and/or surface parking spaces may only be provided where shown in the diagram at right.
- Underground parking is permitted anywhere within the buildable lot area.
- Garage entries from the Principal Frontage must serve a minimum of 8 parking spaces. Entrances to individual one and two car garages are not permitted on the Principal Frontage.
- Surface parking shall be screened from view along secondary frontages.

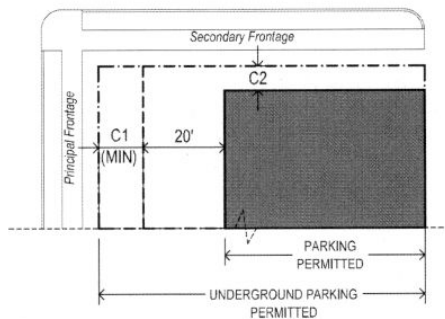

# BROOKHAVEN CODE

## RONKONKOMA HUB TOD

## TABLE 1B. SUBDISTRICT B REQUIREMENTS

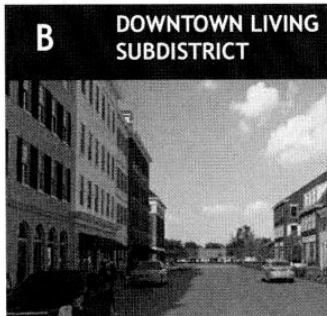

The Downtown Living subdistrict is predominantly a mixed-use residential area with medium to high density building types. It allows for up to 50% commercial use.

### A. USE (see also Table 1)

Residential	Permitted at all levels.
Commercial	Permitted at all levels.
	First floor area for commercial uses in each block is limited to 50% of the linear principal frontage for the block; total area for commercial uses on all floors in a block is limited to 50% of the buildable square footage for the block.

### B. BUILDING CONFIGURATION

B1. Maximum height, feet	Varies. See regulating plan
B2. Max. height, stories	Varies. See regulating plan
B3. Minimum height, stories	2 stories

### C. ALIGNMENT - PRINCIPAL BUILDINGS

C1. Principal Frontage BTZ	2 ft. min. 6 ft. max.
C2. Secondary Frontage BTZ	2 ft. min. 6 ft. max.
C3. Setback from TOD District boundary	25 ft. min.
C4. Build-to frontage	80% min. at build-to-zone.

### D. ACCESSORY BUILDINGS

(NOT USED)

### E. PARKING REQUIREMENTS

See Table 5

### F. STREETScape

Street trees	30' o.c. average
Furnishings	100' o.c. average

### BUILDING CONFIGURATION

- Height (B1) is measured from average grade to top of parapet or top of ridge.
- The number of stories (B2) shall be measured from the average grade and shall exclude attics, basements, and other areas below the average grade.
- A tower, cupola, or other vertical element shall be permitted above the allowed maximum height, but shall not exceed 20% of the first floor area in size, or 20% of the first floor frontage in length.
- Mechanical / utility structures and enclosures are permitted above the allowed height, but must be set back at least 10' from the roof perimeter.
- Except at porches and canopies, or where concealed by a parapet, pitched (shingle) roofs must have an 6:12 or greater slope.
- For buildings taller than three stories, the building design shall have a distinct two- or three-part vertical composition.

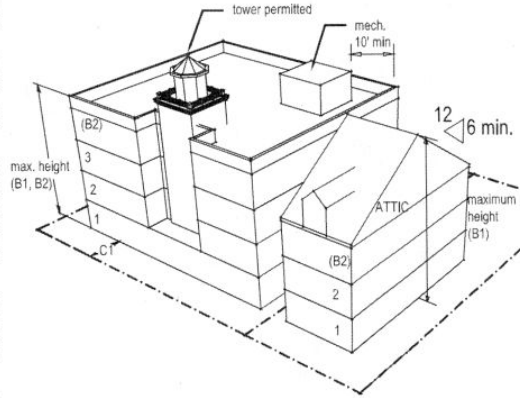

### ALIGNMENT

- Ground floor façades of principal buildings shall be built within the frontage build-to zones (C1, C2) to the minimum specified width (C4).

Exception: Where there is a designated outdoor space between the street lot line and a building, the build-to zone for such building shall be measured from the inner line (i.e. the line opposite and farthest from the lot line) of such designated outdoor space.

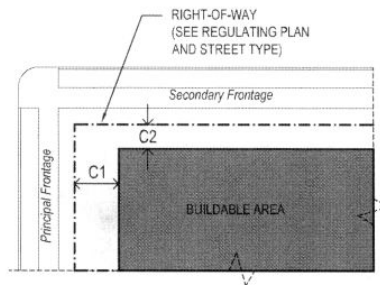

### PARKING PLACEMENT

- Covered and/or surface parking spaces may only be provided where shown in the diagram at right.
- Underground parking is permitted anywhere within the buildable lot area.
- Garage entries from the Principal Frontage must serve a minimum of 8 parking spaces. Entrances to individual one- and two-car garages are not permitted on the Principal Frontage.
- Surface parking shall be screened from view along secondary frontages.

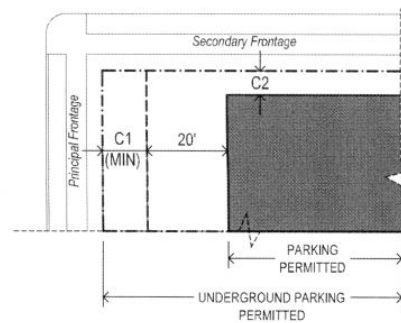

# ZONING

## TABLE 1C. SUBDISTRICT C REQUIREMENTS

## RONKONKOMA HUB TOD

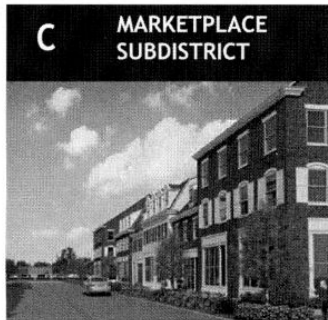

The Marketplace subdistrict allows for predominantly retail-focused mixed-use, maintaining a high level of flexibility to attract diverse local and national retailers.

### C MARKETPLACE SUBDISTRICT

#### BUILDING CONFIGURATION

1. Height (B1) is measured from average grade to top of parapet or top of ridge.
2. The number of stories (B2) shall be measured from the average grade and shall exclude attics, basements, and other areas below the average grade.

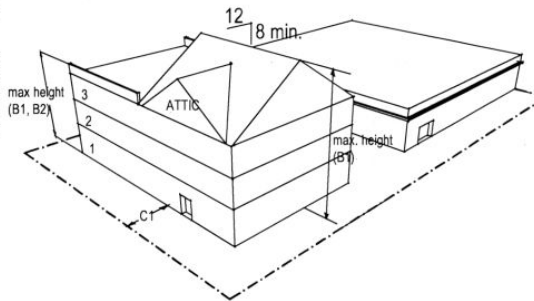

#### ALIGNMENT

1. Ground floor façades of principal buildings shall be built within the frontage build-to zones (C1, C2) to the minimum specified width (C4).

*Exception: Where there is a designated outdoor space between the street lot line and a building, the build-to zone for such building shall be measured from the inner line (i.e. the line opposite and farthest from the lot line) of such designated outdoor space.*

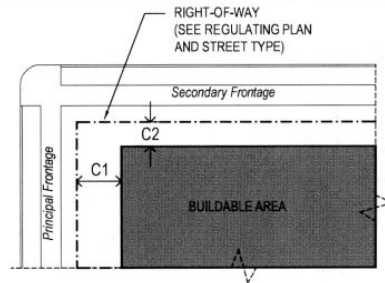

#### A. USE (see also Table 1)

Residential	Permitted. The area for residential uses in each block is limited to 50% of the buildable square footage for the block.
Commercial	Permitted.

#### B. BUILDING CONFIGURATION

B1. Maximum height, feet	56
B2. Max. height, stories	3
B3. Minimum height, feet	24

#### C. ALIGNMENT - PRINCIPAL BUILDINGS

C1. Principal Frontage BTZ	2 ft. min, 6 ft. max.
C2. Secondary Frontage BTZ	2 ft. min, no maximum.
C3. Setback from TOD District boundary	Not Applicable.
C4. Build-to frontage	65% min. at build-to-zone.

#### D. ACCESSORY BUILDINGS (NOT USED)

#### E. PARKING REQUIREMENTS

See Table 5

#### F. STREETScape

Street trees	50 ft o.c. average
Furnishings	50 ft o.c. average

#### PARKING PLACEMENT

1. Covered and/or surface parking spaces may only be provided where shown in the diagram at right.
2. Underground parking is permitted anywhere within the buildable lot area.
3. Garage entries from the Principal Frontage must serve a minimum of 8 parking spaces. Entrances to individual one- and two-car garages are not permitted on the Principal Frontage.
4. Surface parking shall be screened from view along secondary frontages.

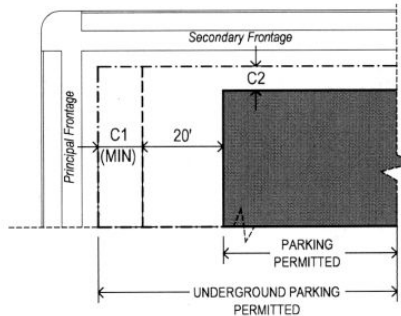

# BROOKHAVEN CODE

## RONKONKOMA HUB TOD

## TABLE 1D. SUBDISTRICT D REQUIREMENTS

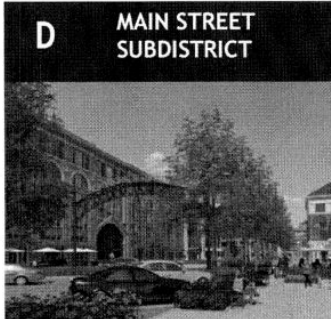

### D MAIN STREET SUBDISTRICT

The Main Street subdistrict is intended as predominantly a pedestrian-oriented, mixed-use town center. Regional shopping, entertainment, and outdoor dining uses are encouraged.

#### A. USE (see also Table 1)

Residential	Residential units are permitted above first floor. Residential common areas are permitted at first floor. <i>Exception: Residential uses are not permitted on parcels located south of Railroad Avenue and west of the intersection of Railroad Avenue and Mill Road.</i>
Commercial	Permitted.

#### B. BUILDING CONFIGURATION

B1. Maximum height, feet	Varies. See regulating plan.
B2. Max. height, stories	Varies. See regulating plan.
B3. Minimum height, stories	3

#### C. ALIGNMENT - PRINCIPAL BUILDINGS

C1. Principal Frontage BTZ	2 ft. min. 4 ft. max.
C2. Secondary Frontage BTZ	2 ft. min. 4 ft. max.
C3. Setback from TOD District boundary	Not Applicable
C4. Build-to frontage	80% min. at build-to zone

#### D. ACCESSORY BUILDINGS (NOT USED)

#### E. PARKING REQUIREMENTS

See Table 5
-------------

#### F. STREETScape

Street trees	50 ft o.c., average
Furnishings	50 ft o.c., average

© Niles Bolton Associates

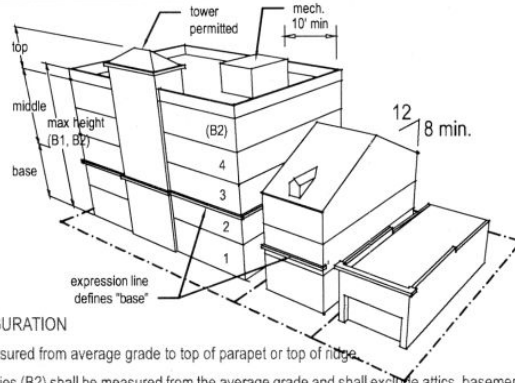

#### BUILDING CONFIGURATION

- Height (B1) is measured from average grade to top of parapet or top of ridge.
- The number of stories (B2) shall be measured from the average grade and shall exclude attics, basements, and other areas below the average grade.
- Mechanical / utility structures and enclosures are permitted above the allowed height, but must be set back at least 10' from the roof perimeter.
- A tower, cupola, or other vertical element shall be permitted above the allowed maximum height, but shall not exceed 20% of the first floor area in size, or 20% of the first floor frontage in length.
- Pitched (shingle) roofs, where not concealed by a parapet, must have an 8:12 or greater slope.
- For buildings taller than one story, a horizontal expression line is required at the second or third floor line, or between the second and third floor lines.
- For buildings taller than three stories, the building design shall have a distinct three-part vertical composition consisting of a base, middle, and top.

#### ALIGNMENT

- Ground floor façades of principal buildings shall be built within the frontage build-to zones (C1, C2) to the minimum specified width (C4).

*Exception: Where there is a designated outdoor space between the street lot line and a building, the build-to zone for such building shall be measured from the inner line (i.e. the line opposite and farthest from the lot line) of such designated outdoor space.*

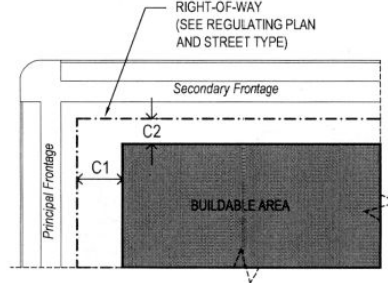

#### PARKING PLACEMENT

- Covered and/or surface parking spaces may only be provided where shown in the diagram at right.
- Underground parking is permitted anywhere within the buildable lot area.
- Garage entries from the Principal Frontage must serve a minimum of 8 parking spaces. Entrances to individual one- and two-car garages are not permitted on the Principal Frontage.
- Surface parking shall be screened from view along secondary frontages.

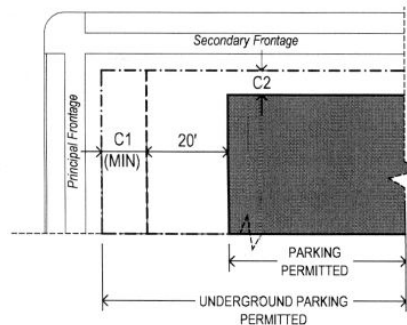

# ZONING

## TABLE 2. USES

## RONKONKOMA HUB TOD

**TABLE 2: Permitted uses.** Any building or land in the Ronkonkoma Hub TOD District may include a combination of the uses permitted below.

### **A. Permitted uses**

- 1) Farmers' Market
- 2) Live/Work Units
- 3) Parking Garages
- 4) All residential and commercial uses, accessory uses and special permit uses authorized in Chapter 85 shall be permitted except as listed in Table 2, Section B.

### **B. Prohibited uses**

- 1) All uses exclusively permitted and/or exclusively special permitted in L-Industrial-1 and L-Industrial-2, L-Industrial-4, K Business, MHC-Mobile Home Community, HF-Horse Farm and PC- Pet Cemetery districts shall be prohibited.
- 2) Outdoor storage, boat storage, motor vehicle repair, heavy construction vehicle dealerships, kennels, lumberyards and/or trucking terminals shall be prohibited.

BROOKHAVEN CODE

RONKONKOMA HUB TOD

TABLE 3. PUBLIC STREET TYPES

**TABLE 3: Public street type designs.** These street types may be used for public or private rights-of-way as approved during the detailed site plan process. Streets shall generally be design for 30 miles per hour vehicular traffic. Specific street and roadway designs may vary from the following standard forms to accommodate required traffic mitigation measures (e.g., additional turning lanes). \*Final lane widths as determined by the Planning Board.

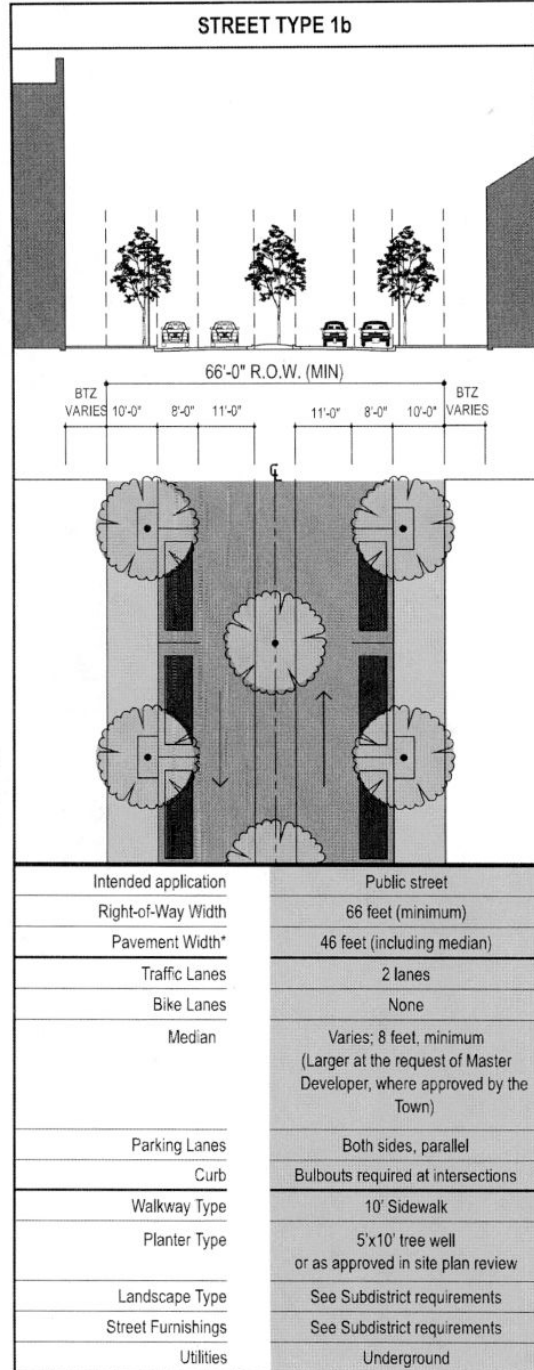
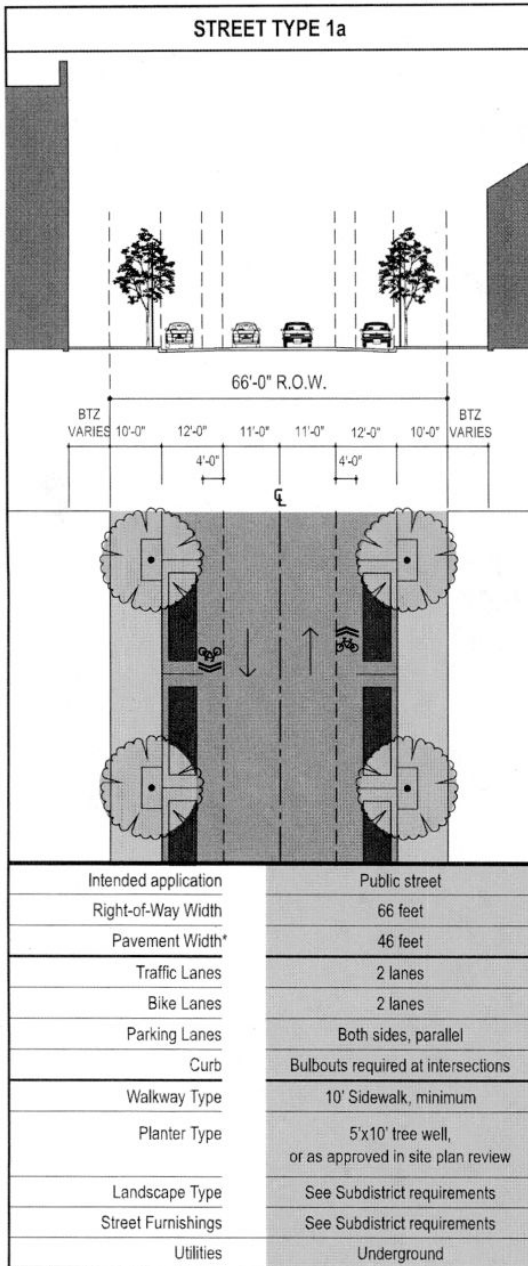

ZONING

TABLE 3.(CONT'D) PUBLIC STREET TYPES

RONKONKOMA HUB TOD

TABLE 3: Public street type designs. (Continued)

STREET TYPE 1c		STREET TYPE 2	
<p>54'-0" R.O.W.</p> <p>BTZ VARIES 8'-0" 8'-0" 4'-0" 11'-0" 11'-0" 4'-0" 8'-0" BTZ VARIES</p>		<p>80'-0" R.O.W.</p> <p>BTZ VARIES 10'-0" 19'-0" 11'-0" 11'-0" 19'-0" 10'-0" BTZ VARIES</p>	
Intended application	Public street	Intended application	Public street
Right-of-Way Width	54 feet	Right-of-Way Width	80 feet
Pavement Width*	38 feet	Pavement Width*	60 feet
Traffic Lanes	2 lanes	Traffic Lanes	2 lanes
Bike Lanes	2 lanes	Bike Lanes	None
Parking Lanes	One side, parallel	Parking Lanes	Both sides, angled
Curb	Bulbouts required at intersections	Curb	Bulbouts required at intersections
Walkway Type	8' Sidewalk	Walkway Type	10' Sidewalk
Planter Type	4'x10' tree well	Planter Type	5'x10' tree well
Landscape Type	See Subdistrict requirements	Landscape Type	See Subdistrict requirements
Street Furnishings	See Subdistrict requirements	Street Furnishings	See Subdistrict requirements
Utilities	Underground	Utilities	Underground

BROOKHAVEN CODE

RONKONKOMA HUB TOD

TABLE 3. (CONT'D) PUBLIC STREET TYPES

TABLE 3: Public street Type designs. (Continued.)

STREET TYPE 4	
Intended application	Public street
Right-of-Way Width	50 feet
Pavement Width*	22 feet
Traffic Lanes	2 lanes
Bike Lanes	None
Parking Lanes	None
Curb Radius	(undefined)
Walkway Type	5' Sidewalk (minimum)
Planter Type	5' wide planting strip or 5'x10' tree well
Landscape Type	See subdistrict requirements: <i>Exception: at this Street Type, tree requirements must be met on only one side of street</i>
Street Furnishings	See Subdistrict requirements
Utilities	Underground

ZONING

**TABLE 4. PRIVATE STREET TYPES**

**RONKONKOMA HUB TOD**

**TABLE 4: Private street type designs.** These street types, in addition to the Public Street Types in Table 3, are permitted by right as private street types within the Ronkonkoma Hub TOD District. Private street cartways and sidewalks shall be open to vehicular and pedestrian use by the general public. These shall not be interpreted to limit other configurations of streets, drives, and parking aisles, as approved in detailed site plan review. Specific street and roadway designs may vary from the following standard forms to accommodate required traffic mitigation measures (e.g. additional turning

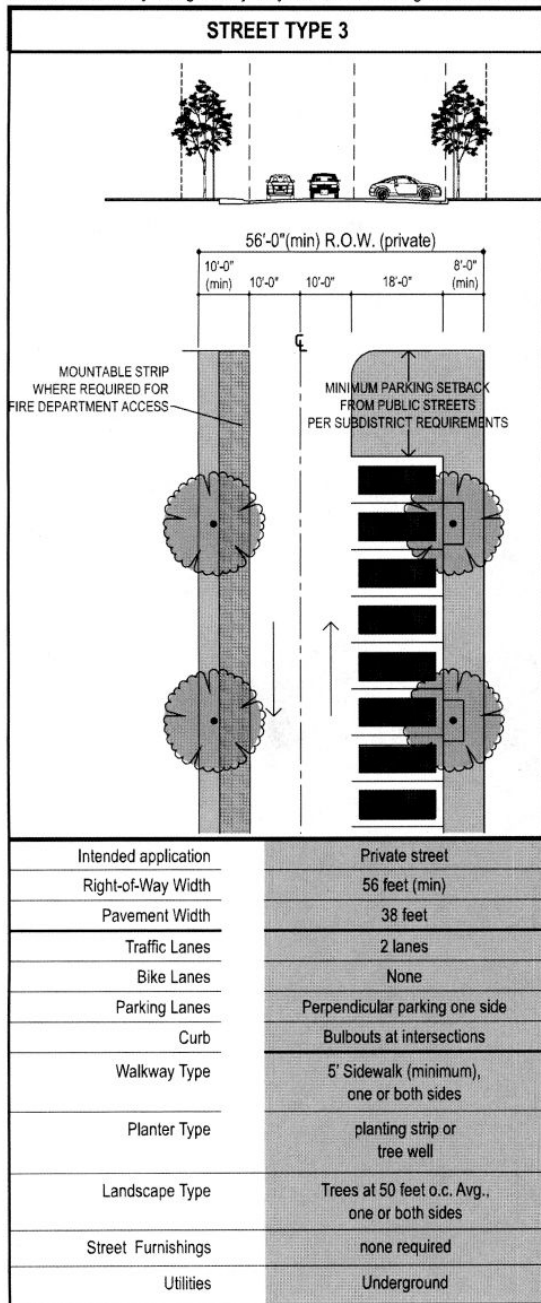

BROOKHAVEN CODE

RONKONKOMA HUB TOD

TABLE 5. PARKING REQUIREMENTS

TABLE 5: Parking requirements. Except as noted, the provisions in this table shall be the exclusive parking provisions for the Ronkonkoma Hub TOD District, and shall supersede and prevail over other parking provisions in the Town Code.

Land Use	Minimum parking spaces required
a. Residential	1.20 spaces per dwelling unit
b. Commercial	2.65 spaces per 1,000 square feet of building area
c. Restaurant	0.33 spaces per seat
d. Office	2.86 spaces per 1,000 square feet of building area

Parameter	Requirement
e. Size of parking space	Minimum 9 ft x 18 ft
f. Drive aisle width (double-loaded)	Minimum 24 ft
g. Drive aisle width (single-loaded)	Minimum 20 ft
h. Landscape screening	Required for surface parking abutting primary and secondary frontage
i. Unbuffered garage exposure at principal frontage	Maximum 16 ft interruption of frontage. <i>Exception: Maximum 40 ft. interruption of frontage at vehicular entrance. (see illustration below)</i>

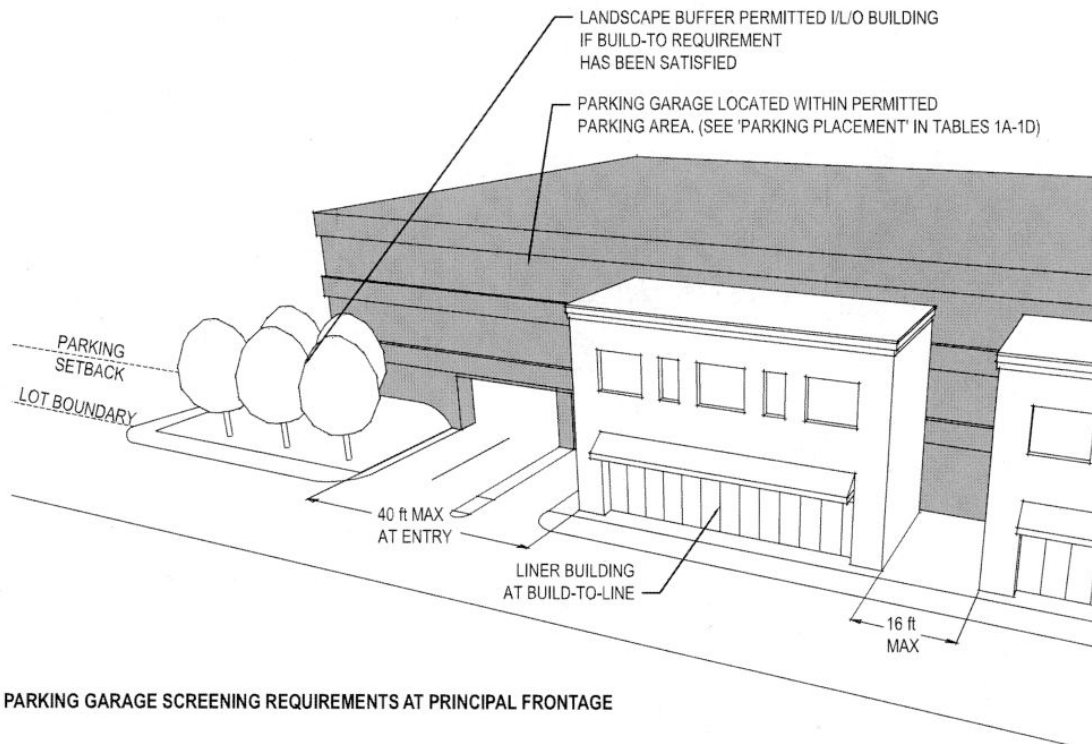

# ZONING

**TABLE 6. DESIGNATED OUTDOOR SPACE**

RONKONKOMA HUB TOD

**TABLE 6a: Designated Outdoor Space.** The provisions in this table shall be the exclusive provisions for open space in the Ronkonkoma Hub TOD District, and shall supersede and prevail over any other open space provisions in the Town Code. For each site plan application in the Ronkonkoma Hub TOD District, designated outdoor space shall be provided, as necessary, to ensure that such space, combined with the area of the existing train station plaza and the areas of designated outdoor space provided on all previously-approved site plans in the Ronkonkoma Hub TOD District, does not, at any time, constitute less than 5% of the total buildable lot area covered by the proposed site plan application and all previously-approved site plans in the Ronkonkoma Hub TOD District.

Shade structures, including but not limited to umbrellas, awnings, tensile fabric structures, and brise-soleil shall be permitted in any designated outdoor space.

**TABLE 6b: Designated Outdoor Space Types.** This table defines types of Designated Outdoor Space which meet the Designated Outdoor Space requirement and the subdistricts in which each Type is permitted

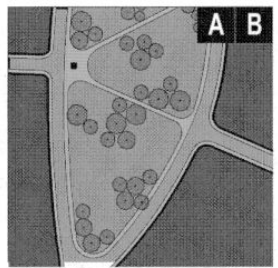
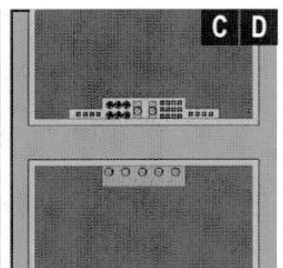
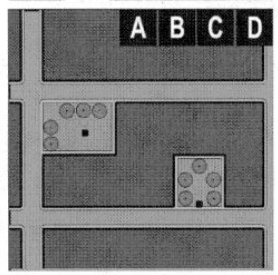
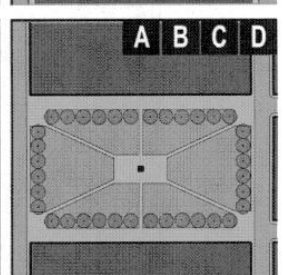
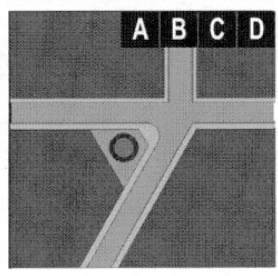
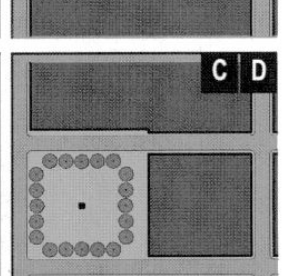
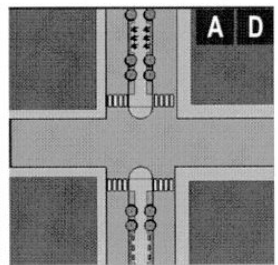

<p><b>a. Green:</b> An informal outdoor space, available for unstructured recreation. A green may be spatially defined by landscaping rather than building facades. Its landscape shall consist of lawn and trees, naturalistically disposed. The minimum size shall be 1/8 acre.</p>	 <p style="text-align: right;"><b>A B</b></p>	<p><b>e. Outdoor Activity Zone:</b> An outdoor space available for civic or commercial use in which an enlarged sidewalk or landscape area is provided in excess of the minimum required by at least four feet in width. Outdoor dining areas, even where restricted to use by patrons of a specific establishment, qualify as an outdoor activity zone.</p>	 <p style="text-align: right;"><b>C D</b></p>
<p><b>b. Pocket Park:</b> A small outdoor space located within a block or interspersed among blocks. A pocket park may include a playground. Where bounded by landscape walls or formal hedges, a pocket park may be counted toward required buildout at frontage. The minimum size shall be 800 sf.</p>	 <p style="text-align: right;"><b>A B C D</b></p>	<p><b>f. Square:</b> A formal outdoor space available for unstructured recreation and civic purposes. A square is spatially defined by building facades. Its landscape shall consist of paths, lawns and trees, formally disposed. The minimum size shall be 5000 sf. A square may be counted toward required buildout at frontage.</p>	 <p style="text-align: right;"><b>A B C D</b></p>
<p><b>c. Node:</b> A small formal outdoor space at or within prominent intersections. A node may include art installations, fountains, or structured planters.</p>	 <p style="text-align: right;"><b>A B C D</b></p>	<p><b>g. Plaza:</b> A formal outdoor space available for civic purposes and commercial activities. A plaza shall be spatially defined by building facades. Its landscape shall consist primarily of pavement. Trees are optional. The minimum size shall be 5000 sf. A plaza may be bisected by a street if the pavement and curb profile distinguish the street as part of the plaza area. A plaza may be counted toward required buildout at frontage.</p>	 <p style="text-align: right;"><b>C D</b></p>
<p><b>d. Median:</b> A small outdoor space located within a street right-of-way, separating vehicular travel lanes with either landscape or hardscape. A median must be a minimum of ten feet in width, and include a usable amenity such as seating or bicycle parking to qualify as designated outdoor space.</p>	 <p style="text-align: right;"><b>A D</b></p>		

# BROOKHAVEN CODE

## RONKONKOMA HUB TOD

## TABLE 7: SIGNS

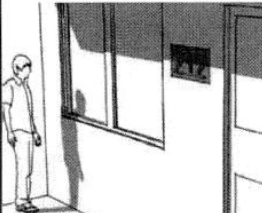
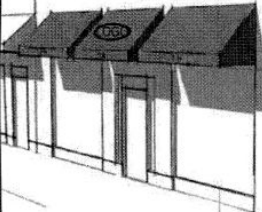
**TABLE 7: Permitted signs.** In addition to all other signs permitted by the Town Code, the specific signage types identified herein are permitted in the indicated subdistricts of the Ronkonkoma Hub TOD District, provided they meet the specifications set forth herein. The signage specifications set forth herein prevail over and supersede any provisions of the Town Code that otherwise prohibit or restrict the signage types set forth herein.

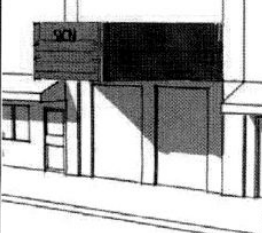



Subdistrict	A	B	C	D	SPECIFICATIONS
<b>Address or Nameplate Sign</b> 	■	■	■	■	Quantity (max) _____ 1 per address Area _____ max 2 sf Width _____ max 24 in Height _____ max 24 in Depth / Projection _____ max 3 in Max mounting height (top) _____ 7 ft Letter Height _____ max 6" Illumination _____ max 185 lumens internal
<b>Awning with Sign</b> 	■	■	■	■	Quantity (max) _____ 1 per window/door Area _____ n/a Width _____ max equals width of Facade Height _____ n/a Depth / Projection _____ min 3 ft, max 6 ft Clearance _____ min 8 ft Max mounting height (top) _____ first floor only Letter Height _____ min 5 in, max 10 in Logo _____ one per business Valance Height _____ max 12 in Distance from Curb _____ min. 2 ft. Illumination _____ External, building-mounted only. Permitted surface materials _____ Fabric, metal roofing, glass. Encroachment into ROW _____ 3 ft permitted
<b>Band Sign</b> 	■	■	■	■	Quantity (max) _____ 1 per 24 ft of facade length Area (max) _____ 2 sf per linear ft Facade Width _____ max 90% width of Facade Height (Subdistrict B) _____ max 18 in Height (Subdistrict C,D) _____ max 3 ft Depth / Projection _____ max 7 in Clearance _____ min 7 ft Letter Height _____ max 24 in Illumination _____ External, building-mounted only.
<b>Shingle Sign</b> 	■	■	■	■	Quantity _____ max 1 per business; max 1 per 24 lf of facade Area (Subdistrict A) _____ max 6 sf Area (Subdistrict B,C,D) _____ max 4 sf Width _____ max 4 ft Height _____ max 4 ft Depth / Projection _____ max 4 ft Clearance _____ min 8 ft Max mounting height (top) _____ n/a Letter Height _____ max 8 in Encroachment into ROW _____ 3 ft permitted
<b>Marquee and Sign</b> 	■	■	■	■	Quantity (max) _____ 1 per block Area _____ n/a Width (max) _____ entrance plus 2' each side Height _____ max 50% Story height Depth / Projection _____ min 4 ft, max 10 ft Clearance _____ min 10 ft Max mounting height (top) _____ n/a Letter Height _____ n/a Distance from Curb _____ min 3 ft.

ZONING

TABLE 7: SIGNS (CONT'D)

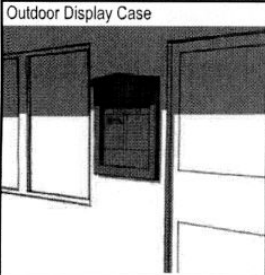
RONKONKOMA HUB TOD

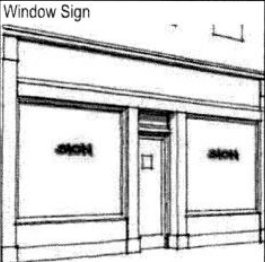
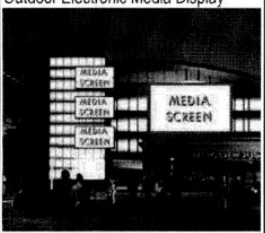
TABLE 7: Permitted signs. (continued)

Subdistrict	A	B	C	D	Specifications
<p>Outdoor Display Case</p> 		■	■	■	<p>Quantity _____ 1 per entrance</p> <p>Area _____ max 6 sf</p> <p>Width _____ max 3.5 ft</p> <p>Height _____ max 3.5 ft</p> <p>Depth / Projection _____ max 5 in</p> <p>Clearance _____ min 4 ft</p> <p>Max.mounting height (top) _____ 8 ft</p> <p>Illumination _____ max 2000 lumens internal</p>
<p>Sidewalk Sign</p> 		■	■	■	<p>Quantity _____ 1 per retail or food service business</p> <p>Area _____ max 8 sf</p> <p>Width _____ max 26 in</p> <p>Height _____ max 42 in</p>
<p>Window Sign</p> 		■	■	■	<p>Quantity _____ 1 per window</p> <p>Area _____ max 25% of glass</p> <p>Clearance _____ 4 ft</p> <p>Letter Height _____ max 12 in</p>
<p>Outdoor Electronic Media Display</p> 				■	<p><b>LARGE</b></p> <p>Quantity _____ 1 maximum in TOD</p> <p>Area _____ max 920 sf</p> <p>Width _____ max 40 ft</p> <p>Height _____ max 23 ft</p> <p>Max.mounting height (top) _____ max 42 ft</p> <p><b>SMALL</b></p> <p>Quantity _____ 3 maximum in TOD</p> <p>Area _____ max 144 sf</p> <p>Width _____ max 16 ft</p> <p>Height _____ max 9 ft</p> <p>Max.mounting height (top) _____ max 42 ft</p>
<p>Neon</p> 				■	<p>Custom-made only</p> <p>Area _____ max 144 sf</p> <p>Max.mounting height (top) _____ max 42 ft</p>

BROOKHAVEN CODE

RONKONKOMA HUB TOD

TABLE 7: SIGNS (CONT'D)

TABLE 7: Permitted signs. (continued)

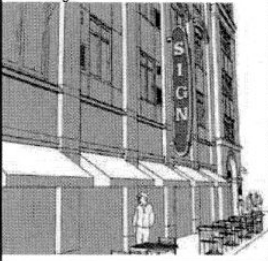
Subdistrict	A	B	C	D	Specifications																
<p>Blade Sign</p> 			■	■	<table border="1"> <tr> <td>Quantity</td> <td>1 per 40 ft of frontage</td> </tr> <tr> <td>Width</td> <td>max 30 in</td> </tr> <tr> <td>Vertical length</td> <td>max 50% of facade height</td> </tr> <tr> <td>Depth</td> <td>max 8 in</td> </tr> <tr> <td>Clearance</td> <td>min 8 ft</td> </tr> <tr> <td>Max. mounting height (top)</td> <td>35 ft</td> </tr> <tr> <td>Illumination</td> <td>unrestricted</td> </tr> <tr> <td>Encroachment into R.O.W.</td> <td>2' permitted</td> </tr> </table>	Quantity	1 per 40 ft of frontage	Width	max 30 in	Vertical length	max 50% of facade height	Depth	max 8 in	Clearance	min 8 ft	Max. mounting height (top)	35 ft	Illumination	unrestricted	Encroachment into R.O.W.	2' permitted
Quantity	1 per 40 ft of frontage																				
Width	max 30 in																				
Vertical length	max 50% of facade height																				
Depth	max 8 in																				
Clearance	min 8 ft																				
Max. mounting height (top)	35 ft																				
Illumination	unrestricted																				
Encroachment into R.O.W.	2' permitted																				

## ZONING

**TABLE 8. SUPPLEMENTARY PUBLIC LIGHTING**

RONKONKOMA HUB TOD

**TABLE 5: Supplementary Public Lighting.** The generic lighting types below shall be permitted in the subdistricts indicated. Except as noted, the provisions in this table shall be the exclusive lighting provisions for the TOD zoning district, and shall supersede and prevail over other lighting provisions in the Town Code. This table shall not prohibit any lighting otherwise permitted in the Town of Brookhaven. (The illustrations do not indicate a specific luminaire, only the general form, proportion, and light distribution)

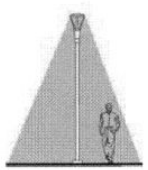
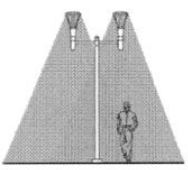
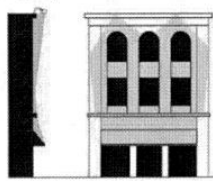
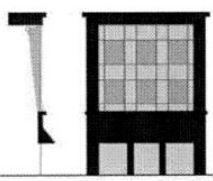
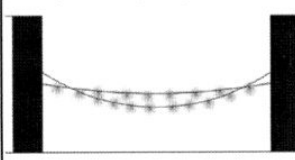

Subdistrict	A	B	C	D	Characteristics
	■	■	■	■	Light source: LED, ceramic metal halide, and others as permitted elsewhere in the Code. Color temperature: Unrestricted Cutoff: fully shielded Spill onto adjacent properties: Permitted to spill within and among the C & D subdistricts. Maximum height: 20 ft
	■	■	■	■	Light source: LED, ceramic metal halide, and others as permitted elsewhere in the Code. Color temperature: Unrestricted Cutoff: fully shielded Spill onto adjacent properties: Permitted to spill within and among the C & D subdistricts. Maximum height: 20 ft
		■	■	■	Light source: LED, ceramic metal halide, and others as permitted elsewhere in the Code. Color temperature: Unrestricted Cutoff: fully shielded Spill onto adjacent properties: Permitted to spill within and among the C & D subdistricts. Maximum height: 20 ft
			■	■	Light source: LED, ceramic metal halide, and others as permitted elsewhere in the Code. Color temperature: Unrestricted Cutoff: partially shielded (fully shielded from public side) Spill onto adjacent properties: Permitted to spill within and among the C & D subdistricts.
				■	Light source: LED, ceramic metal halide, and others as permitted elsewhere in the Code. Color temperature: Unrestricted Cutoff: (Not applicable) Spill onto adjacent properties: Permitted to spill within and among B, C & D subdistricts.
				■	Permitted only where approved by the Town, and subject to establishment of a maintenance agreement between the Town and the Master Developer. Light source: LED, ceramic metal halide, and others as permitted elsewhere in the Code. Maximum lumens / bulb: 850 lm Color temperature: Unrestricted Cutoff: Non-cutoff Spill onto adjacent properties: Permitted to spill within and among B, C & D subdistricts.

BROOKHAVEN CODE

RONKONKOMA HUB TOD

**TABLE 8. SUPPLEMENTARY PUBLIC LIGHTING**

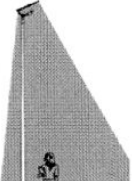
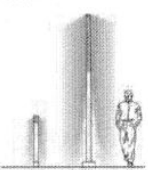
TABLE 5: Supplementary Public Lighting (Continued).

Subdistrict	A	B	C	D	Characteristics
<p>Reflected downlight</p> 				■	<p>Light source: LED, ceramic metal halide, and others as permitted elsewhere in the Code.</p> <p>Color temperature: Unrestricted</p> <p>Cutoff: Indirect cutoff</p> <p>Spill onto adjacent properties: Permitted to spill within and among the C &amp; D subdistricts.</p> <p>Maximum height: 20 ft</p>
<p>Light Column</p> 			■	■	<p>Light source: LED, ceramic metal halide, and others as permitted elsewhere in the Code.</p> <p>Color temperature: Unrestricted</p> <p>Cutoff: Fully shielded</p> <p>Spill onto adjacent properties: Permitted to spill within and among the C &amp; D Subdistricts</p> <p>Maximum height: 12'</p>
<p>Neon</p> 				■	<p>Custom-made only (generic, mass-produced neon signs are prohibited)</p> <p>Light source: Neon</p> <p>Color temperature: Unrestricted</p> <p>Cutoff: Unrestricted</p> <p>Spill onto adjacent properties: Permitted to spill within and among the B, C, &amp; D Subdistricts.</p>