

ZONING

170 Attachment 12

City of Dover

Little Bay Waterfront (LBW) District

[Amended 6-22-2016 by Ord. No. 2016.06.08-010; 10-26-2016 by Ord. No. 2016.10.12-015; 10-13-2021 by Ord. No. 2021.09.08-006]

Permitted Uses

- Accessory dwelling unit
- Assembly hall
- Bank
- Barbershop and beauty shop
- Bed-and-breakfast
- Child-care facility
- Commercial recreation
- Dwelling, three- to four-family [3]
- Dwelling, two-family
- Dwelling, single-family
- Eating and drinking establishment [4]
- Educational institution, postsecondary
- Farm animals for family use, for noncommercial purposes, on lots containing a one- or two-family dwelling [5]
- Marina
- Office
- Personal service establishment
- Public utility [6]
- Retail store
- Water-related education/resource center
- Waterborne passenger transportation facility

Dimensional Regulations [1] [2]

| Lot | |
|---------------------------|-----------|
| Minimum lot size | 10,000 sf |
| Maximum lot coverage | 50% |
| Minimum frontage | 75 ft |
| Principal Building | |
| Front setback | 15 ft |
| Abut a street setback | 15 ft |
| Side setback | 10 ft |
| Rear setback | 15 ft |
| Outbuilding/Accessory Use | |
| Front setback | 15 ft |
| Abut a street setback | 15 ft |
| Side setback | 10 ft |
| Rear setback | 10 ft |
| Height of Building | |
| Principal building | 40 ft max |
| Outbuilding | 40 ft max |

Sign Regulations

| Size | LBW District |
|-----------------------|---|
| Total signs permitted | 1 [per tenancy, and is for lot (excluding development identification signs)] |
| Total area permitted | 1 ft of sign area for each 3 ft of linear business frontage |
| Type | |
| Freestanding | Permitted, provided that the principal building is set back at least 20 ft (max ht 16 ft or 12 sf in area regardless of the number of individual tenants within the building) |
| Projecting | Permitted (max size 8 sf) |
| Wall/awning | Permitted (max size 16 sf; max ht 16 ft or to the bottom of the sills of the first level of windows above the first floor, whichever is lowest) |
| Temporary | Permitted |

Principal Building Placement

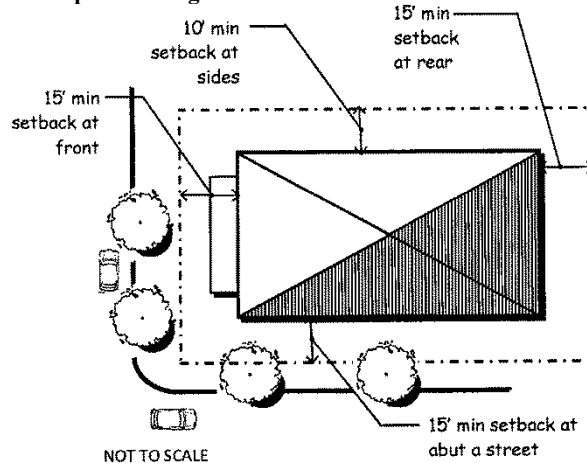

DOVER CODE

Footnotes

- [1] Refer to §§ 170-13, 170-14 and 170-27D for exceptions to lot size, frontage and setback requirements.
- [2] All land containing wetlands shall not be counted in determining the gross land area of a lot for the purposes of minimum lot size or minimum density requirements for residential uses. The minimum nonwetland portion of any newly created lot shall be contiguous. For the purposes of this calculation, wetlands shall include areas that meet the definition of wetland in the New Hampshire Code of Administrative Rules Env-Wt 101.113 and the 1987 Federal Manual for Identifying Jurisdictional Wetlands. Wetland buffers shall only be allowed to count for 40% of the minimum lot size required.
- [3] Provided that the lot contains at least 10,000 square feet per dwelling unit.
- [4] If fully enclosed with no drive-in service.
- [5] Use is allowed on the portion of the lot that is behind the principal structure, provided the following standards are met. Chickens: no more than 6 chickens and no roosters, with 3 square feet of chicken coop and 20 square feet of a fenced enclosure yard per chicken; all coops and enclosures shall be 20 feet from any property line. Sheep or goats: 1 animal per 10,000 square feet of lot area, with a maximum of 6 animals; 10 square feet of shelter and 30 square feet of a fenced enclosure yard per animal; all shelters and enclosures shall be 30 feet from any property line.
- [6] The utility facility shall be appropriately fenced to protect the public. Landscaping materials shall be required to provide a visual screen from any structures and storage within.