

ZONING

170 Attachment 9

City of Dover

Innovative Technology (IT) District

[Added 7-22-2020 by Ord. No. 2020.07.08-007; amended 10-13-2021 by Ord. No. 2021.09.08-006; 9-14-2022 by Ord. No. 2022.08.10-010; 10-8-2025 by Ord. No. 2025.09.24-2]

Permitted Uses [10] [11] [12] [13] [14] [15]

- Adult day care
- Child-care facility
- Computer and data processing
- Eating and drinking establishments [7]
- Establishments for the manufacture, assembly, services and repair of the products listed below and other uses of a similar nature:
 - ◊ Drugs
 - ◊ Office, computing and accounting machines
 - ◊ Radio and television receiving equipment; communication equipment
 - ◊ Electronic components and engineering, laboratory, scientific and research instruments and associated equipment
 - ◊ Measuring and controlling instruments
 - ◊ Optical instruments and lenses
 - ◊ Surgical, medical and dental instruments and supplies
 - ◊ Photographic equipment and supplies
 - ◊ Electrotherapeutic, electro-medical and X-ray apparatus
- Excavation
- Farm [8]
- Laboratories (scientific, medical, chemical) and testing facilities devoted to experimental production, research, product development or similar activity
- Office
- Public utility [9]
- Publishing facility
- Veterinary office, animal hospital or kennel [10]
- Warehousing
- Wholesaling

Sign Regulations

Size	IT District
Total signs permitted	2 [per tenancy, and is for lot (excluding development identification signs)]
Total area permitted	1 sf for each linear foot of business frontage (see § 170-50 for regulations for businesses bordering the Spaulding Turnpike)
Type	
Freestanding	Permitted, provided that the principal building is set back at least 75 ft (max ht 16 ft, max size 100 sf)
Projecting	Not permitted
Wall/awning	Permitted
Temporary	Permitted
Sign Size & Quality	
Total signs permitted (see § 170-50 for multiple frontage exceptions)	2 [per tenancy, and is for lot (excluding development identification SIGNS)]

Dimensional Regulations [1] [2]

Lot	
Minimum lot size [3]	2 acres
Maximum lot coverage [4]	33%
Minimum frontage	200 ft [3]
Principal Building	
Front setback [5]	50 ft
Abut a street setback	50 ft
Side setback	50 ft
Rear setback	50 ft
Outbuilding/Accessory Use*	
Front setback	50 ft
Abut a street setback	50 ft
Side setback	10 ft
Rear setback	10 ft
Height of Building	
Principal building [6]	55 ft max
Outbuilding	55 ft max

* Parking areas shall be set back at least 25 feet from property lines.

DOVER CODE

Uses Permitted by Conditional Use

- Educational institution, post-secondary
- Helicopter take offs and landings
- Personal service establishment
- Self-service storage facility

Principal Building Placement

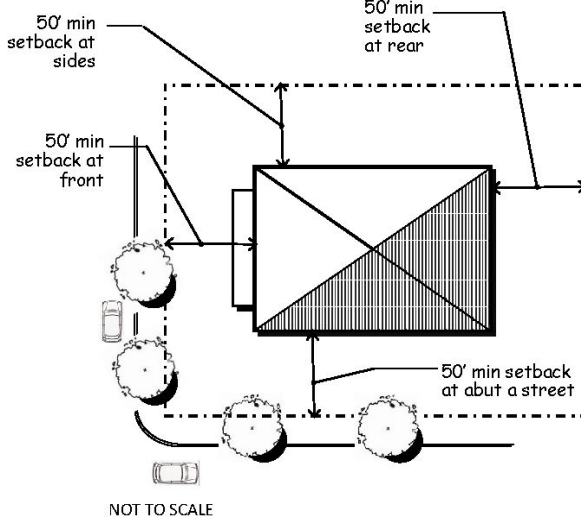

Footnotes

- [1] Refer to §§ 170-13, 170-14 and 170-27D for exceptions to lot size, frontage and setback requirements.
- [2] All land containing wetlands shall not be counted in determining the gross land area of a lot for the purposes of minimum lot size or minimum density requirements for residential uses. The minimum non-wetland portion of any newly created lot shall be contiguous. For the purposes of this calculation, wetlands shall include areas that meet the definition of wetland in the New Hampshire Code of Administrative Rules Env-Wt 101.113 and the 1987 Federal Manual for Identifying Jurisdictional Wetlands. Wetland buffers shall only be allowed to count for 40% of the minimum lot size required.
- [3] Not applicable to lots of internal or private roadways.
- [4] At least 33% of the site shall be maintained as open space, either landscaped or left natural. A maximum of 33% of the site can be covered by buildings.
- [5] See § 170-15.
- [6] The maximum building heights may be increased to 75 feet provided the following conditions are met:
 - A. The additional building height above 50 feet is necessary to meet an industrial function.
 - B. The building is located a minimum of 200 feet from a residential district.

- C. The Planning Board has granted preliminary approval to the development proposal containing the taller building.
- D. The building is for a permitted use, and not one granted by special exception, conditional use permit or variance.
- [7] No drive thru allowed.
- [8] Where farm animals are raised and boarded, shelters to house said animals shall not be less than 100 feet from any property boundary.
- [9] The utility facility shall be appropriately fenced to protect the public. Landscaping materials shall be required to provide a visual screen from any structures and storage within.
- [10] Shelters and runs used to house and/or contain animals shall be no closer than 100 feet to any property line and must support a minimum tract size of 100,000 square feet.
- [11] Parking areas shall be screened from public streets and existing residential uses so as to minimize the visibility of such areas. Screening may consist of vegetation, earth berms, fencing or any combination of the above.
- [12] The allowed activities shall not be obnoxious or offensive by reason of emission of dust, odor, smoke, gas, noise or similar cause. Prior to site plan approval, the applicant shall submit evidence to the Planning Board identifying waste products to be generated by on-site activities. A plan for removal of the waste shall be approved by the Planning Board. Developments that will use, store or generate hazardous chemicals shall identify such chemicals prior to site plan approval. A plan for storage and use of hazardous chemicals shall be approved by the Planning Board. Plans pertaining to waste or hazardous chemicals shall verify compliance with applicable federal, state and local regulations.
- [13] A residential structure located within the Innovative Technology District and existing prior to 7-8-1987 may be increased up to 20% of the gross floor area of habitable space. New dwelling units shall not be allowed. Furthermore, customary accessory structures shall be allowed within the Innovative Technology District, but must remain within 75 feet of the nonconforming residential structure.
- [14] Development within the IT District shall conform to design standards contained in Chapter 153, Site Review Regulations, § 153-15.
- [15] Solar/green roof standard:
 - All buildings shall be constructed to be solar ready ensuring that future installation of solar energy systems can be easily and effectively accommodated.

ZONING

Conditional Use Permit Criteria

The following uses shall be allowed if a conditional use permit is granted by the Planning Board upon a finding that the following criteria are met:

Self-storage facility:

- A. The minimum front setback shall be double the setbacks required in the district.
- B. No storage unit building which units are externally accessed shall be visible from the street.
- C. Hours of operation shall be limited to 9:00 a.m. to 9:00 p.m., Monday through Friday, and 10:00 a.m. to 6:00 p.m. on Saturday and Sunday.
- D. If adjacent to a residential district or a lot containing a residential use, the facility shall:
 - i. Be limited to a one-story structure with a height no more than 20 feet.
 - ii. Not hold auctions or sales of contents of storage containers.
 - iii. Have screening sufficient to block the view of the buildings from abutting parcels and shall prohibit lighting from shedding onto abutting parcels.
- E. All setbacks shall be double the setbacks required in the district, not just the front setback.
- F. The architectural design standards of § 153-14L(8) (b) shall be adhered to.

Helicopter take offs and landings:

- A. There shall be a distance of 1,000 feet between any existing residential structure and any proposed helicopter landing pad.
- B. Except in the case of an emergency, no helicopter take offs or landings shall occur between the hours of 9:00 p.m. and 7:00 a.m.
- C. The facility shall be accessory to the principal use located on the lot.
- D. All facilities shall be located and designed so that the operation thereof will not adversely affect adjacent residential areas, particularly with respect to noise levels.

Educational institution, post-secondary:

- A. The school is a trade/vocational/career technical school.
- B. The school is accredited by the State of New Hampshire

Personal service establishments:

- A. The use is part of a larger retail/office or service center
- B. The use is complimentary to the adjacent advanced manufacturing or assembly uses.