

ZONING

20 Attachment 2

Municipality of Mt. Lebanon

DIAGRAMS

NO SCALE

LOT WIDTH
MEASUREMENT

DIAGRAM 1

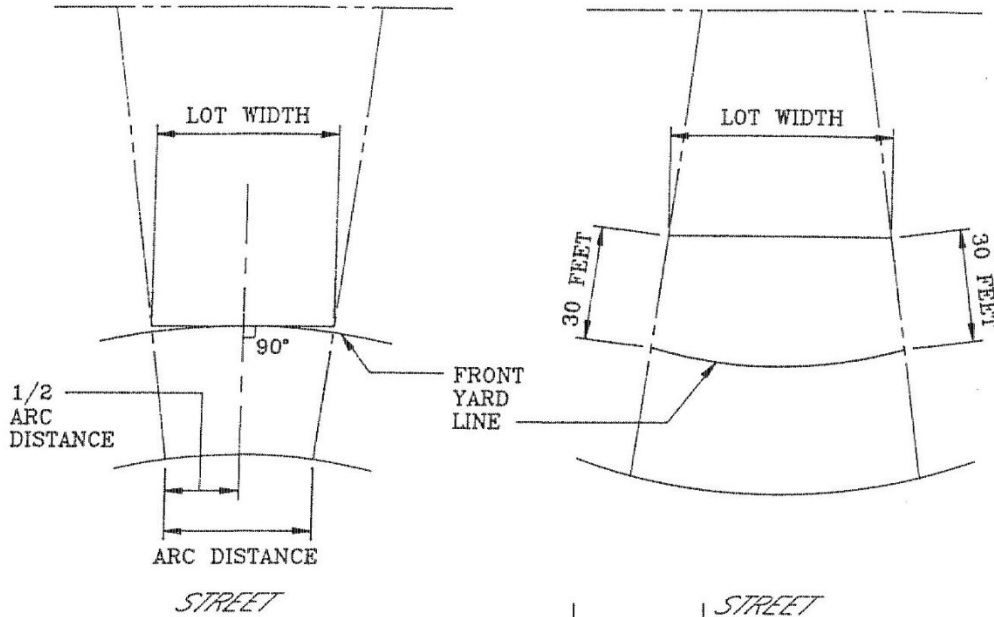

FRONT OR SIDE YARD LINE IN
R-1, R-2, R-3. SIDE YARD
LINE IN ALL OTHER ZONES.

IN R-1, R-2, & R-3 ZONES.
THE LINE ABUTTING EITHER
STREET CAN BE CONSIDERED
THE FRONT LOT LINE. IN ALL
OTHER ZONES, ONLY THE LINE
ABUTTING THE MAJOR STREET
CAN BE CONSIDERED A FRONT
LOT LINE.

FRONT OR SIDE YARD LINE IN
R-1, R-2, R-3. FRONT YARD
LINE IN ALL OTHER ZONES.

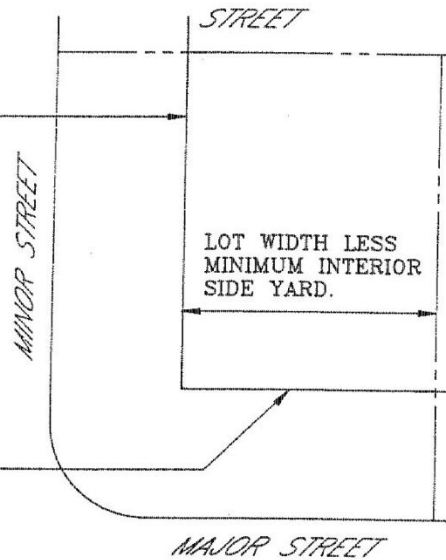

MT. LEBANON CODE

NO SCALE

BUILDING HEIGHT
MEASUREMENT

DIAGRAM 2

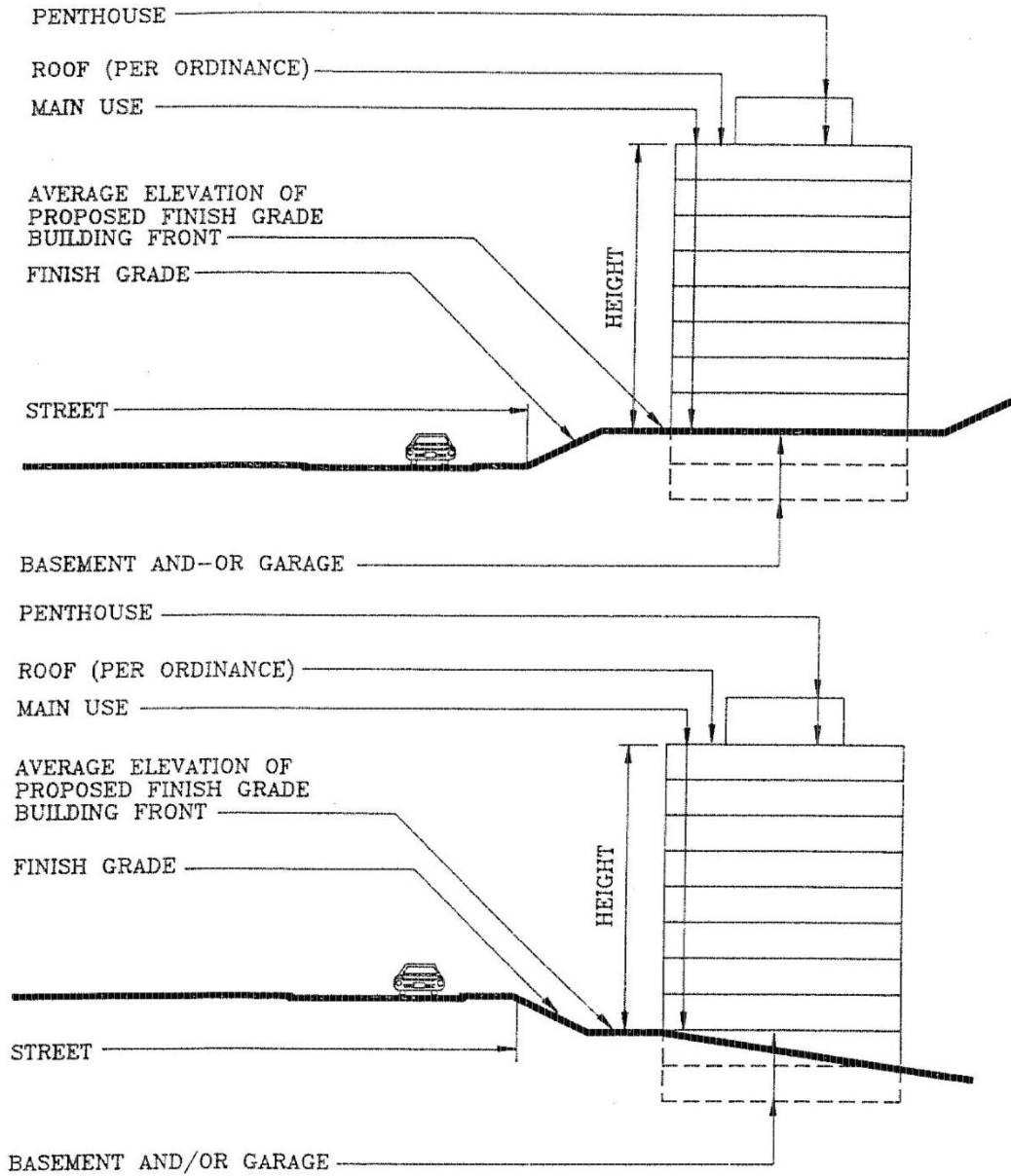

ZONING

NO SCALE

PLAN DEFINING AREA
AND BULK REGULATIONS

DIAGRAM 3

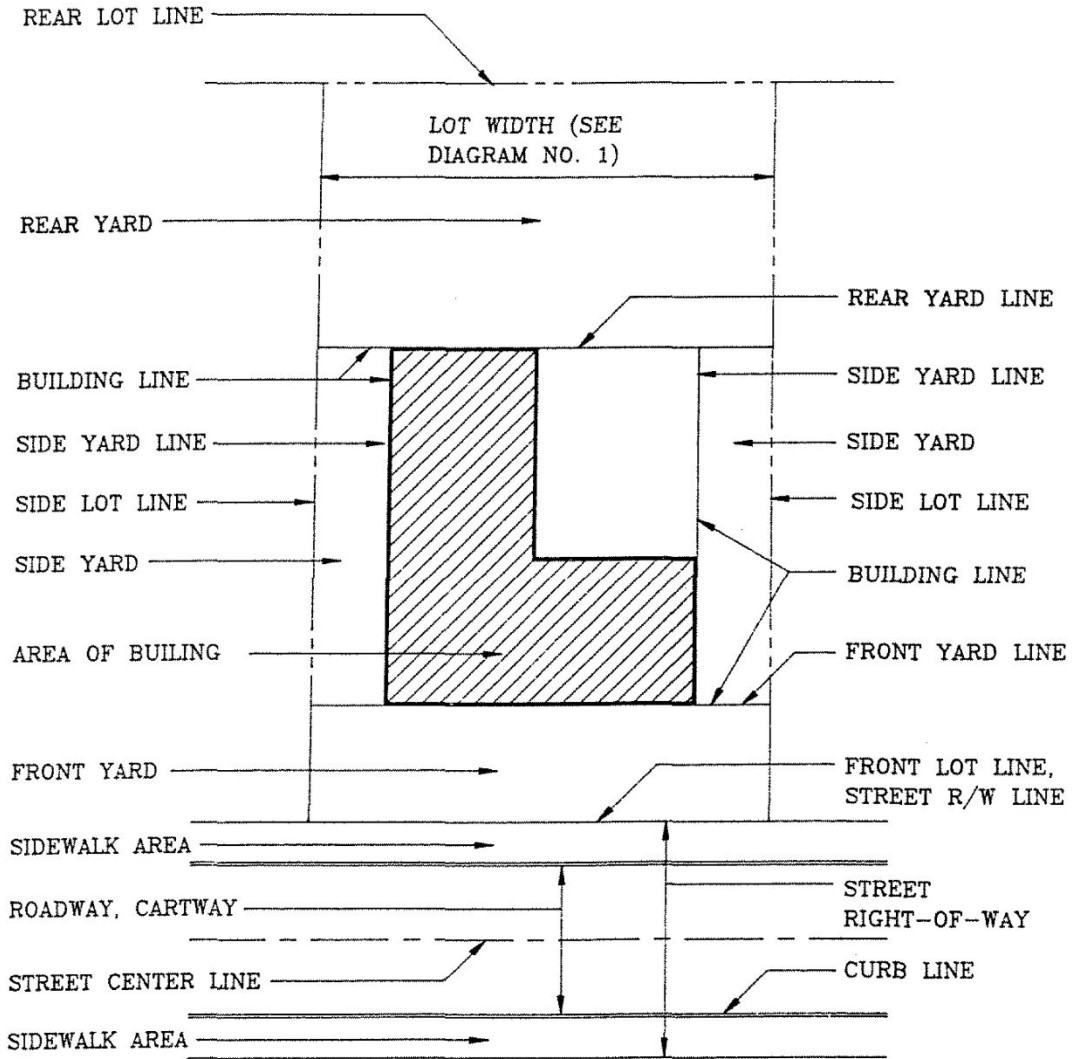

ZONING

NO SCALE

SITE PLAN SYMBOLS AND ABBREVIATIONS

DIAGRAM 5

— — — — —	CENTER LINE
— — — — —	PROPERTY LINE
—————	STREET RIGHT-OF-WAY
<u>BUILDING</u> <u>SETBACK</u>	ZONING SETBACK (IDENTIFY)
— — 90 — —	EXISTING CONTOUR
————— 90	PROPOSED CONTOUR
— — — — —	INDICATES EXISTING CONDITIONS
+ 94.50	SPOT ELEVATION

B.C. 93.70	BOTTOM OF CURB
BS	BOTTOM OF SLOPE
B.W. 94.56	BOTTOM OF WALL
CB	CATCH BASIN
CIP	CAST IRON PIPE
CLF	CHAIN LINK FENCE
CMP	CORRUGATED METAL PIPE
CPP	CORRUGATED PLASTIC PIPE
CO	CLEAN OUT
FT/FT	FEET PER FEET
H	HANDICAPPED PARKING
HP	HIGH POINT
INL. ELEV.	INLET ELEVATION
INV. ELEV.	INVERT ELEVATION
LP	LOW POINT
N.I.C.	NOT IN CONTRACT
MH	MANHOLE
PC	POINT OF CURVATURE
P.V.C.	POINT OF VERTICAL CURVE
PVC	POLYVINYL CHLORIDE
PT	POINT OF TANGENCY
R-60'	RADIUS
RCP	REINFORCED CONCRETE PIPE
R/W	RIGHT-OF-WAY
SI	STORM INLET
T.C. 94.20	TOP OF CURB
TS	TOP OF SLOPE
T.W. 98.00	TOP OF WALL
VC	VERTICAL CURVE
VCP	VITRIFIED CLAY PIPE

MT. LEBANON CODE

NO SCALE

LEGEND
SITE CONSTRUCTION

DIAGRAM 6

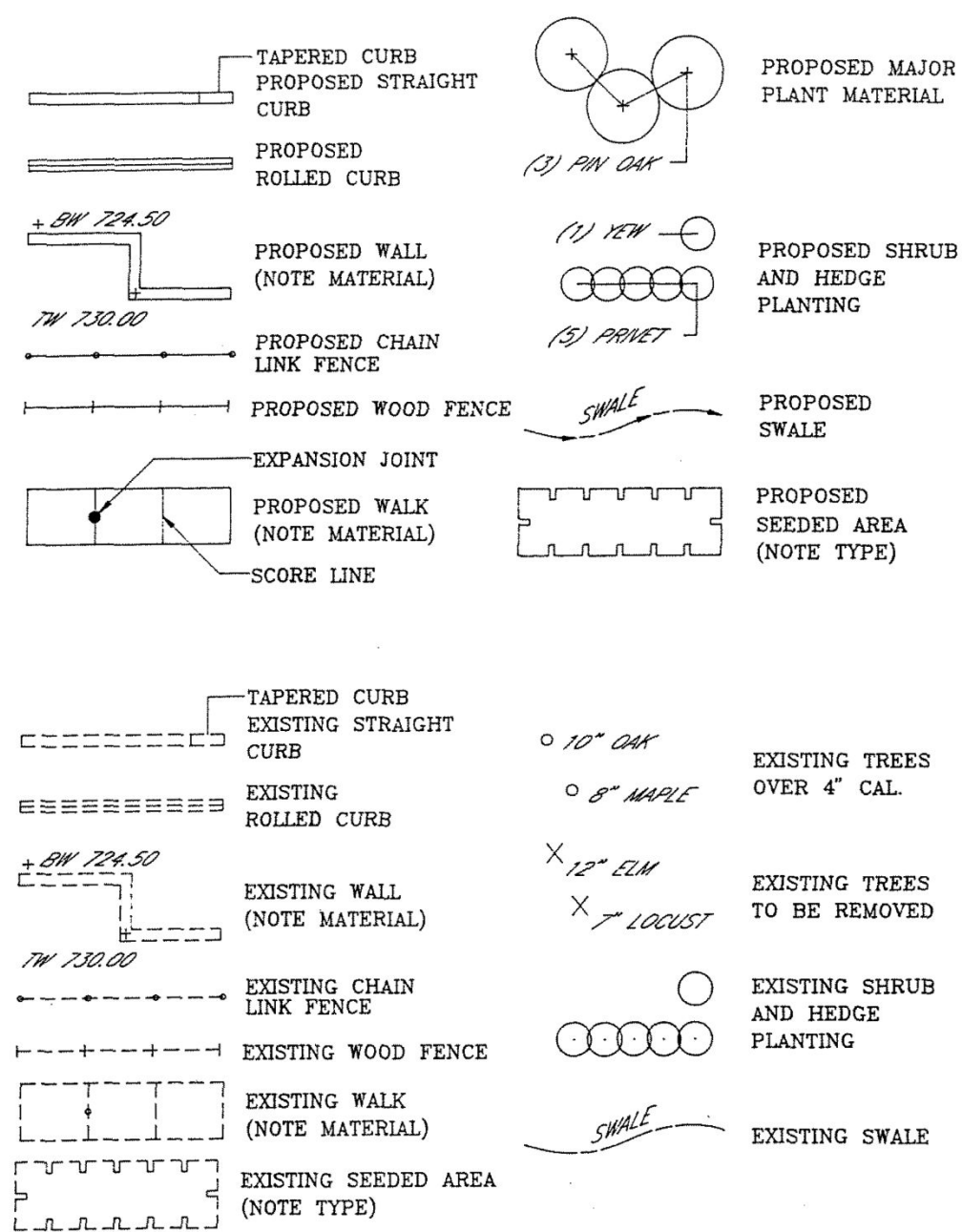

ZONING

NO SCALE

LEGEND SITE UTILITIES

DIAGRAM 7

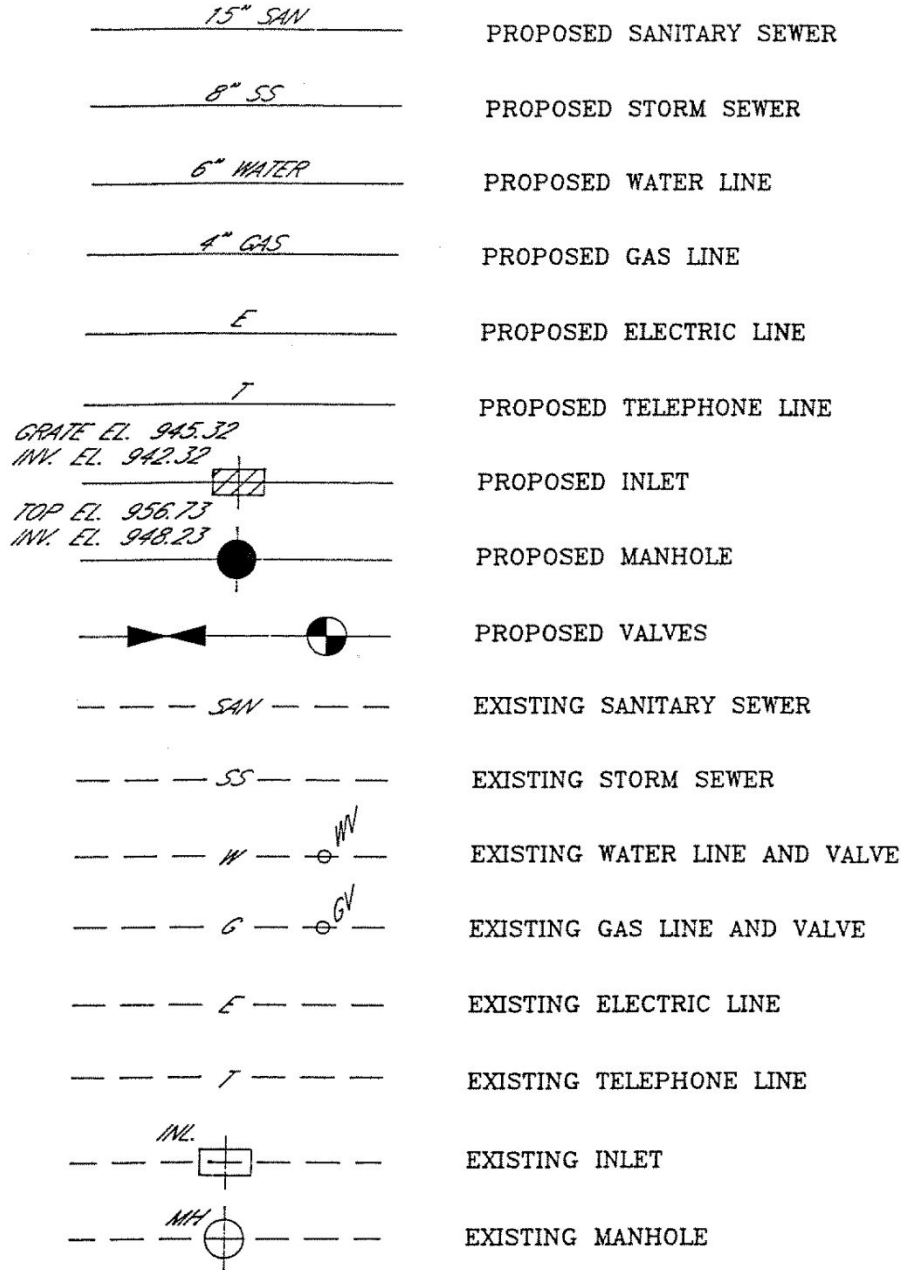

MT. LEBANON CODE

NO SCALE

PARKING AREA LIMITS
C AND C-1 PLANNED MIXED DEVELOPMENT DISTRICTS

DIAGRAM 8

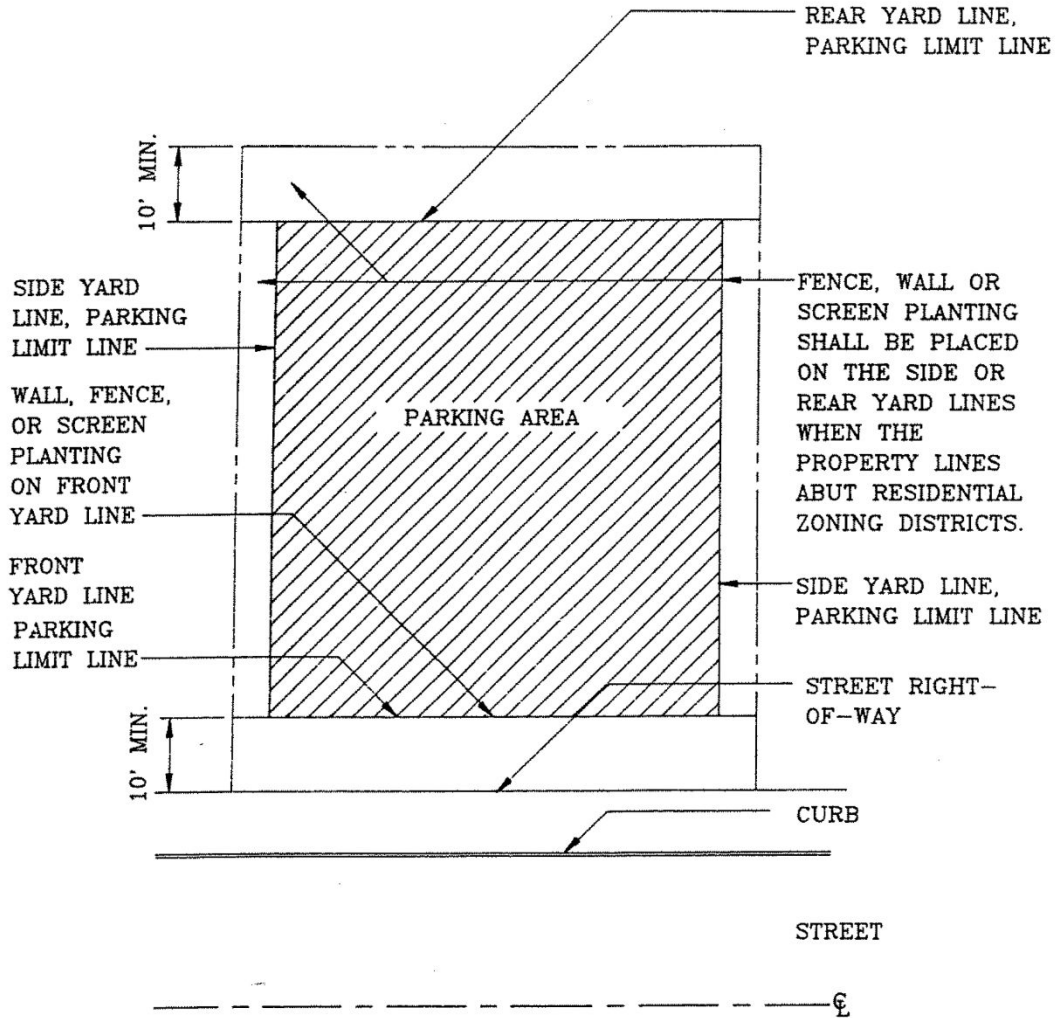

ZONING

NO SCALE

PARKING AREA LIMITS
LS, R-4, R-4A, R-5, R-6, R-7, TRANSITIONAL
AREAS AND PLANNED RESIDENTIAL DEVELOPMENTS

DIAGRAM 9

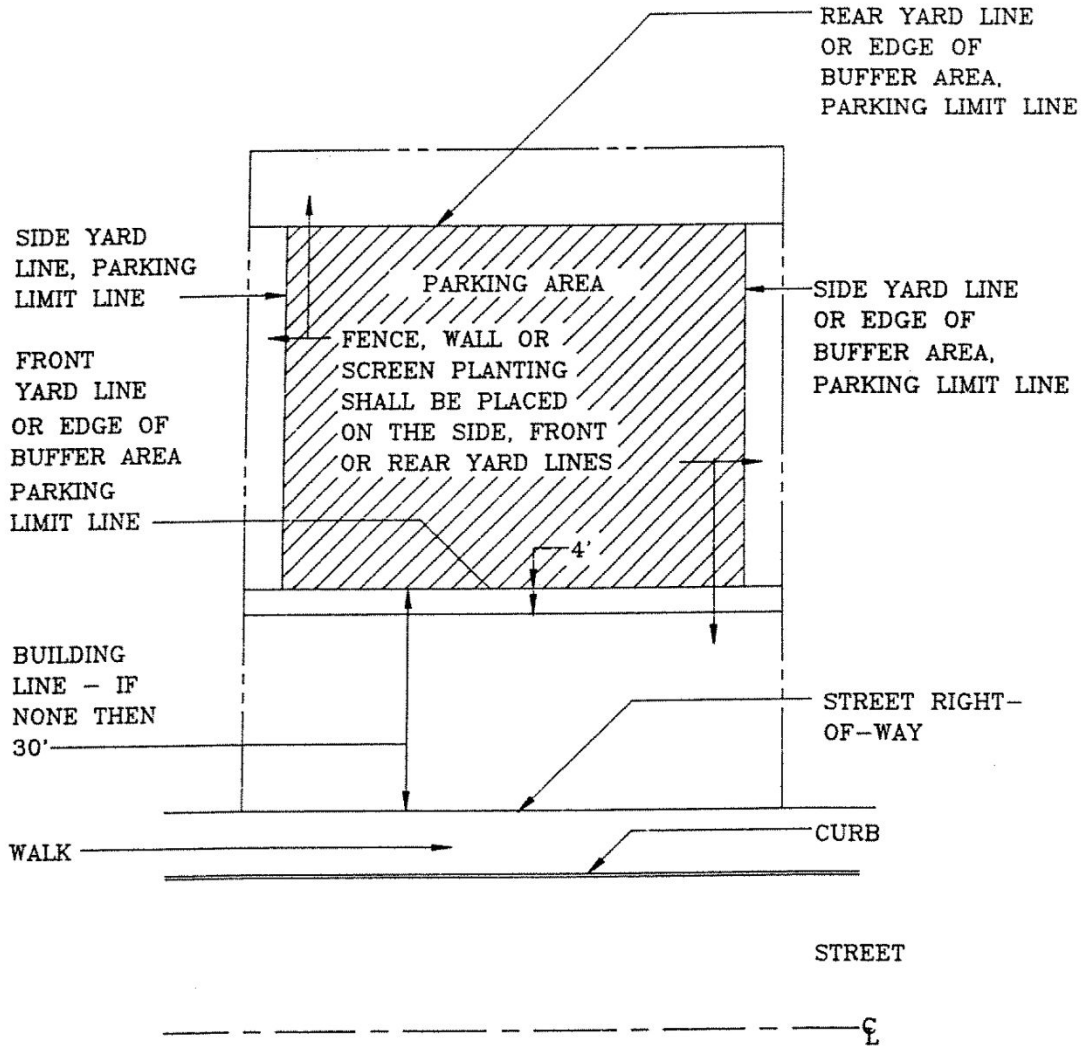

MT. LEBANON CODE

NO SCALE

90 DEGREE PARKING
ALL DISTRICTS

DIAGRAM 10

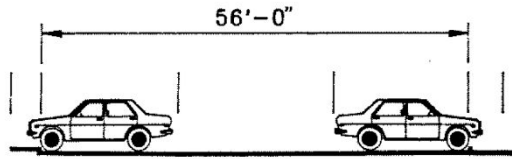

SECTION

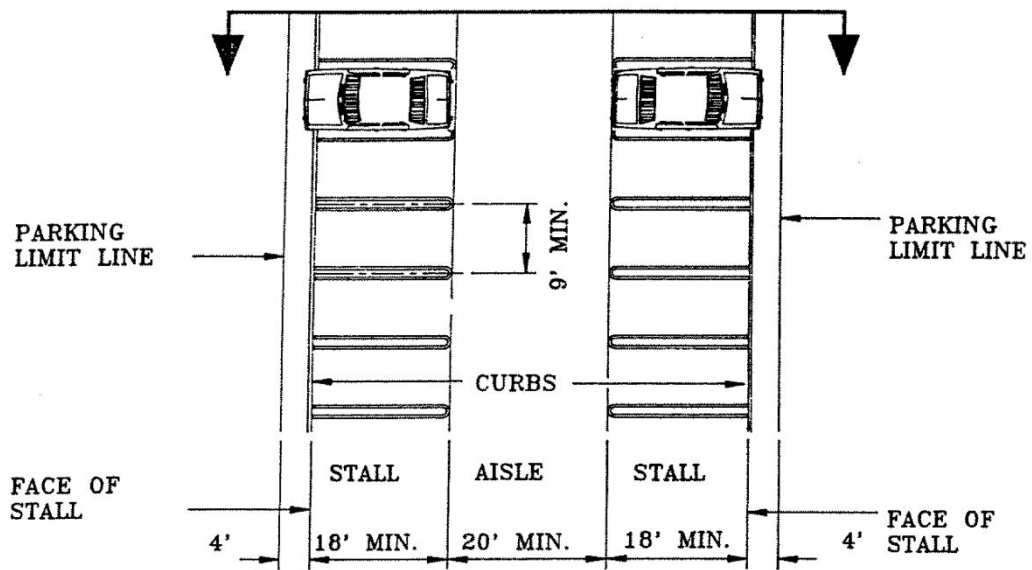

PLAN

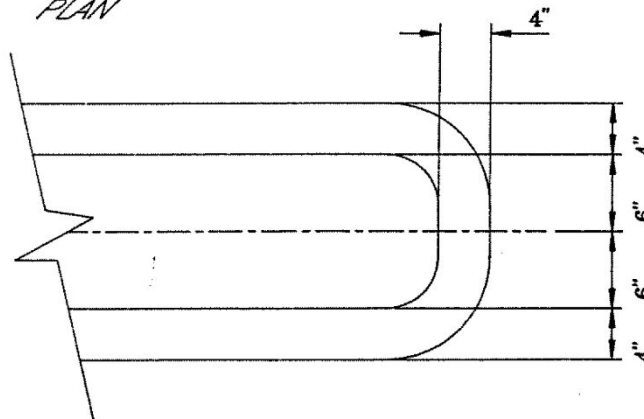

PAINT LINES

ZONING

NO SCALE

90 DEGREE PARKING
DOUBLE LOADED - ALL DISTRICTS

DIAGRAM 11

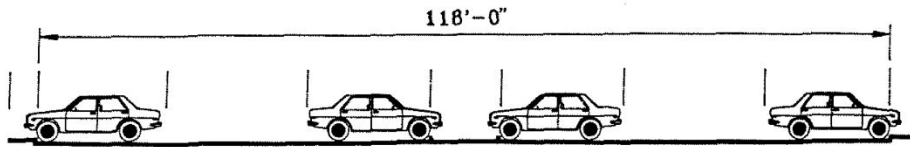

SECTION

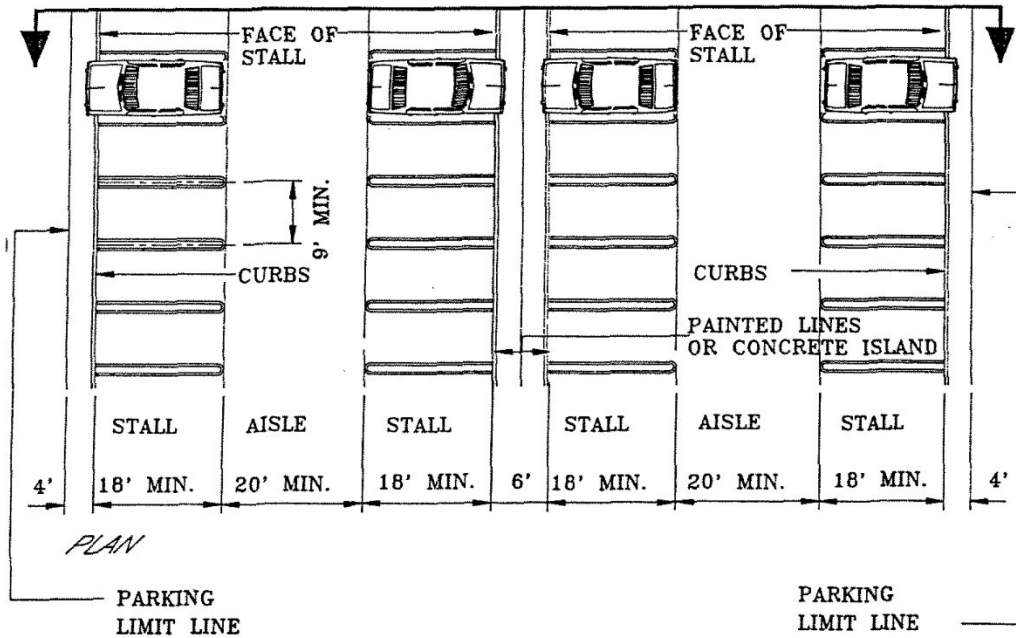

MT. LEBANON CODE

NO SCALE

60 DEGREE PARKING
ALL DISTRICTS

DIAGRAM 12

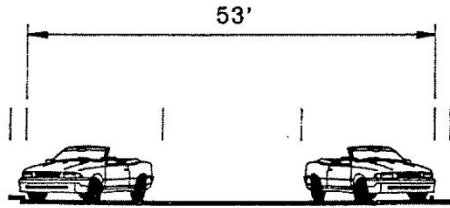

SECTION

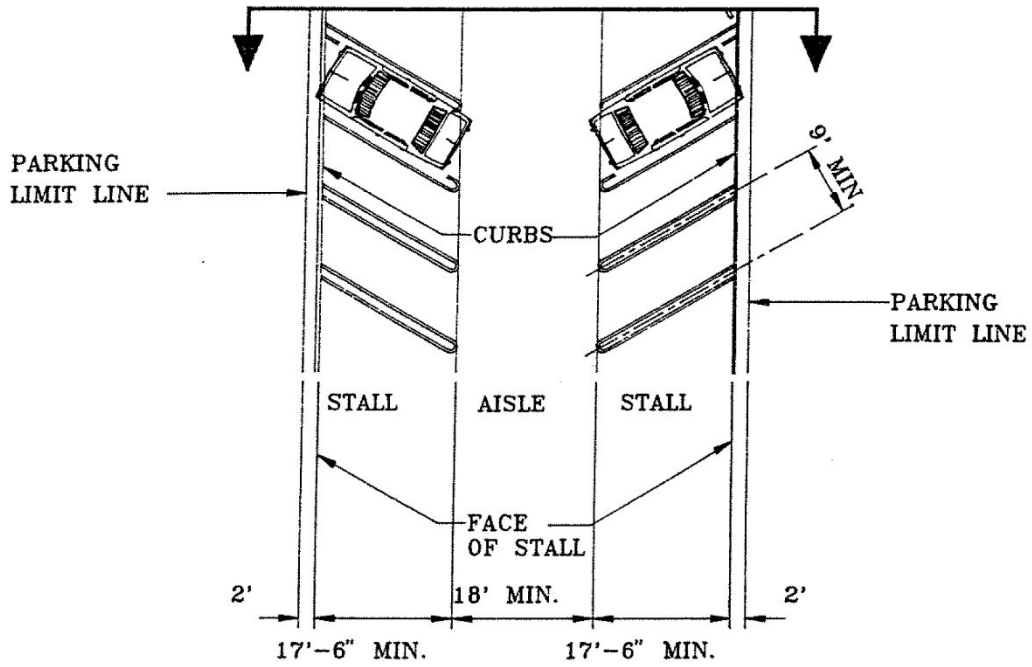

PLAN

* FOR PAINT LINES SEE DIAGRAM 10

ZONING

NO SCALE

60 DEGREE PARKING
DOUBLE LOADED - ALL DISTRICTS

DIAGRAM 13

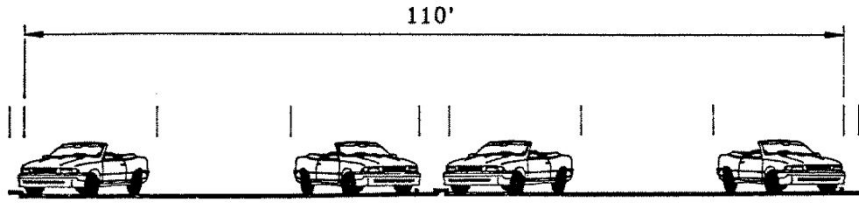

SECTION

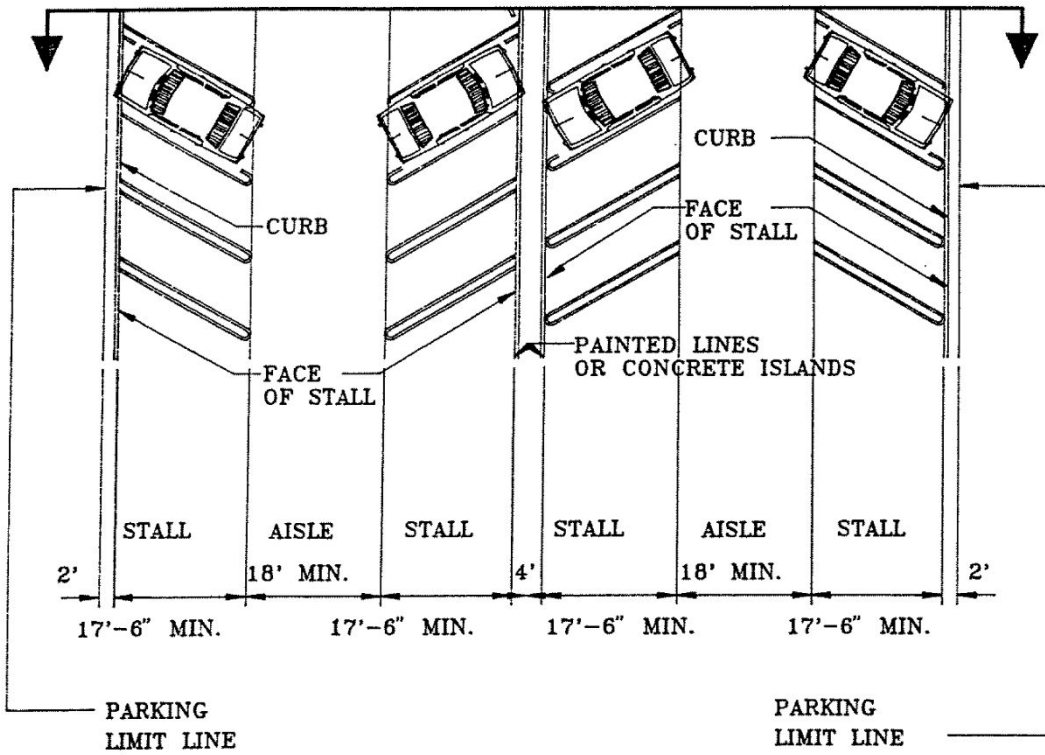

PLAN

* FOR PAINT LINES SEE DIAGRAM 10

MT. LEBANON CODE

NO SCALE

45 DEGREE PARKING
ALL DISTRICTS

DIAGRAM 14

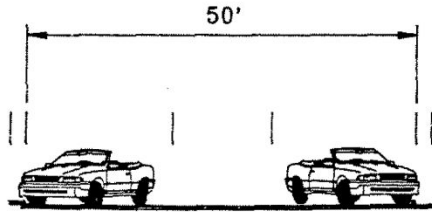

SECTION

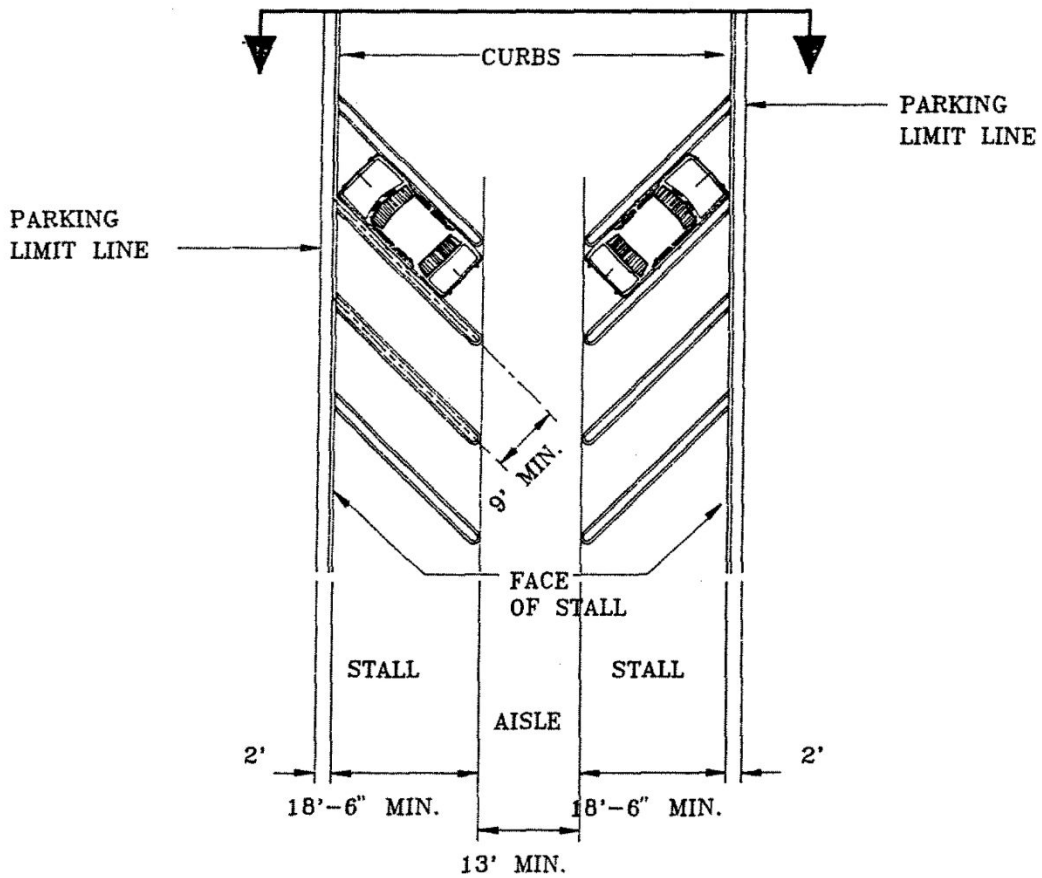

PLAN

* FOR PAINT LINES SEE DIAGRAM 10

ZONING

NO SCALE

45 DEGREE PARKING
DOUBLE LOADED - ALL DISTRICTS

DIAGRAM 15

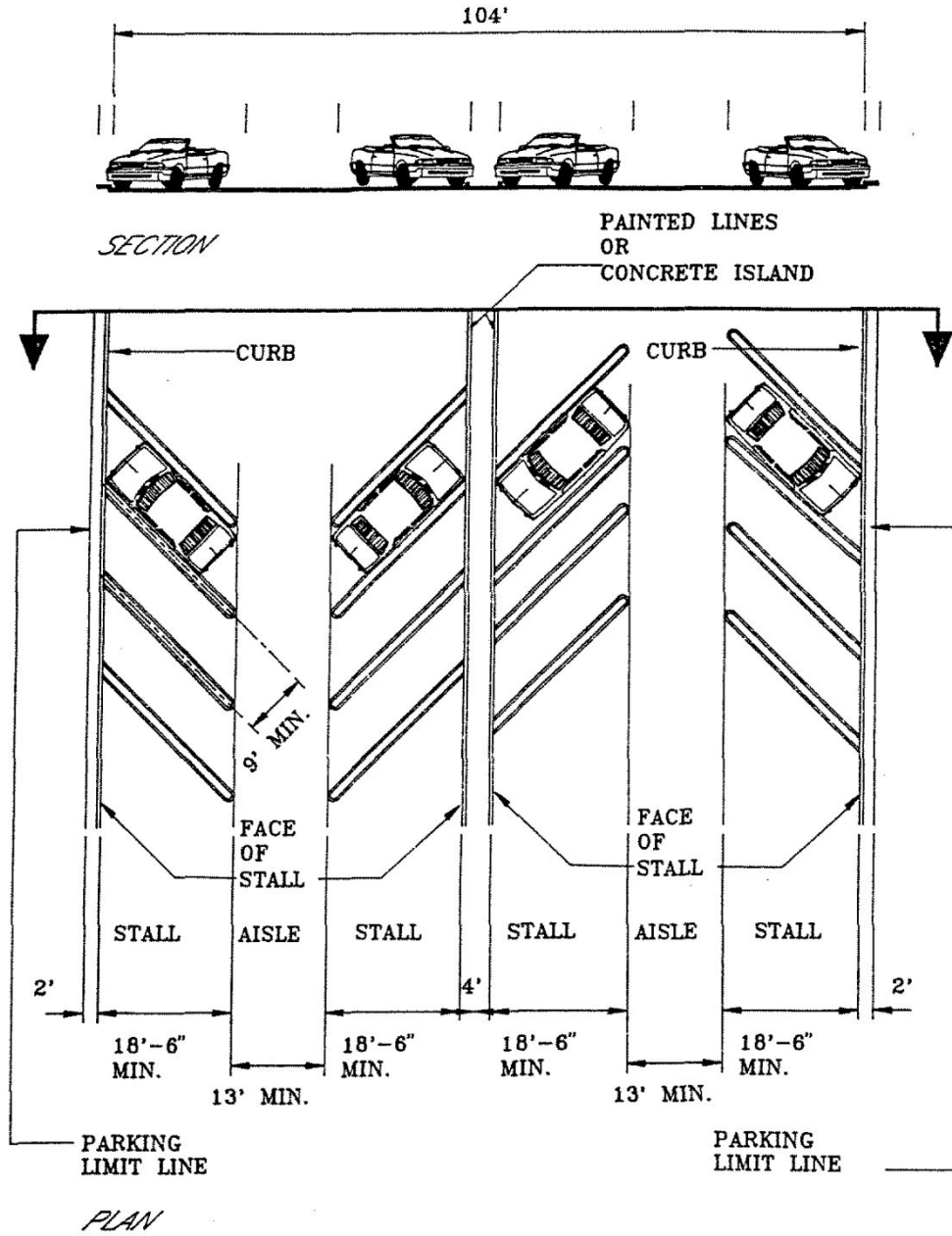

* FOR PAINT LINES SEE DIAGRAM 10

MT. LEBANON CODE

NO SCALE

ENTRANCES & EXITS

DIAGRAM 16

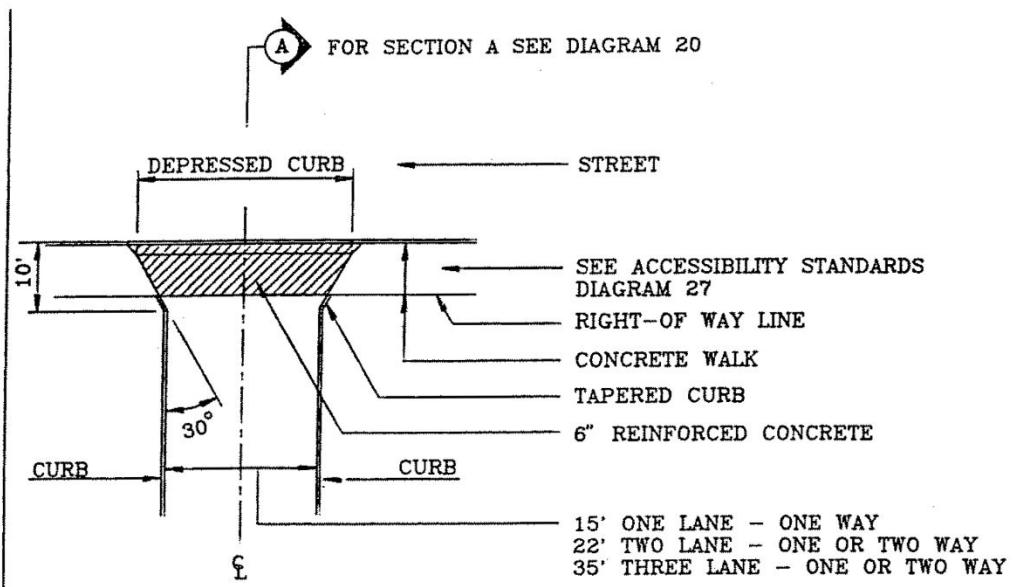

CONDITIONAL USE IN ZONING DISTRICTS R-1, R-2, R-3.
ALL USES IN ZONING DISTRICT R-4.

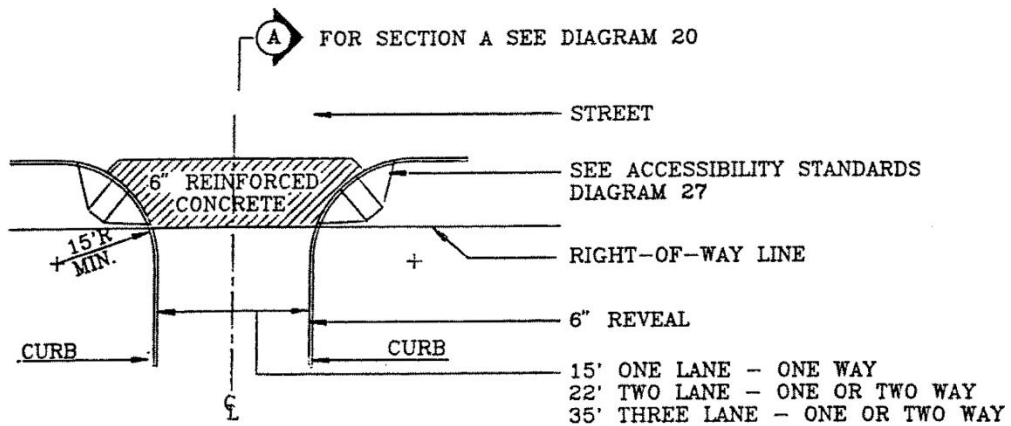

ALL OTHER DISTRICTS

ZONING

NO SCALE

RELATIONSHIP OF DRIVE TO
PROPERTY LINE AND/OR BUILDING
C & C-1 DISTRICTS

DIAGRAM 17

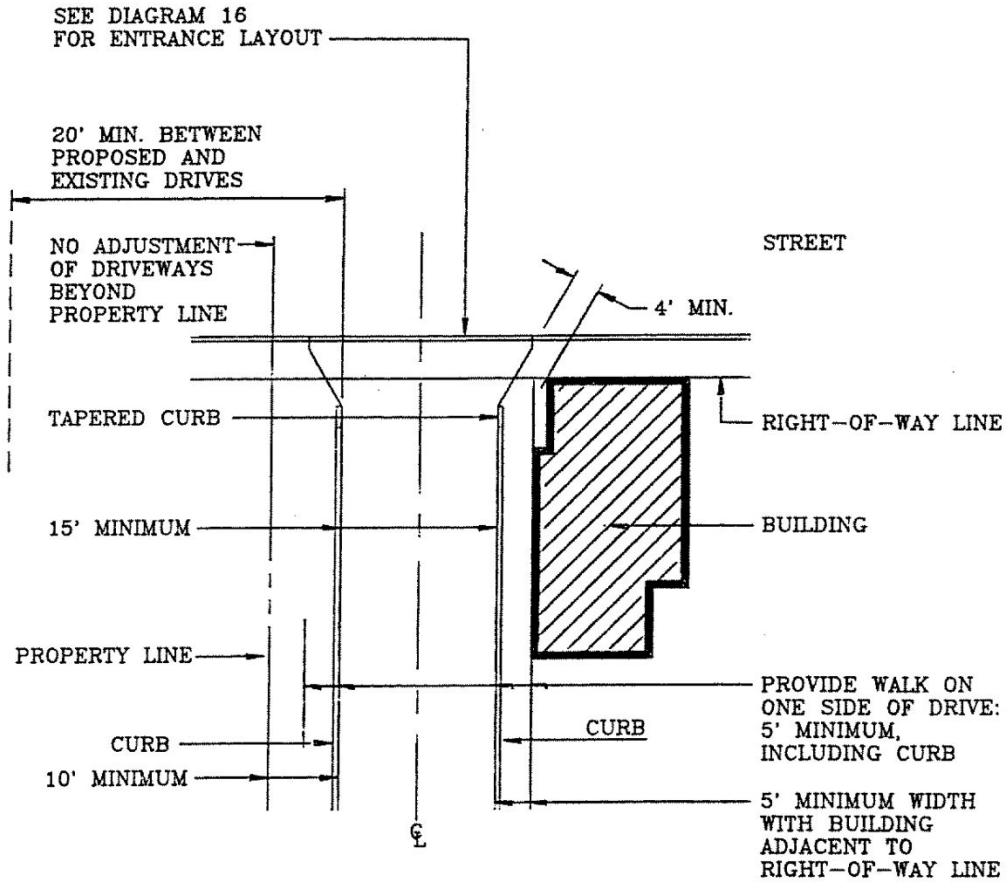

MT. LEBANON CODE

NO SCALE

RELATION OF DRIVE TO INTERSECTION

DIAGRAM 18

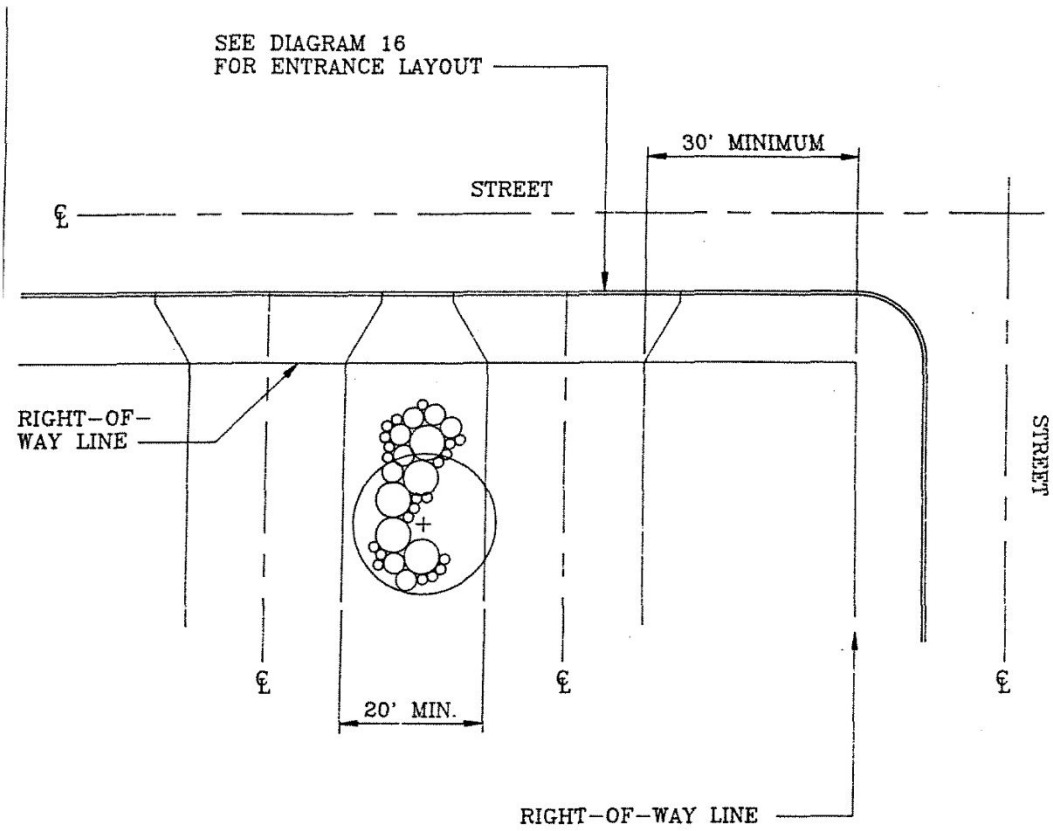

ZONING

NO SCALE

OBLIQUE DRIVES ONLY

DIAGRAM 19

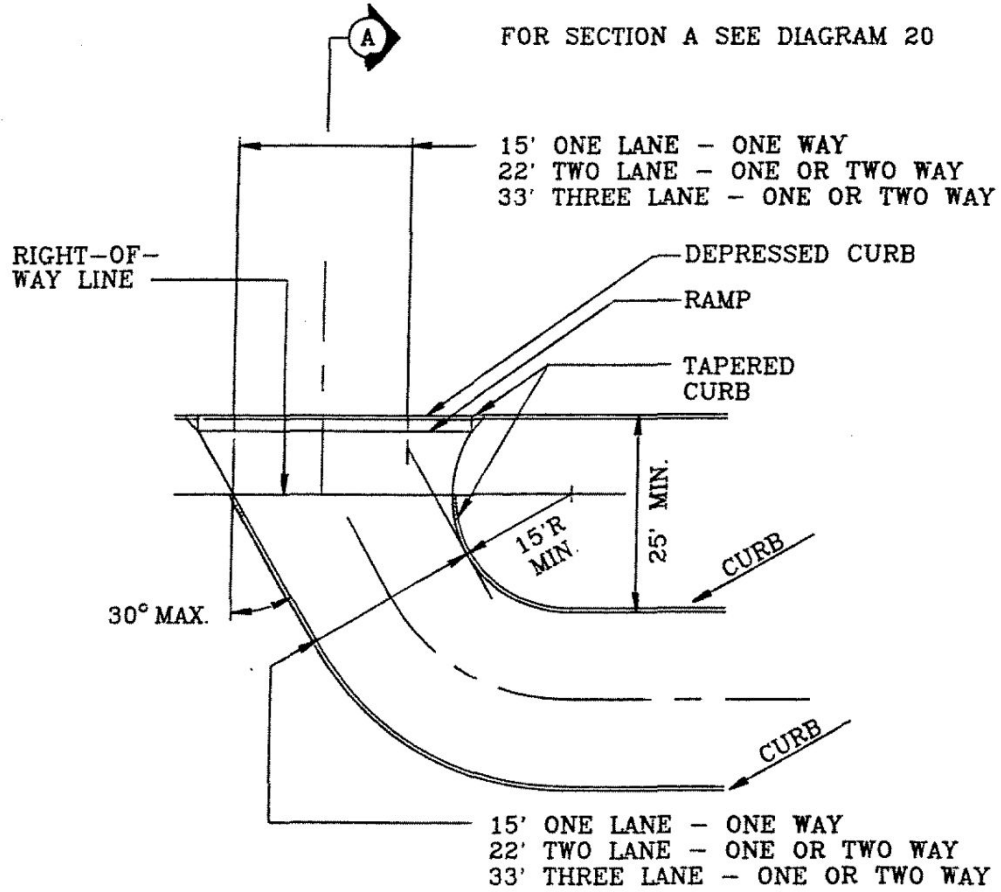

MT. LEBANON CODE

NO SCALE

SECTION A
ENTRANCE & EXIT DRIVE

DIAGRAM 20

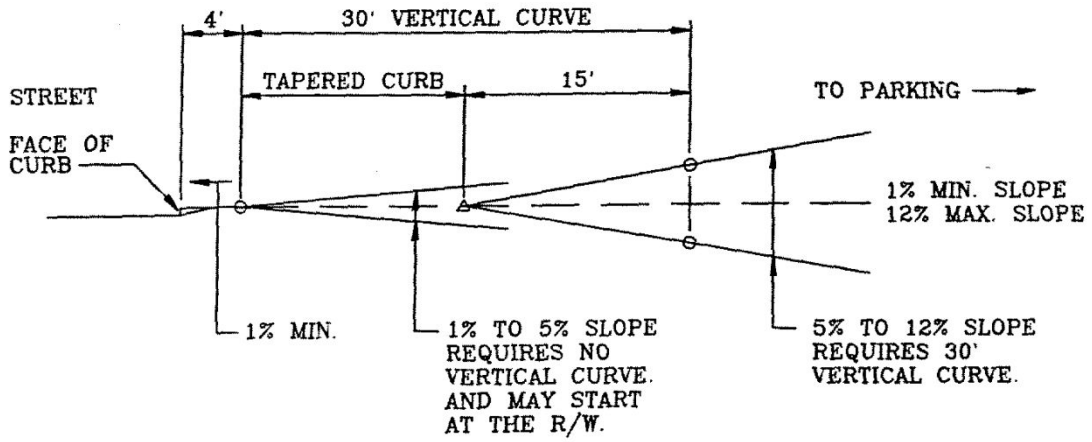

ZONING

NO SCALE

PERMISSABLE PARKING GRADIENTS

DIAGRAM 21

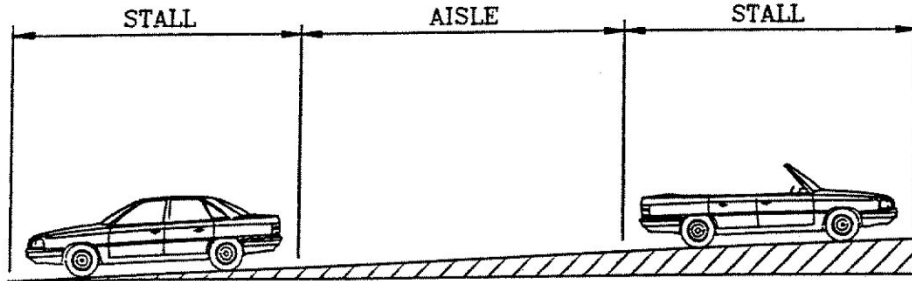

5% MAXIMUM CROSS SLOPE PERMITTED

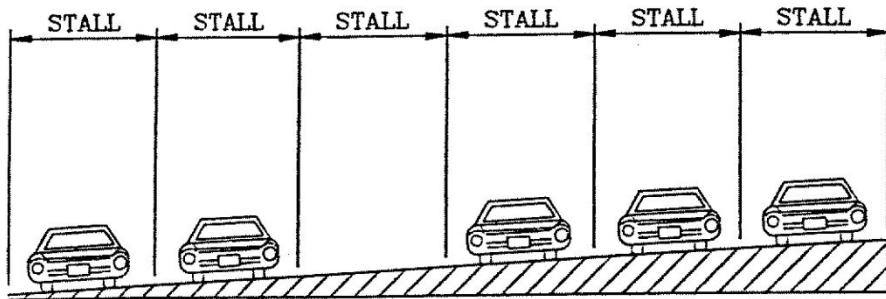

7% MAXIMUM LONGITUDINAL SLOPE PERMITTED

MT. LEBANON CODE

NO SCALE

SLOPE TREATMENT
TYPICAL SECTIONS

DIAGRAM 22

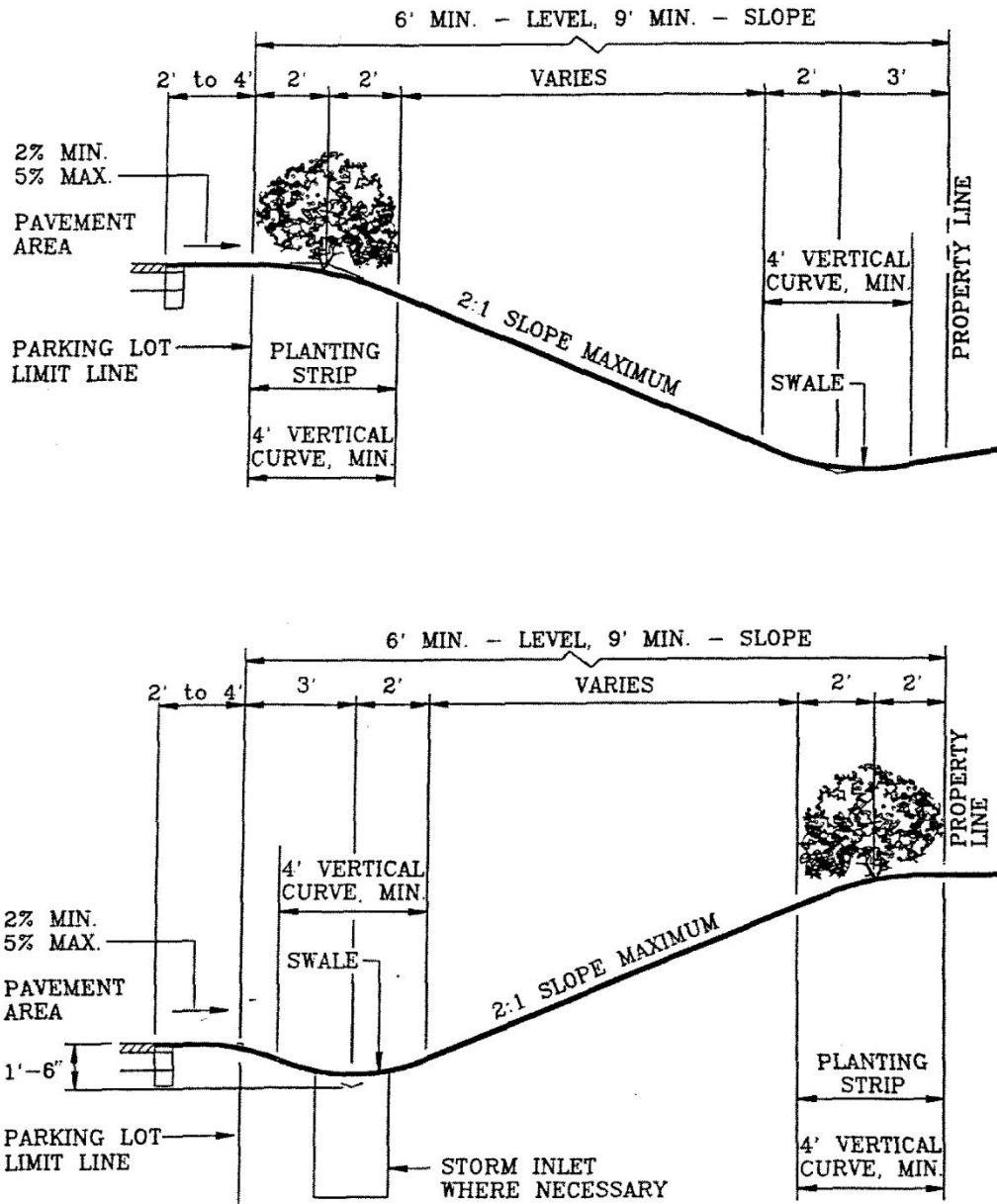

ZONING

NO SCALE

STORM DRAINAGE
PARKING AREAS

DIAGRAM 23

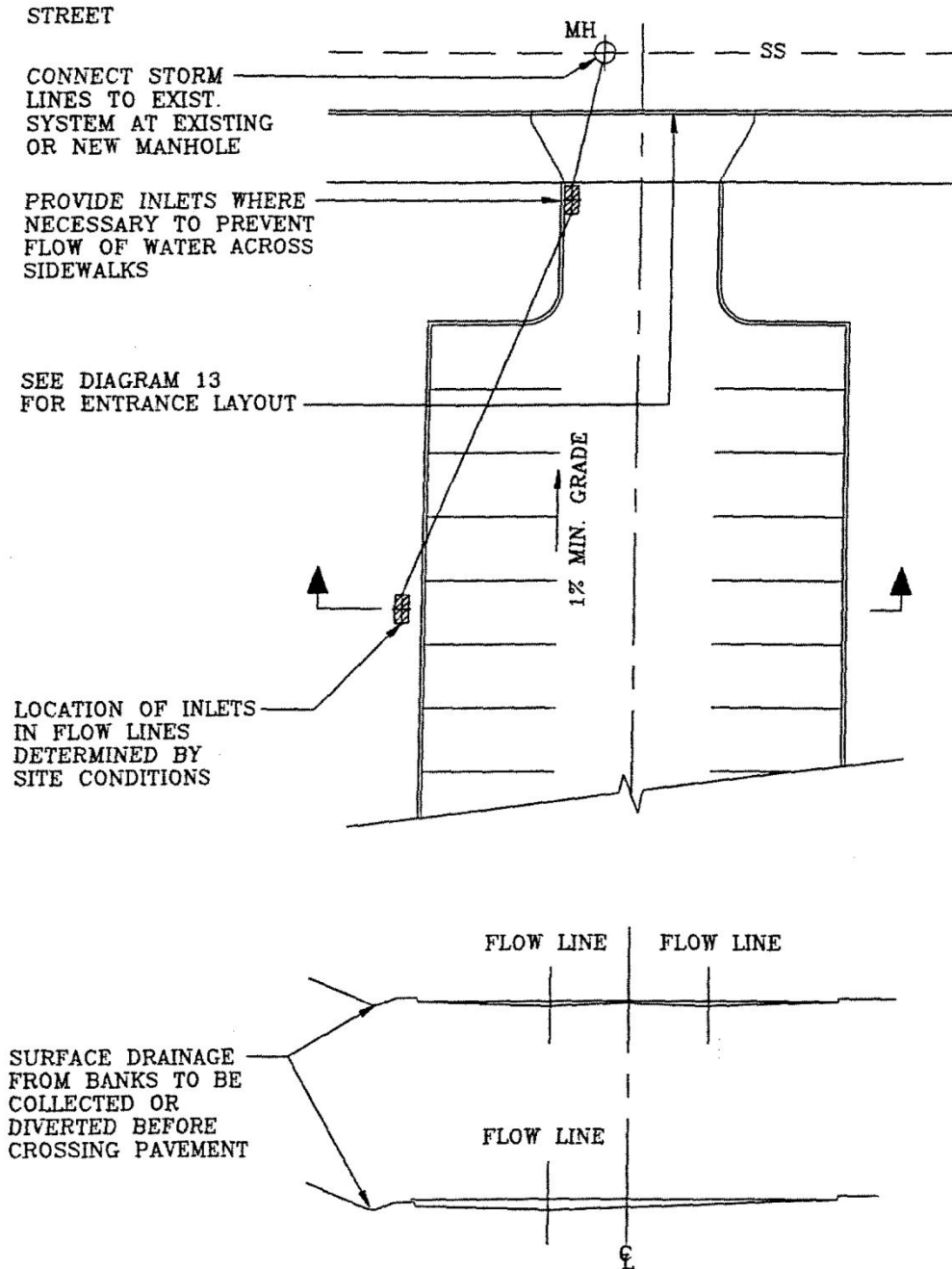

MT. LEBANON CODE

NO SCALE

TREE PLANTING
DECIDUOUS

DIAGRAM 24

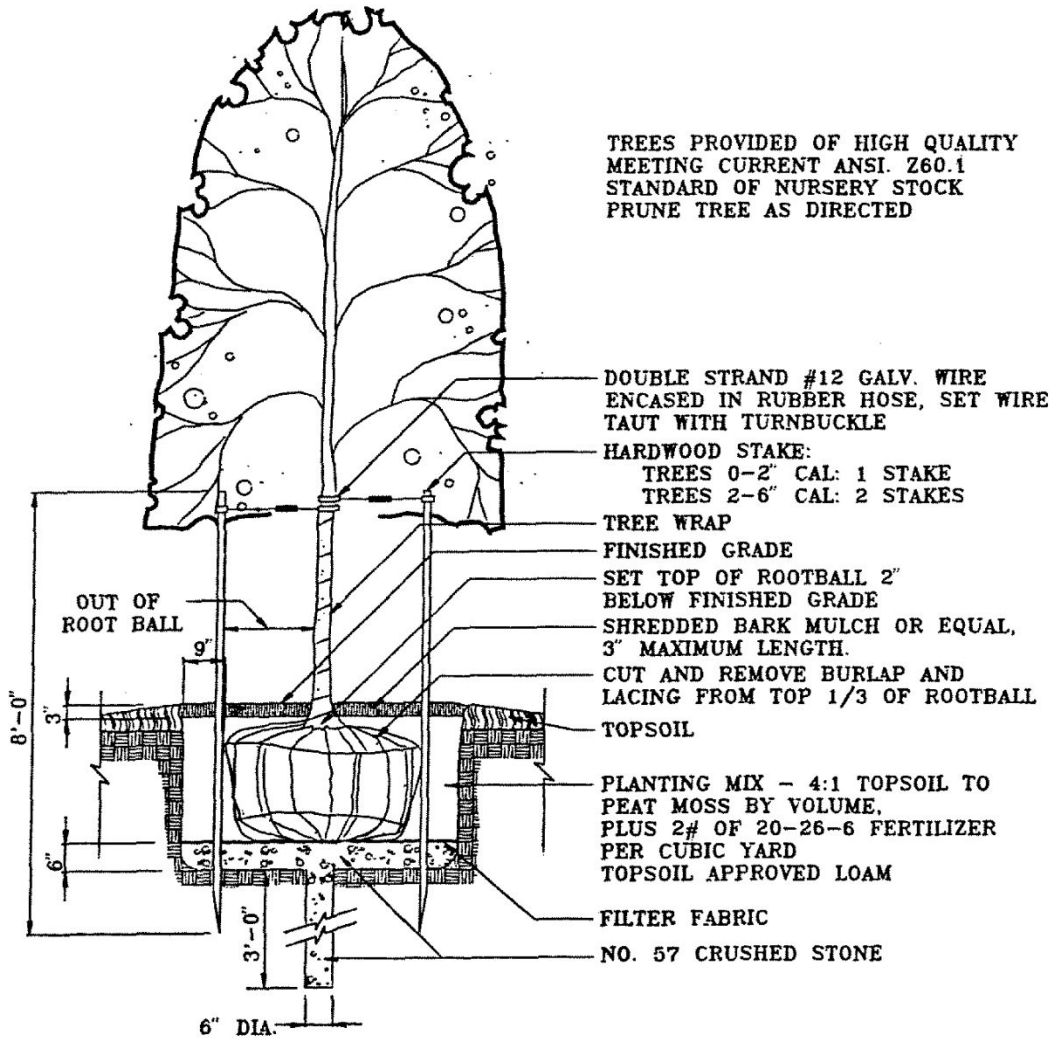

ZONING

NO SCALE

TREE PLANTING
EVERGREEN

DIAGRAM 25

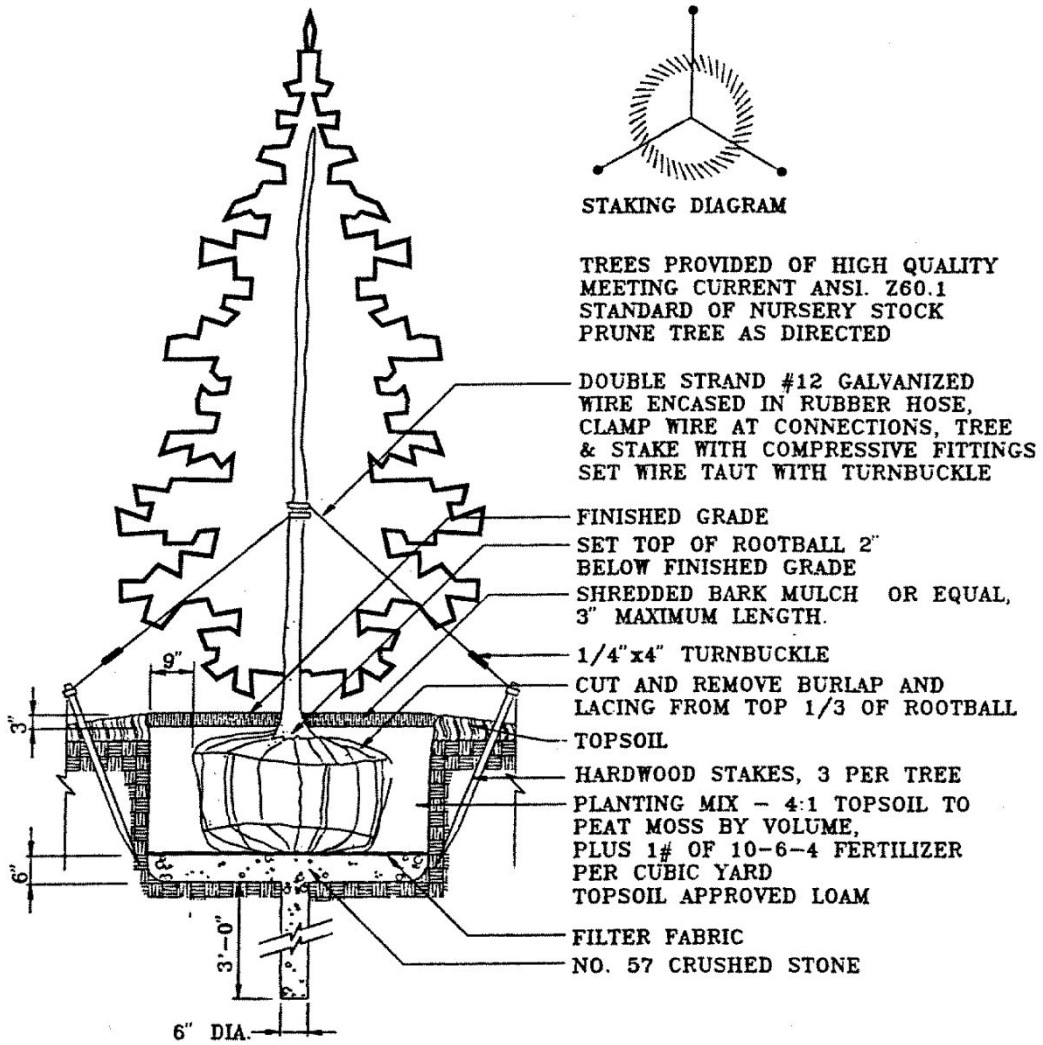

MT. LEBANON CODE

NO SCALE

SHRUB & HEDGE PLANTING

DIAGRAM 26

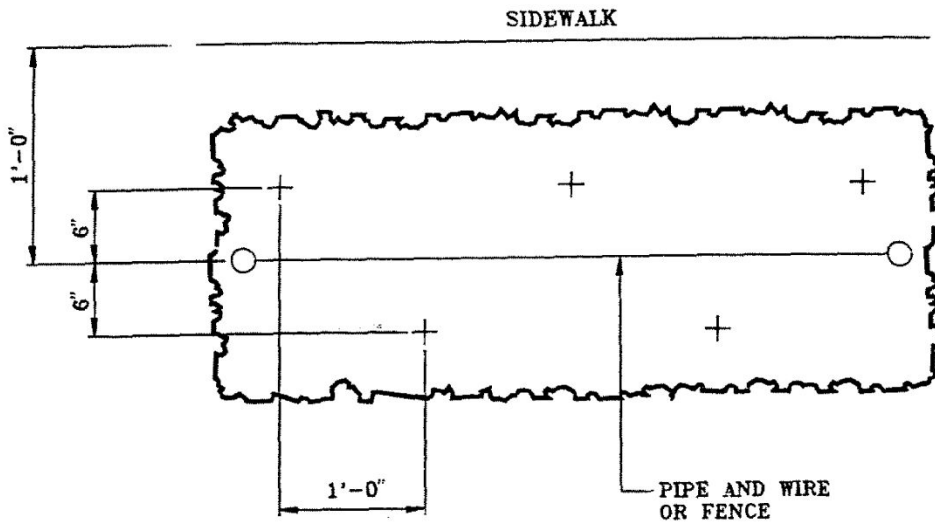
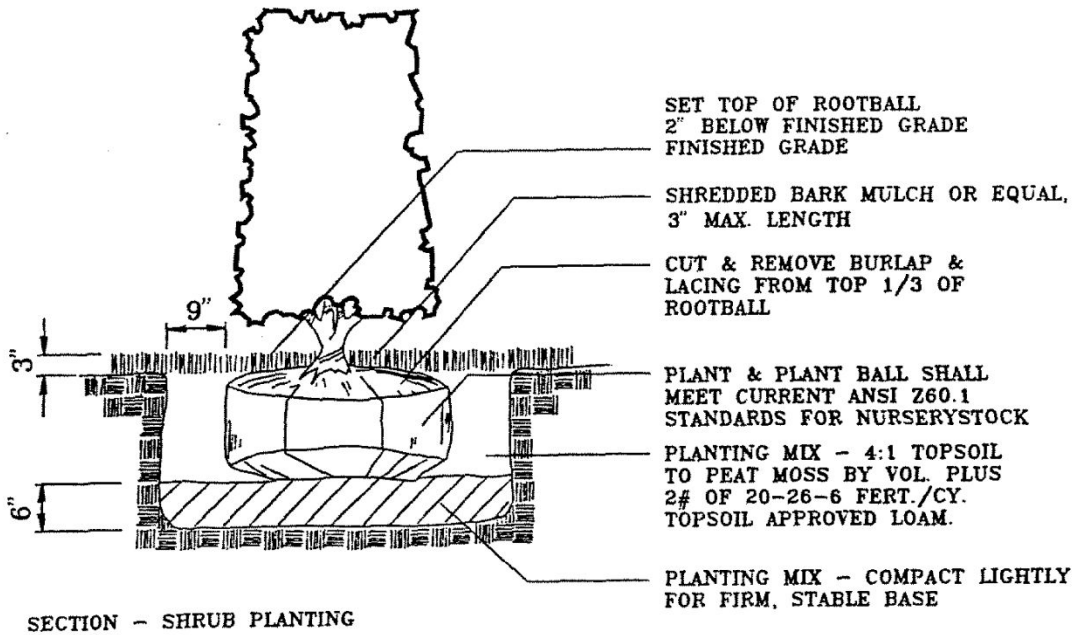

ZONING

NO SCALE

STREET TREE PLANTING
COMMERCIAL DISTRICT

DIAGRAM 27

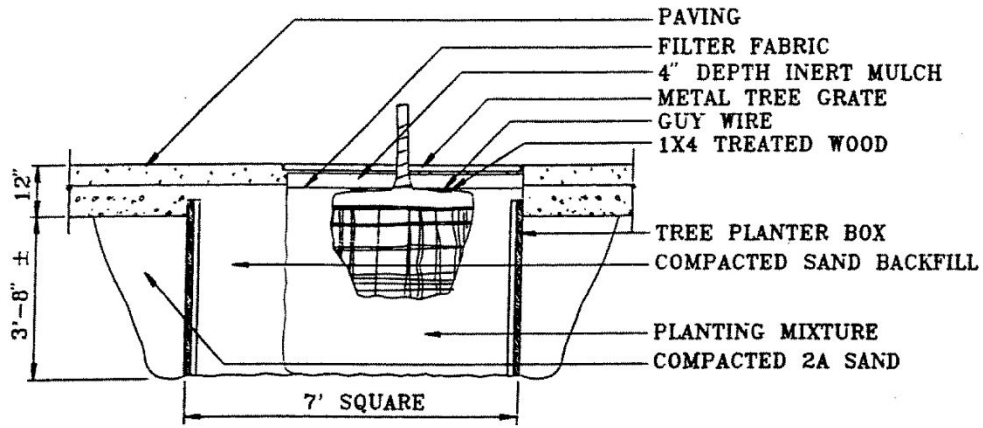

SECTION

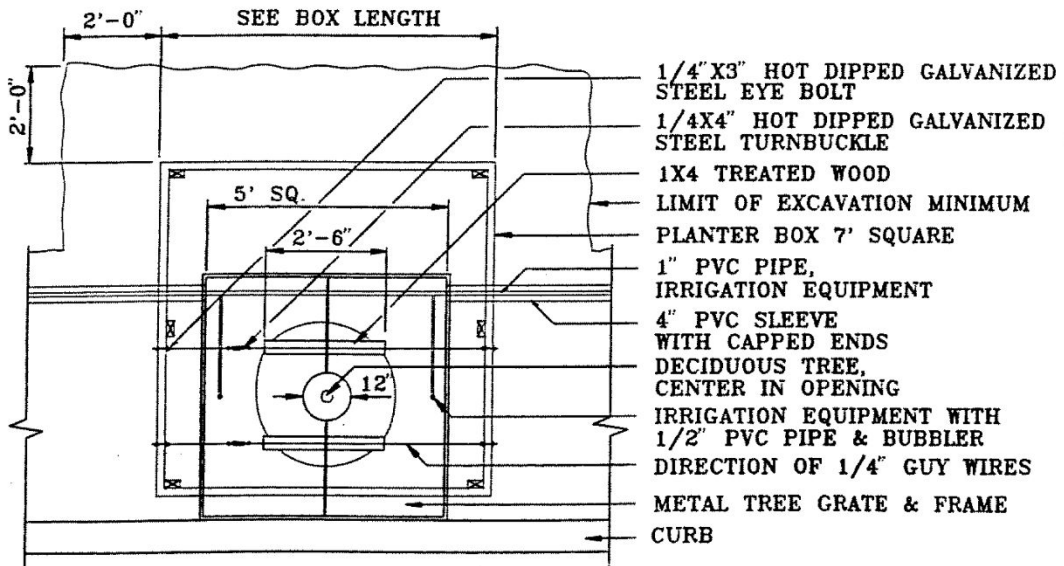

PLAN

MT. LEBANON CODE

NO SCALE

CLEAR SIGHT TRIANGLE

DIAGRAM 28

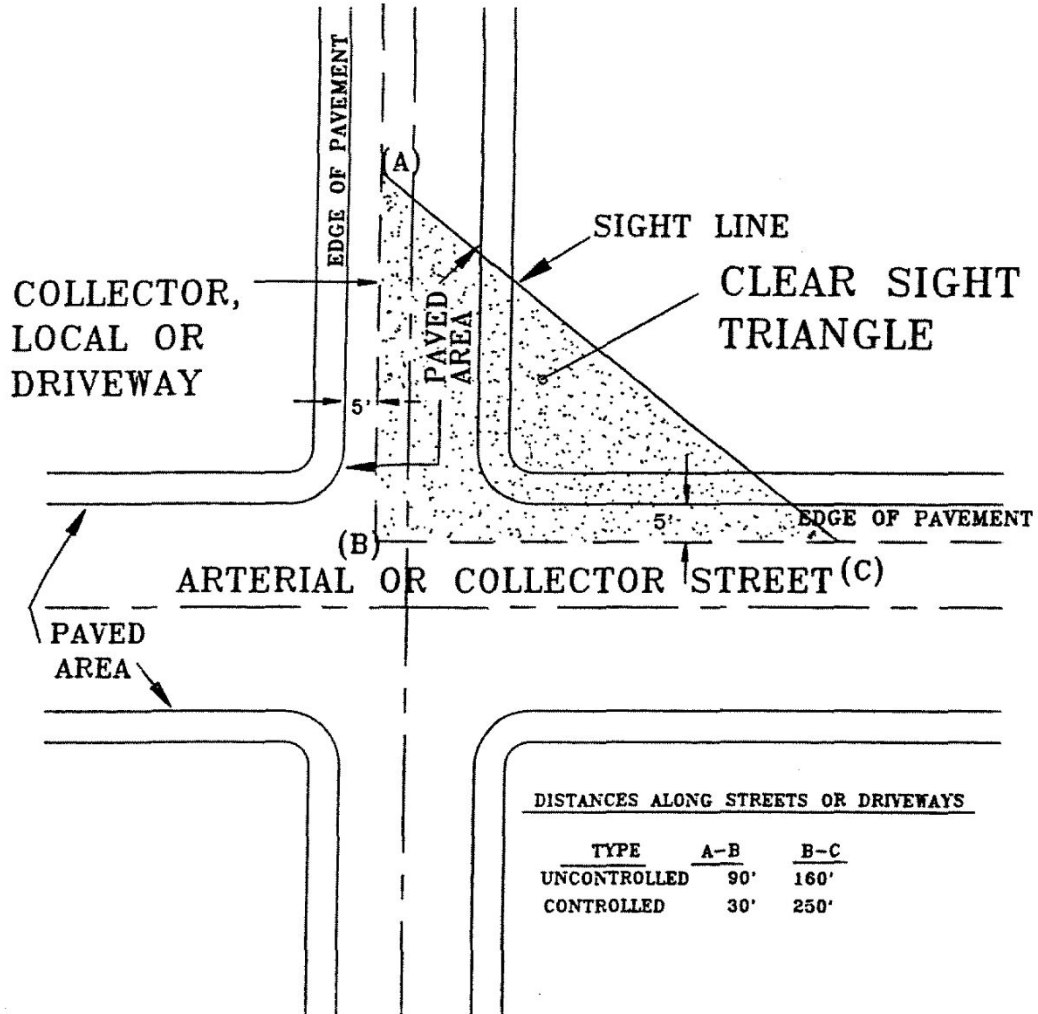

ZONING

NO SCALE

STACKED PARKING

DIAGRAM 29

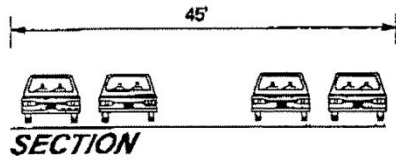

* Stacks shall contain no more than 5 vehicles in depth before a twenty (20) foot maneuvering aisle is required.

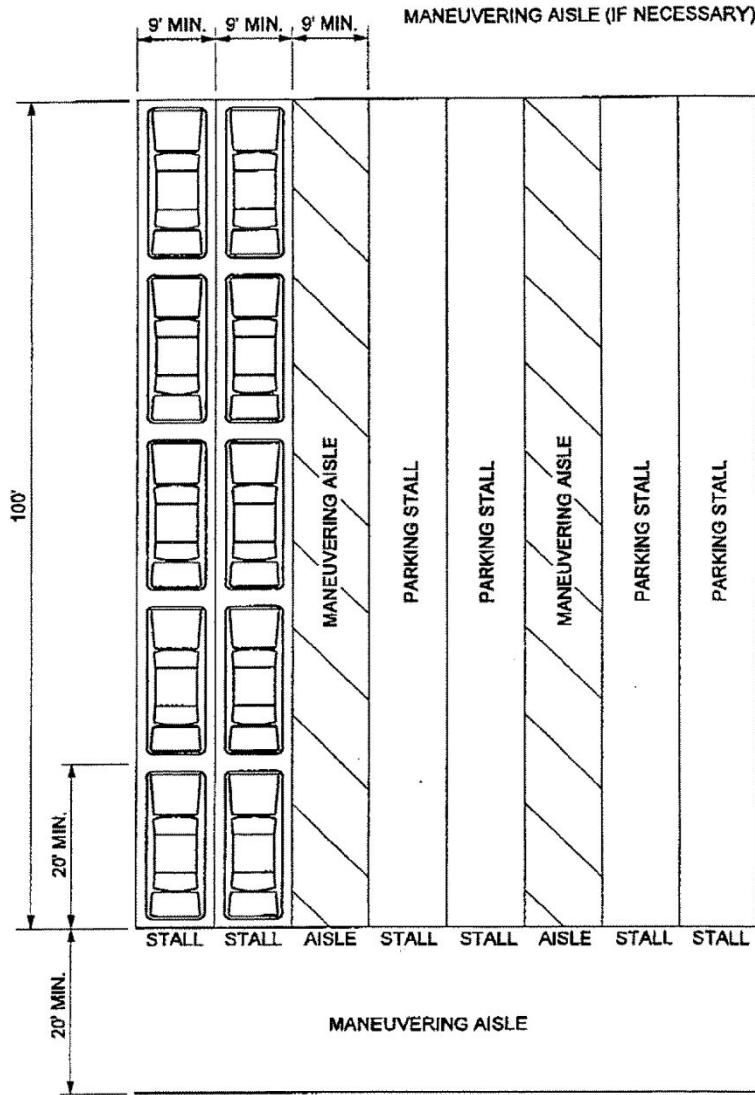

MT. LEBANON CODE

NO SCALE

ALL OTHER RESIDENTIAL DISTRICTS
AC UNITS

DIAGRAM 30

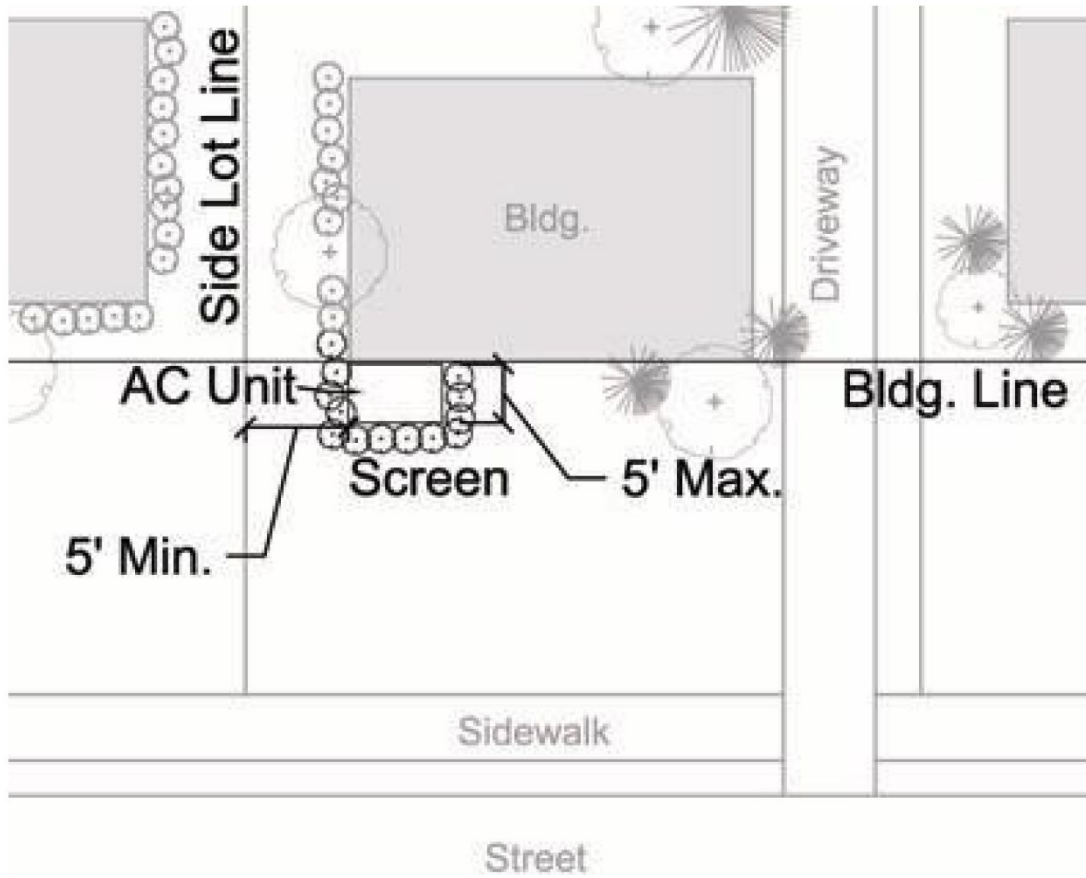

ZONING

NO SCALE

VEHICLE RENTAL

DIAGRAM 31

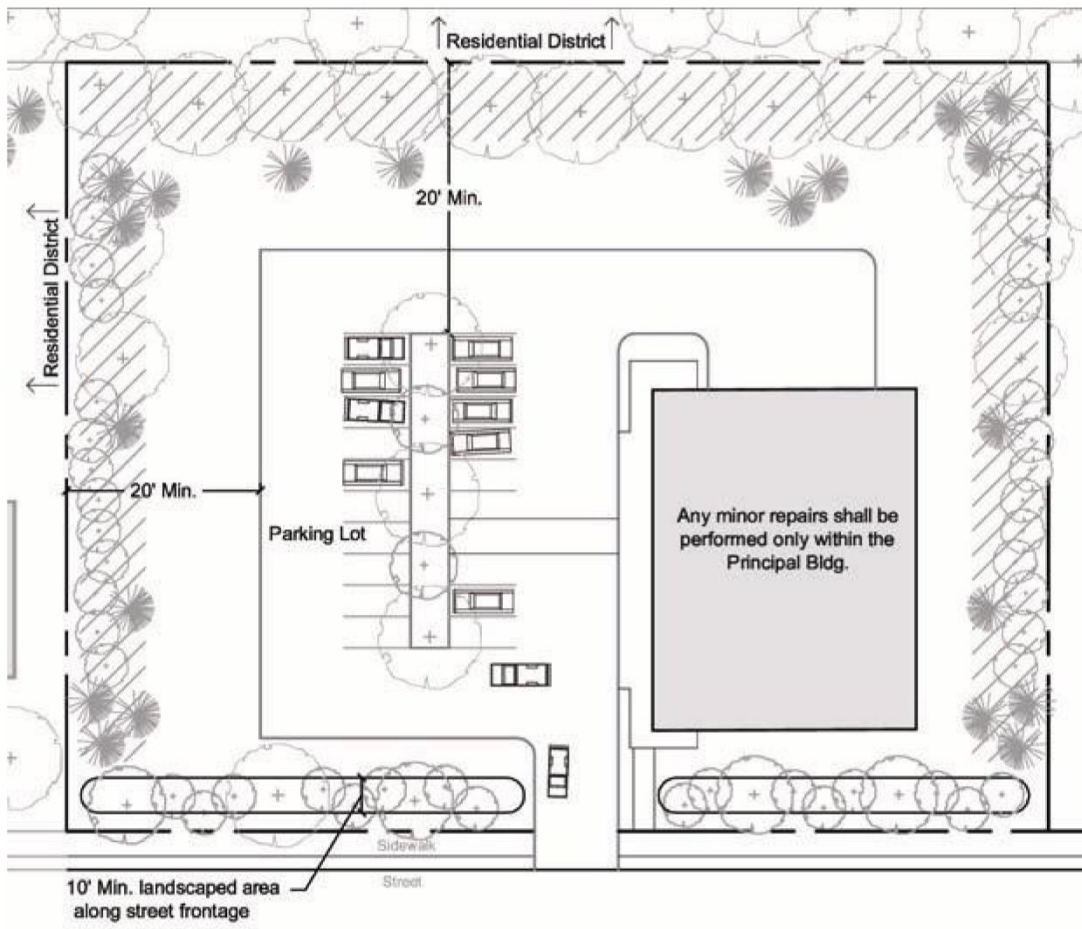

MT. LEBANON CODE

NO SCALE

LIGHTING

DIAGRAM 32

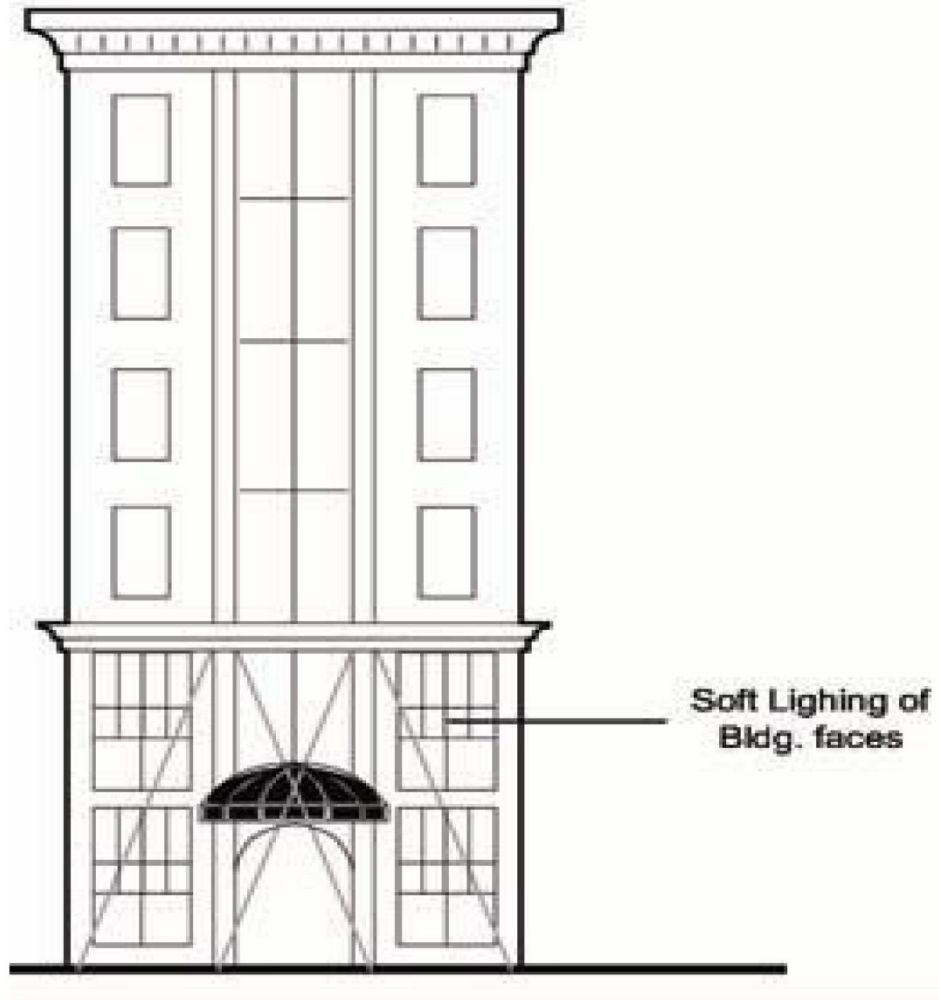

ZONING

NO SCALE

RESIDENTIAL DS - CONTEXT

DIAGRAM 33

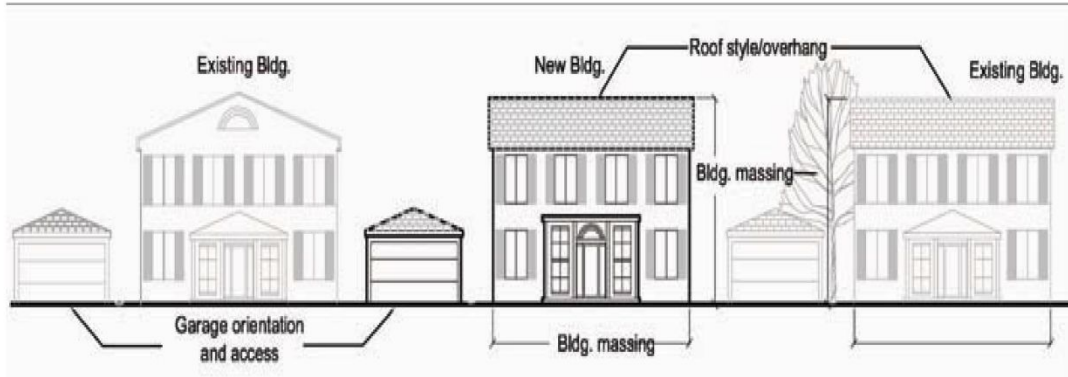

MT. LEBANON CODE

NO SCALE

R1 - R2 AC UNITS

DIAGRAM 34

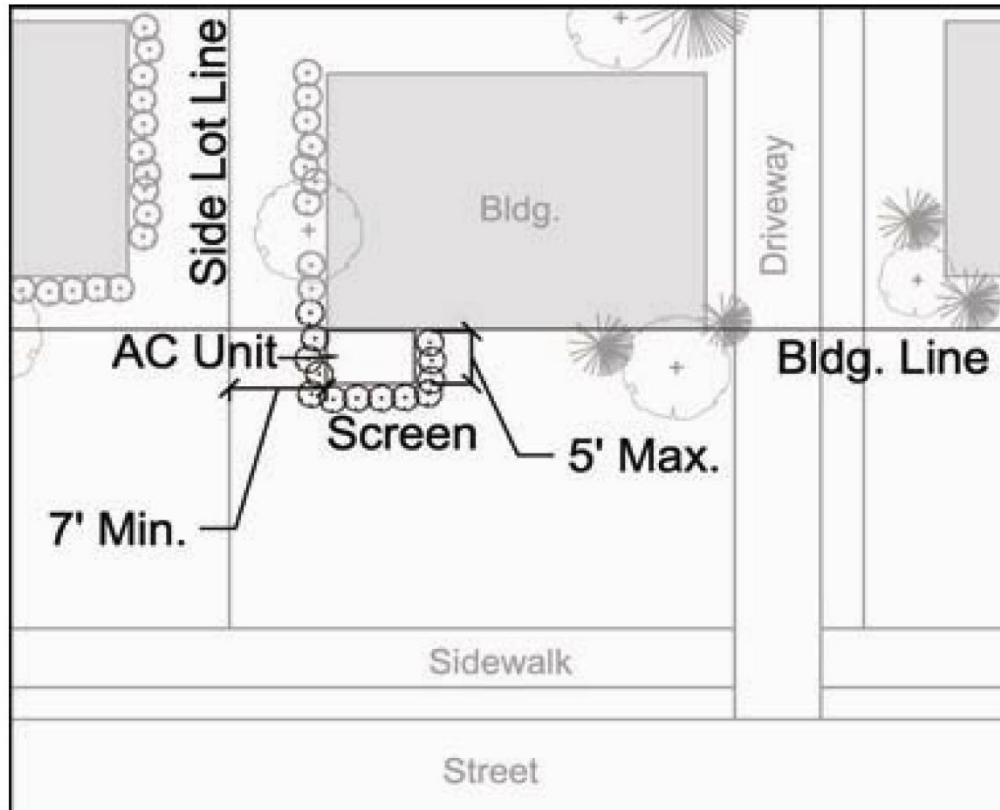

ZONING

NO SCALE

RESIDENTIAL LIGHTING

DIAGRAM 35

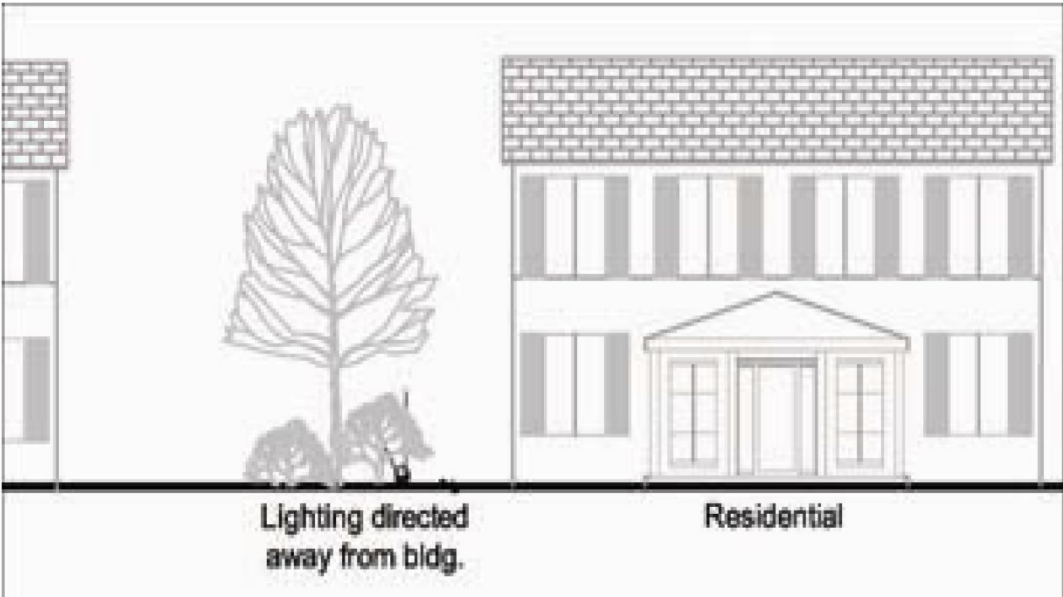

MT. LEBANON CODE

NO SCALE

SCREENING

DIAGRAM 36

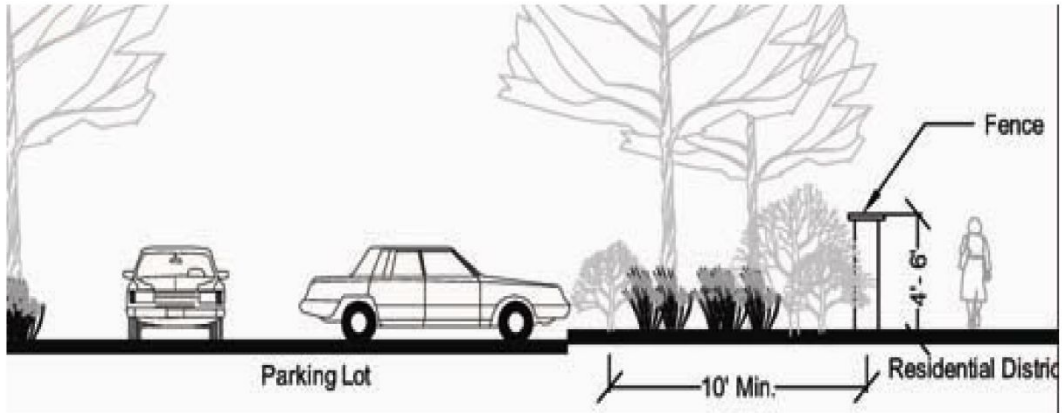

ZONING

NO SCALE

SECURITY LIGHTING

DIAGRAM 37

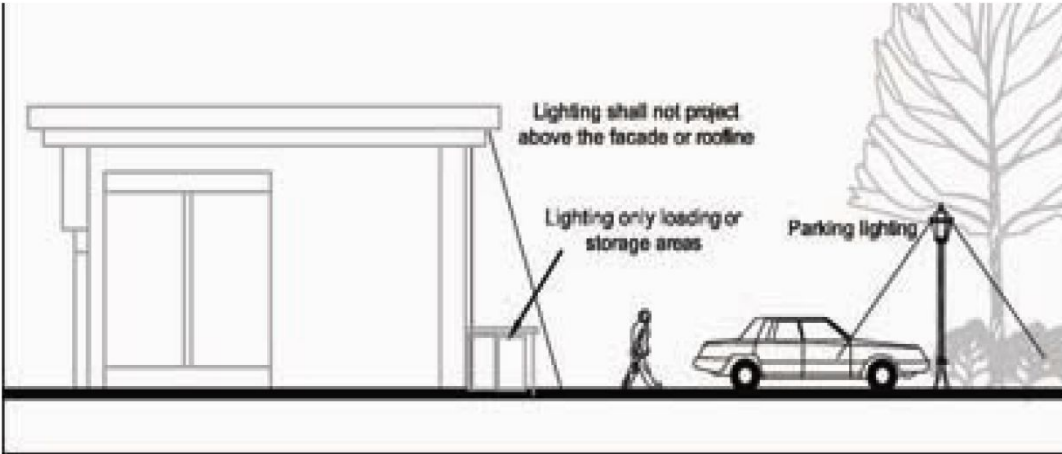

MT. LEBANON CODE

NO SCALE

VEHICLE SALES

DIAGRAM 38

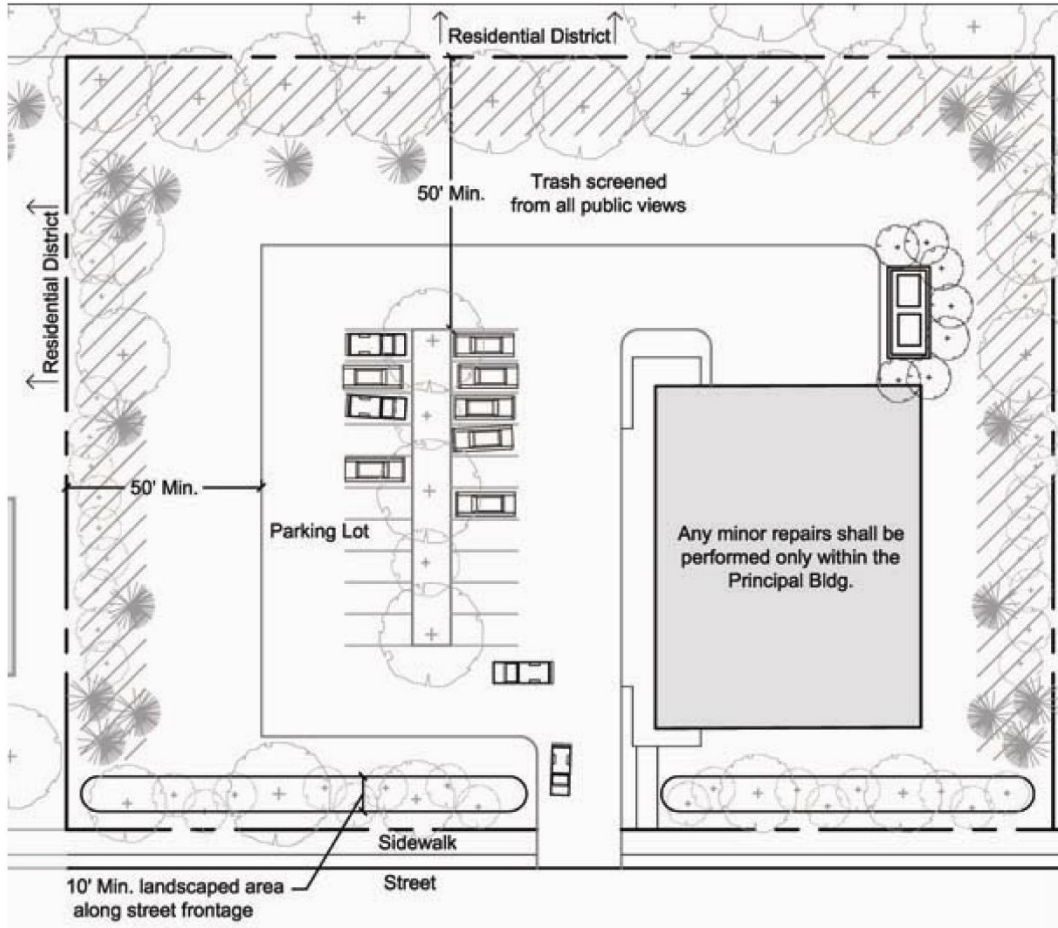

ZONING

NO SCALE

VEHICLE REPAIR

DIAGRAM 39

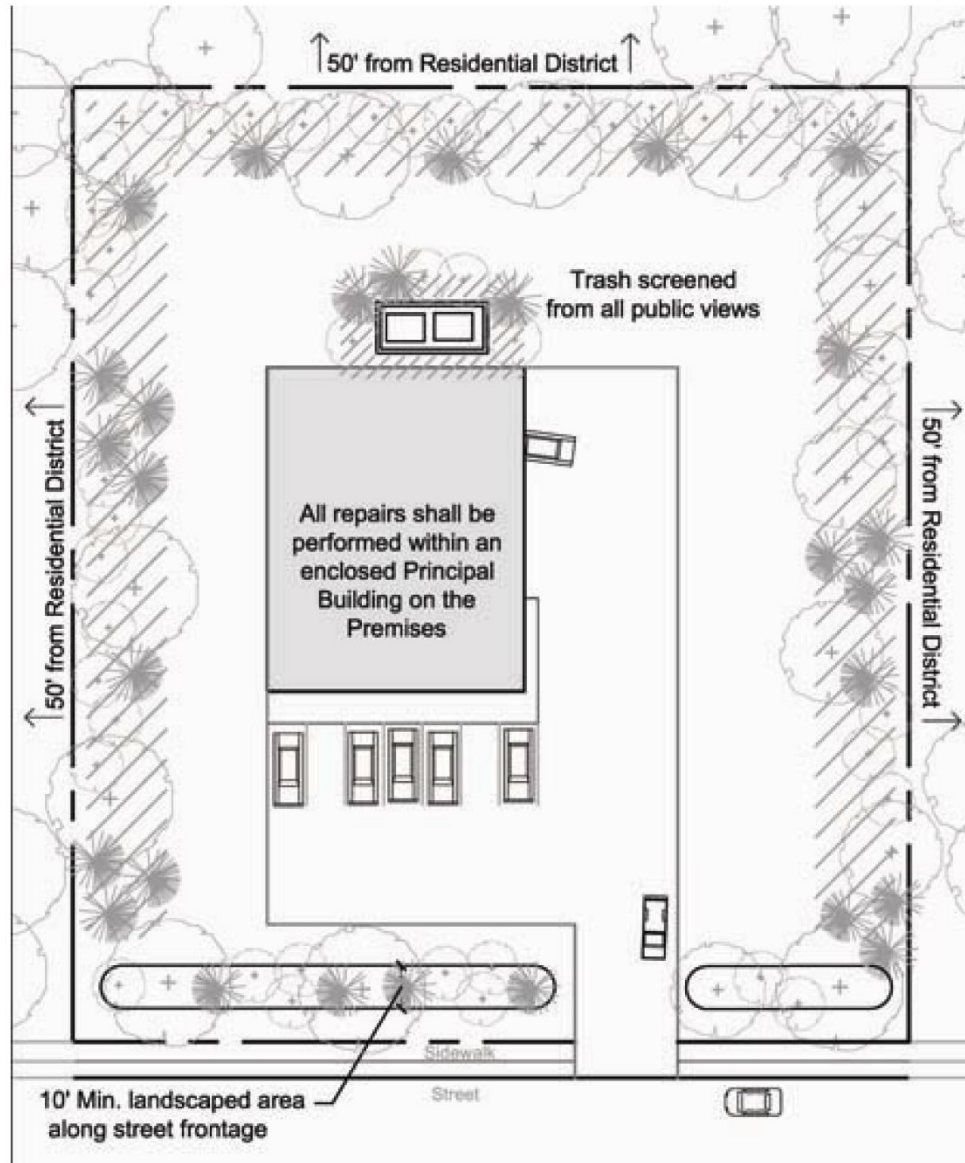

MT. LEBANON CODE

NO SCALE

R2 - RESIDENTIAL

DIAGRAM 40



ZONING

NO SCALE

C2 - RESIDENTIAL

DIAGRAM 41

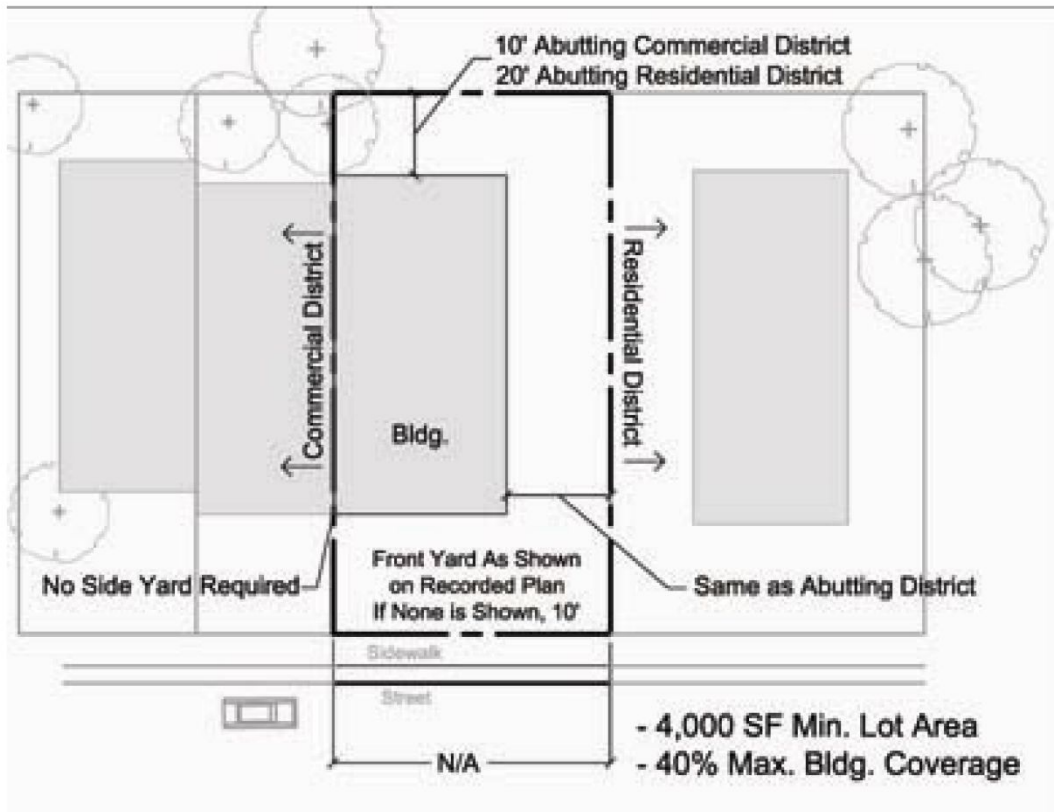

MT. LEBANON CODE

NO SCALE

C2 - RESIDENTIAL

DIAGRAM 42

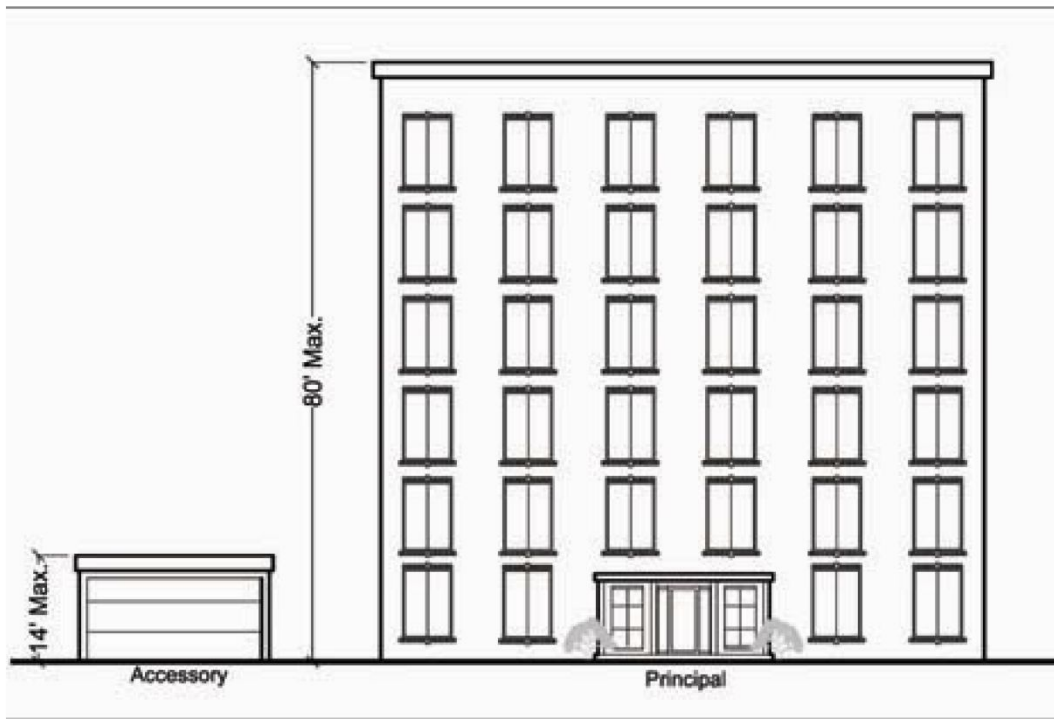

ZONING

NO SCALE

C2 -RESIDENTIAL

DIAGRAM 43

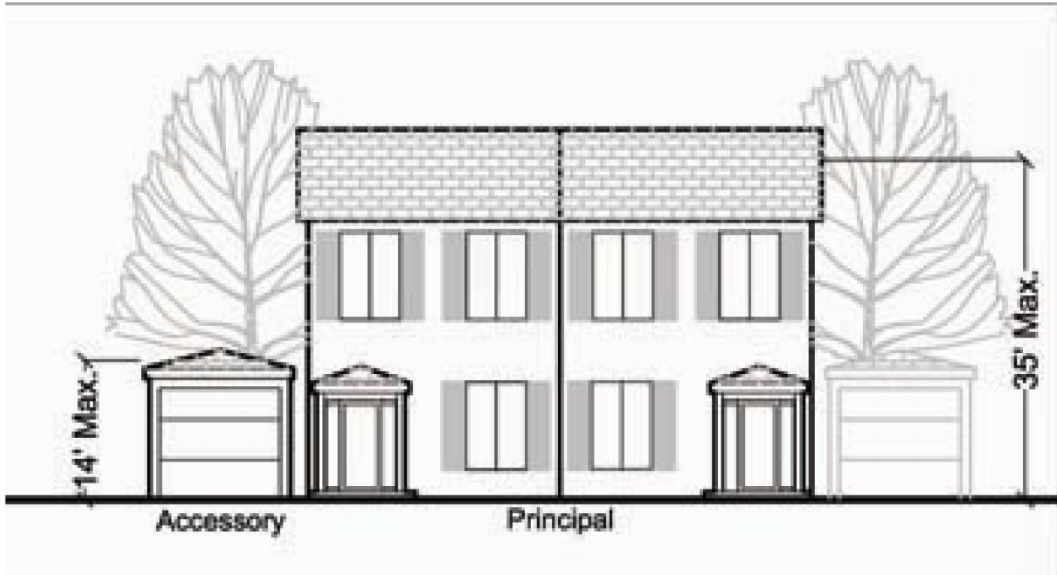

MT. LEBANON CODE

NO SCALE

CBD RESIDENTIAL

DIAGRAM 44

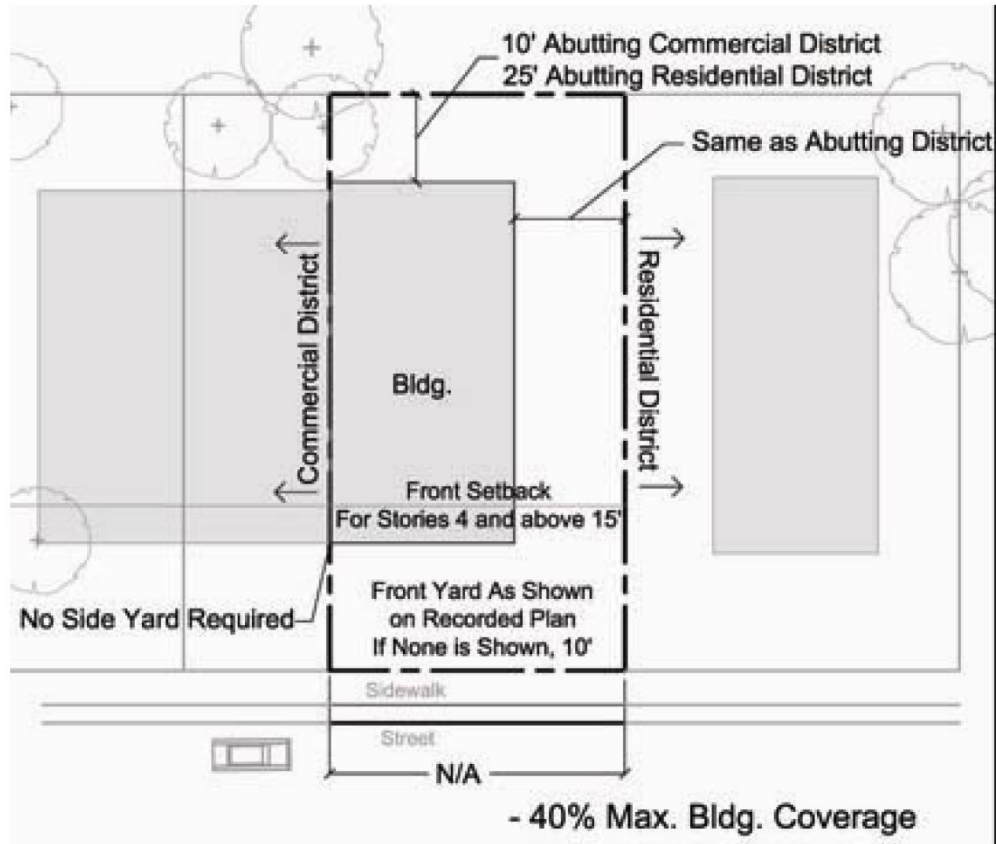

ZONING

NO SCALE

CBD RESIDENTIAL

DIAGRAM 45

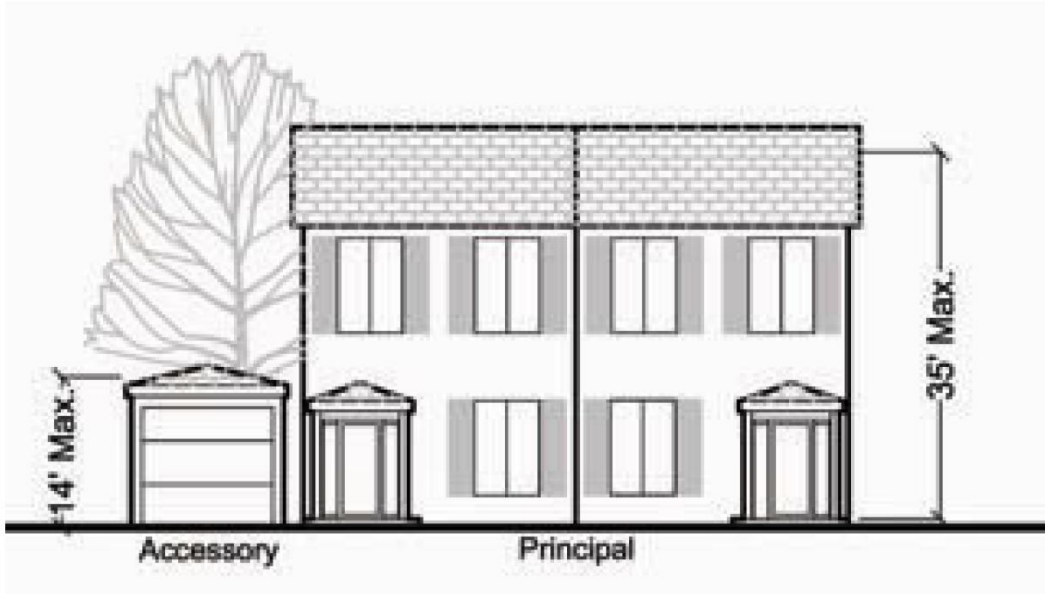

MT. LEBANON CODE

NO SCALE

C1 - RESIDENTIAL

DIAGRAM 46

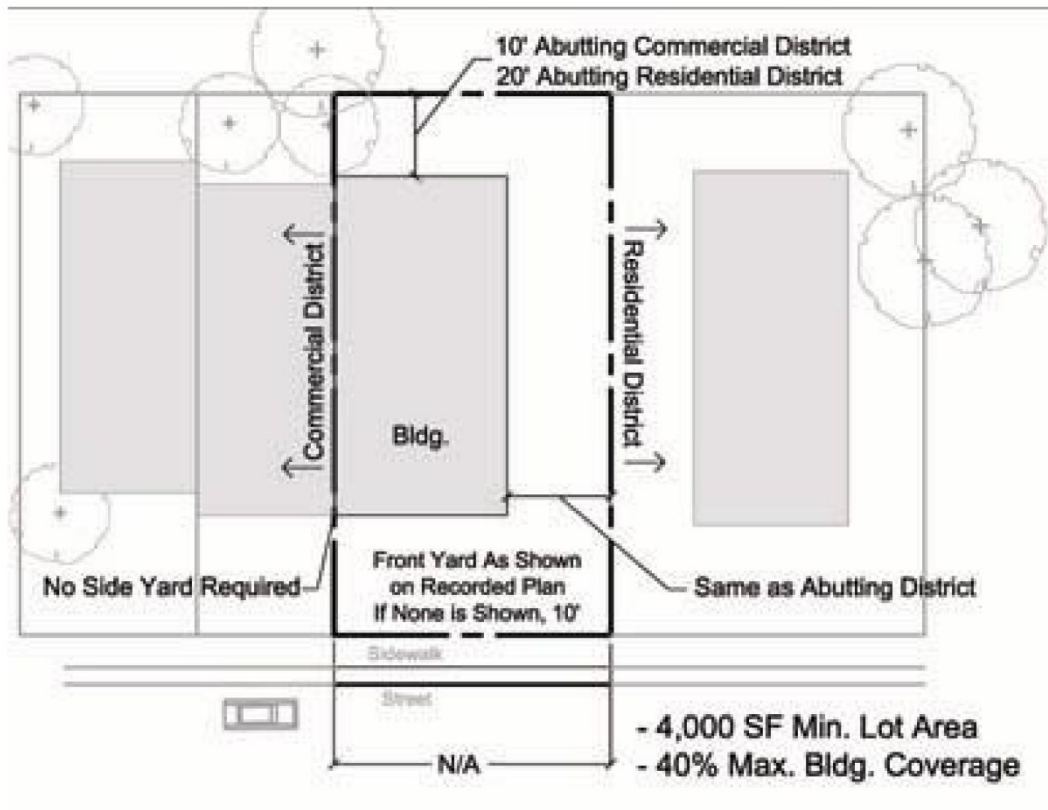

ZONING

NO SCALE

C1 – RESIDENTIAL

DIAGRAM 47

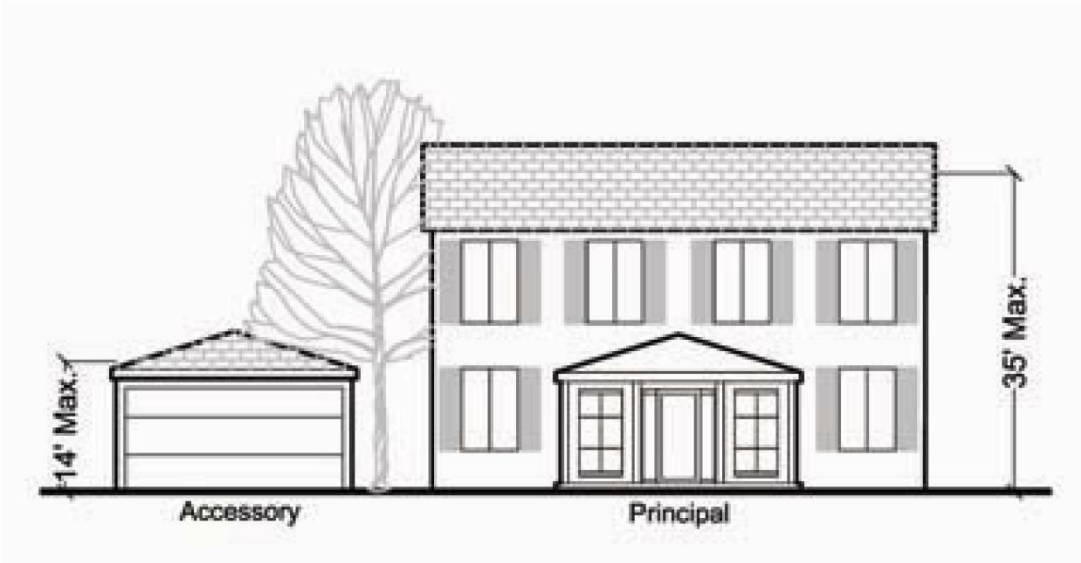

MT. LEBANON CODE

NO SCALE

R1 - RESIDENTIAL

DIAGRAM 48

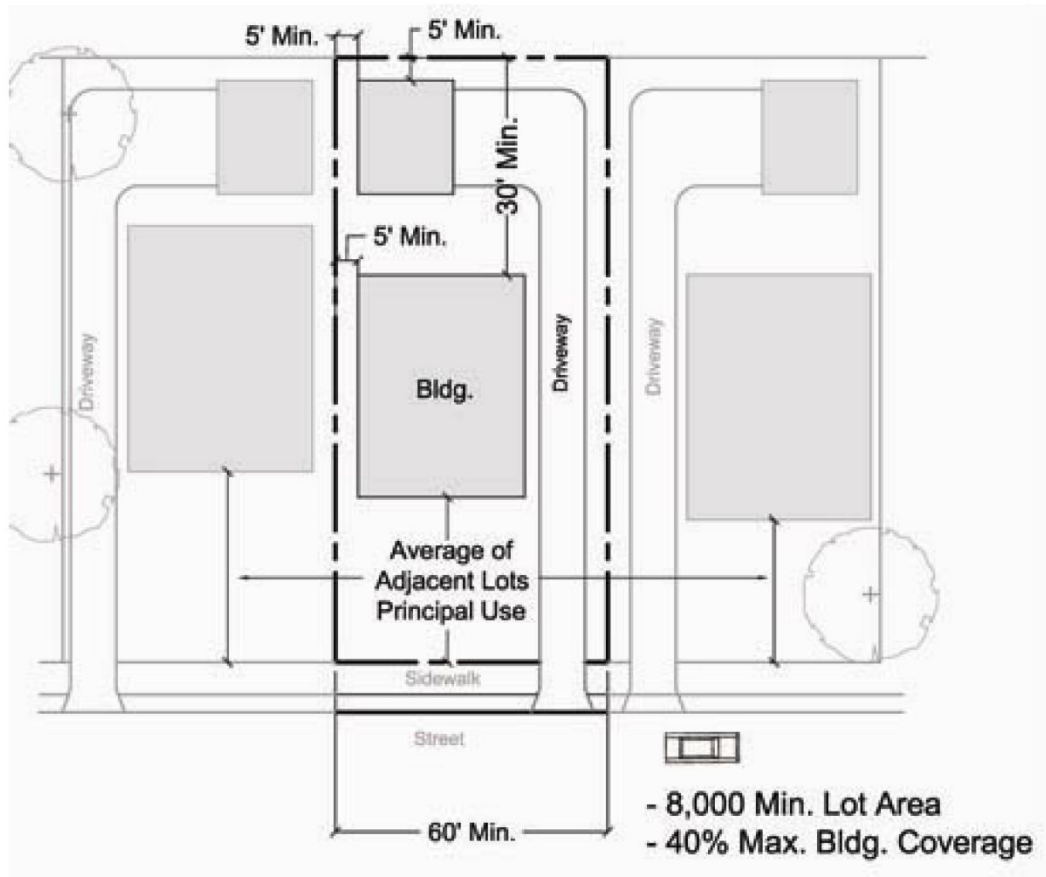

ZONING

NO SCALE

R1 - RESIDENTIAL

DIAGRAM 49

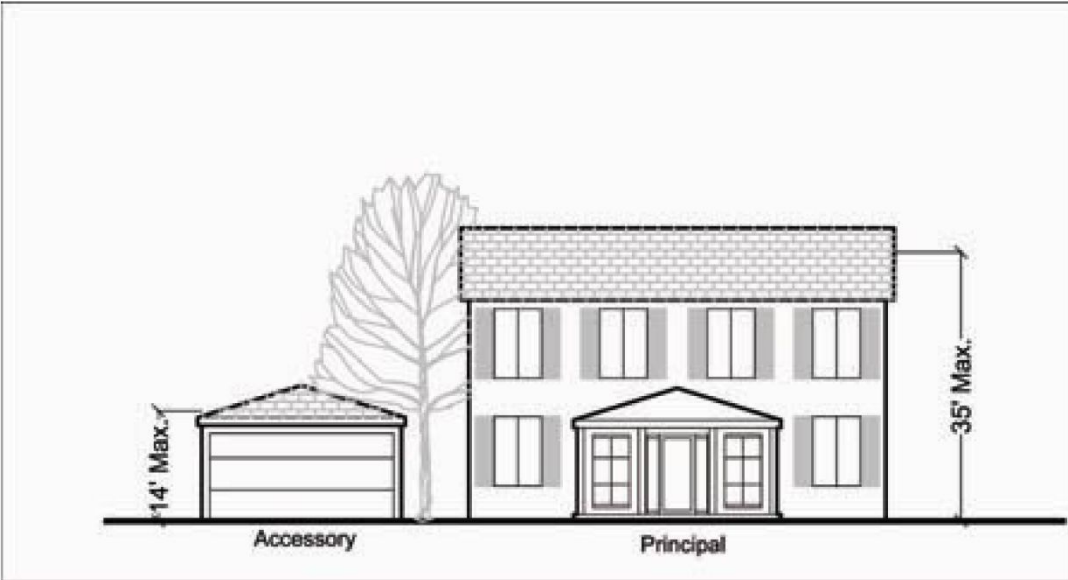

MT. LEBANON CODE

NO SCALE

R2 - RESIDENTIAL

DIAGRAM 50

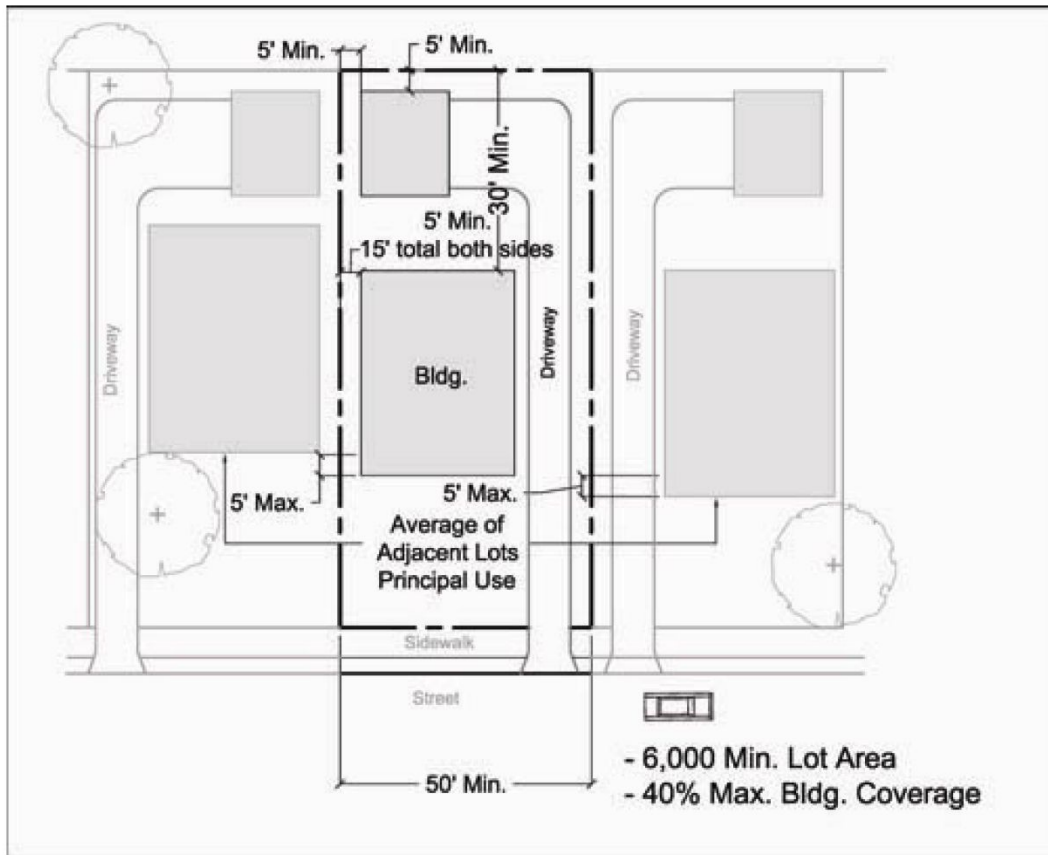

ZONING

NO SCALE

R3 – RESIDENTIAL DETACHED

DIAGRAM 51

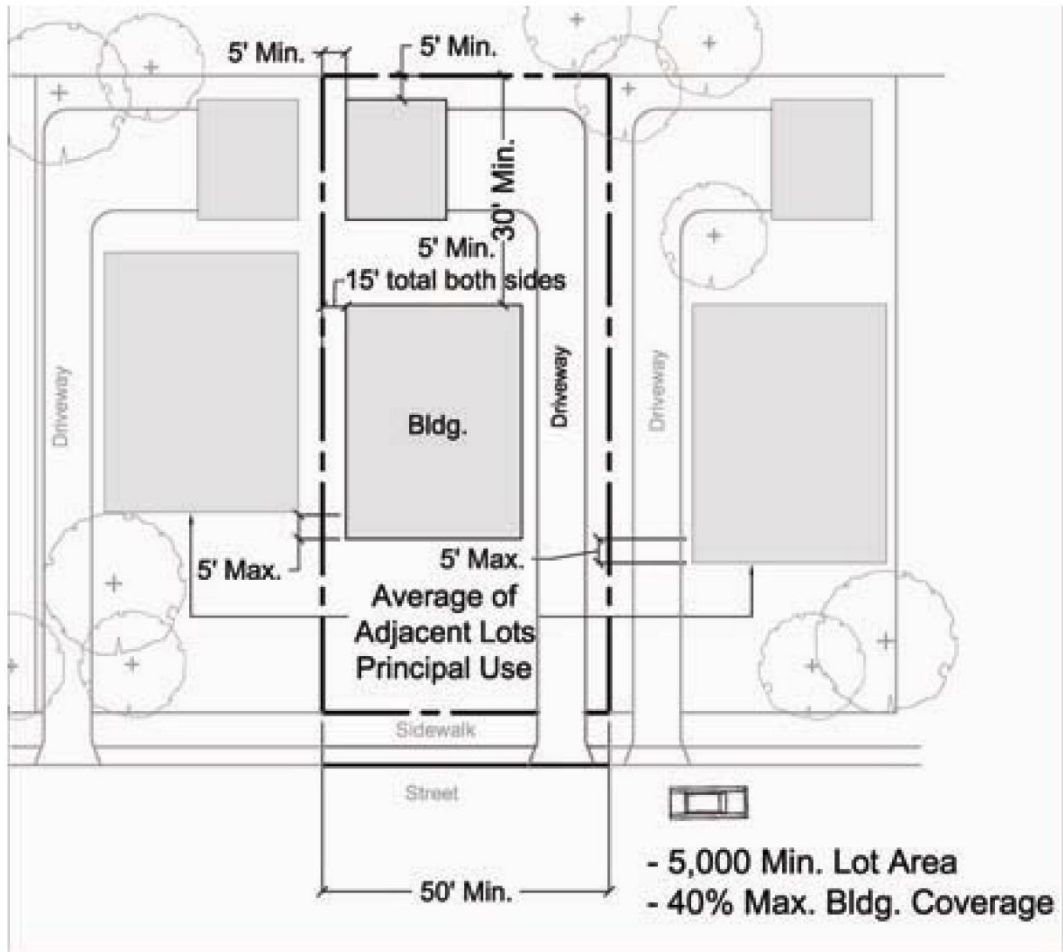

MT. LEBANON CODE

NO SCALE

R3 – RESIDENTIAL ATTACHED

DIAGRAM 52

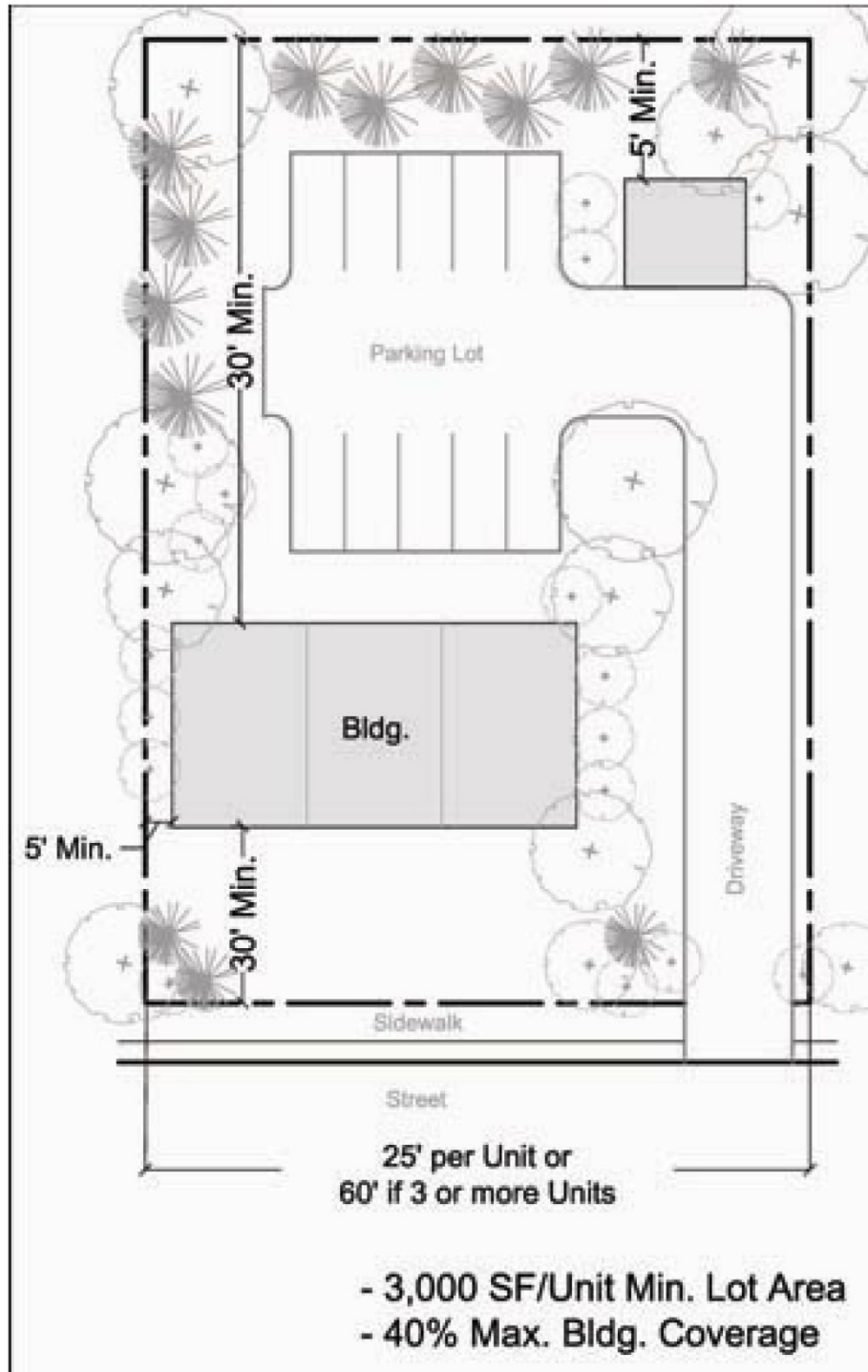

ZONING

NO SCALE

R4 – RESIDENTIAL MULTI - FAMILY

DIAGRAM 53

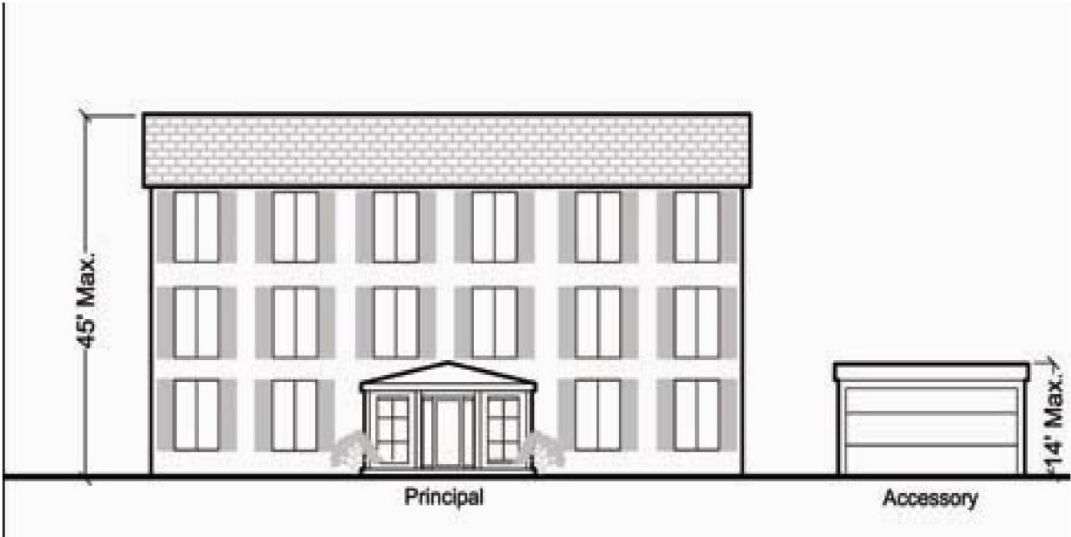

MT. LEBANON CODE

NO SCALE

R4 – Residential Multi - Family

Diagram 54

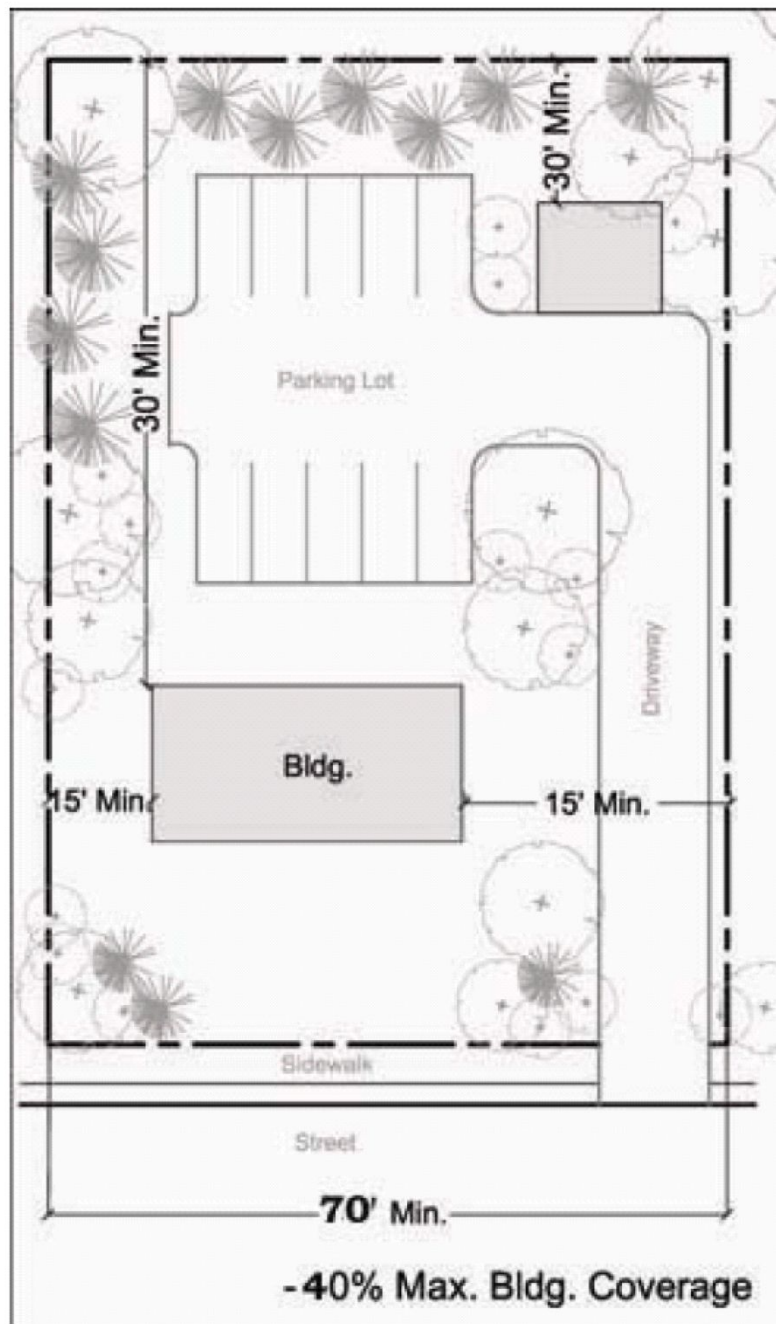

ZONING

NO SCALE

R5 - RESIDENTIAL

DIAGRAM 55



MT. LEBANON CODE

NO SCALE

R5 - RESIDENTIAL

DIAGRAM 56

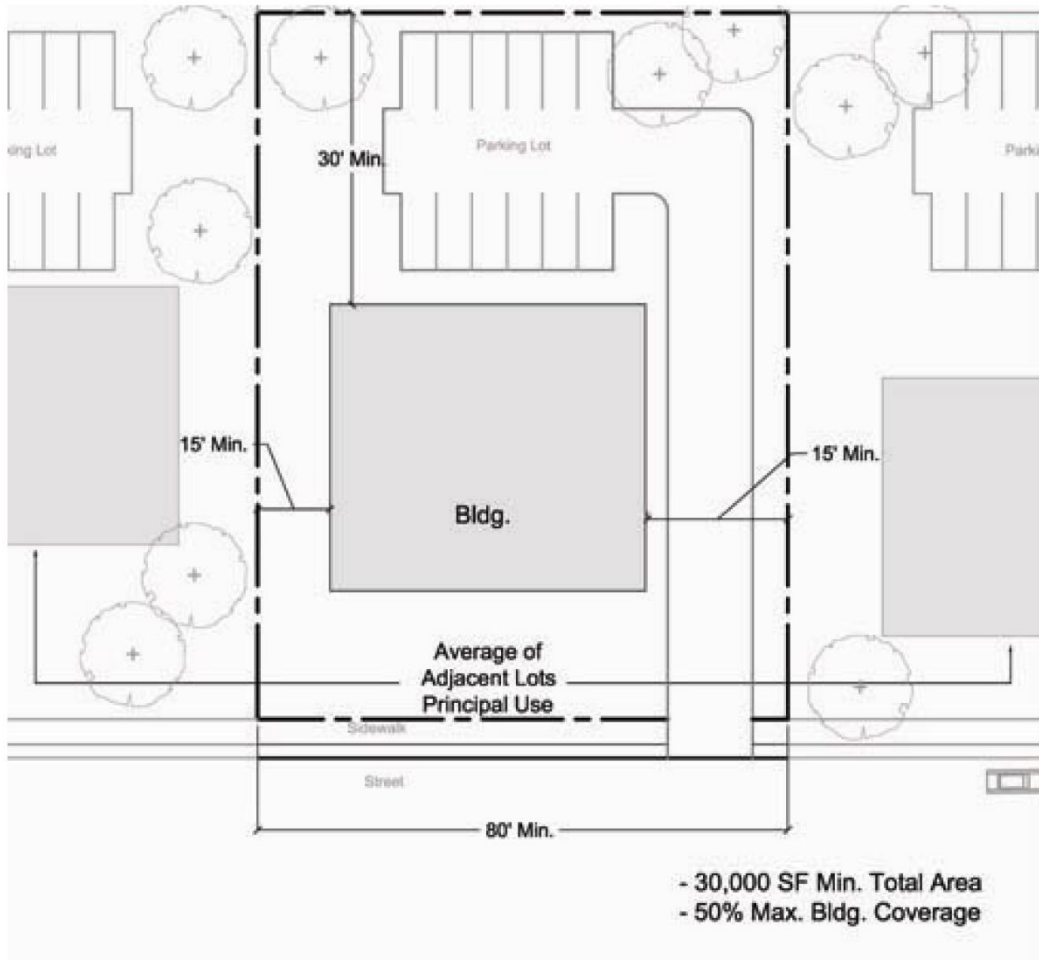

ZONING

NO SCALE

PARALLEL PARKING
ALL DISTRICTS

DIAGRAM 57

