

ORDINANCE NO. 02-02-2025

AN ORDINANCE AMENDING SANTAQUIN CITY CODE TO ADOPT SETBACK TABLES AND UPDATE SETBACK FIGURES PROVIDING FOR CODIFICATION, CORRECTION OF SCRIVENER'S ERRORS, SEVERABILITY, AND AN EFFECTIVE DATE FOR THE ORDINANCE.

WHEREAS, the City of Santaquin is a fourth-class city of the state of Utah; and

WHEREAS, the State Legislature has granted general welfare power to the City Council, independent, apart from, and in addition to, its specific grants of legislative authority, which enables the city to pass ordinances which are reasonably and appropriately related to the objectives of that power, i.e. providing for the public safety, health, and welfare; and

WHEREAS, the City Council desires to amend Santaquin City Code Title 10 Chapter 20 Sections 70, 80, 90, 100, 110, 130, 150, 180, 190, 220, 240 to adopt setbacks tables and update setback figures and Title 10 Chapter 52 Section 30 to simplify landscaping setback requirements.

WHEREAS, the Santaquin City Planning Commission held a public hearing on January 28, 2025, which hearing was preceded by the posting of public notice in at least three public places within the City limits of Santaquin City; and

WHEREAS, after the noted public hearing, the Santaquin City Planning Commission forwarded a recommendation to the City Council;

NOW, THEREFORE, BE IT ORDAINED by the City Council of Santaquin City, State of Utah, as follows:

Section I. Amendments

Title 10 Chapter 20 Section 70 is amended as follows: (underlined text is added)

10.20.070 R-8 RESIDENTIAL ZONE

E. Location Requirements:

1. ~~Dwellings And Other Main Buildings: Dwellings and other main buildings on interior and corner lots shall comply with the following setback requirements. Unless specifically stated, the following setbacks are intended to create a building envelope and are not necessarily connected to building orientation:~~
 - a. ~~Front Setback:~~
 - (1) ~~To living area or garage side: Twenty feet (20') from the front lot line(s).~~
 - (2) ~~To garage doors: Twenty five feet (25') from the front lot line(s).~~
 - (3) ~~To covered porches: Fifteen feet (15') from the front lot line(s).~~
 - b. ~~Side Setback: Eight feet (8') from side property line.~~
 - c. ~~Rear Setback: Twenty five feet (25') from rear property line.~~
 - d. ~~Setback Modification: A property which fronts onto an urban or multiuse, nonequestrian trail corridor, as shown in the adopted Parks, Recreation and~~

~~Open Space Master Plan, may reduce the front setback along such corridor. The setback reduction may not exceed the width of such corridor, as measured from back of curb, and a minimum ten-foot (10') setback must be maintained. The modification must still provide for twenty four feet (24') of parking between the structure and the lot line. (Ord. 5-05-2015, 5-6-2015, eff. 5-7-2015)~~

- ~~2. Accessory Structures (Including Detached Garages):~~
~~3. Clear View: All structures must be placed in conformance with the clear view standards found in SCC 10.16.090. (Ord. 03-02-2006, 3-1-2006, eff. 3-2-2006; amd. Ord. 07-01-2011, 7-27-2011, eff. 7-28-2011)~~

1. Setbacks

R-8 Setback Requirements				
	Front	Street Side	Side	Rear
Main Building	To living area 20' ¹ , garage doors 25' ¹ , covered porches 15' ¹	20'	8'	25'
Nonresidential Use Parking	20'	20'	5'	5'
Accessory Structure	Not permitted	20' ²	8' ³	10' ³
Accessory Structures shall be located at least twelve feet (12') from the dwelling or main structure and shall not be in any utility easements without written consent from those affected entities.				

Notes

1. A property that fronts onto an urban or multiuse, non-equestrian trail corridor, as shown in the adopted Parks, Recreation, and Open Space Master Plan, may reduce the front setback along such corridor. The setback reduction may not exceed the width of such corridor, as measured from the back of curb, and a minimum ten-foot (10') setback must be maintained. The modification must still provide twenty-four feet (24') of parking between the structure and the lot line.
 2. A three-foot (3') setback along the secondary frontage shall be permitted for an accessory building less than two hundred (200) square feet.
 3. A three-foot (3') side or rear setback shall be permitted for accessory buildings if the accessory structure walls closest to the side or rear property line are constructed with one hour or more fire-resistant walls.
2. Clear View: All structures must be placed in conformance with the clear view standards found in SCC 10.16.090. (Ord. 03-02-2006, 3-1-2006, eff. 3-2-2006; amd. Ord. 07-01-2011, 7-27-2011, eff. 7-28-2011)
- F. Dwelling Size: Minimum dwelling size shall be one thousand (1,000) square feet floor area on the main floor. (Ord. 2-01-2002, 2-5-2002, eff. 2-5-2002; amd. Ord. 07-01-2011, 7-27-2011, eff. 7-28-2011)
- G. Parking And Access Standards: Each dwelling is required to have a minimum of two (2) parking spaces per dwelling unit located on the property unless otherwise specified. (Ord. 10-01-2014, 10-1-2014, eff. 10-2-2014)
- H. Property Development Standards:

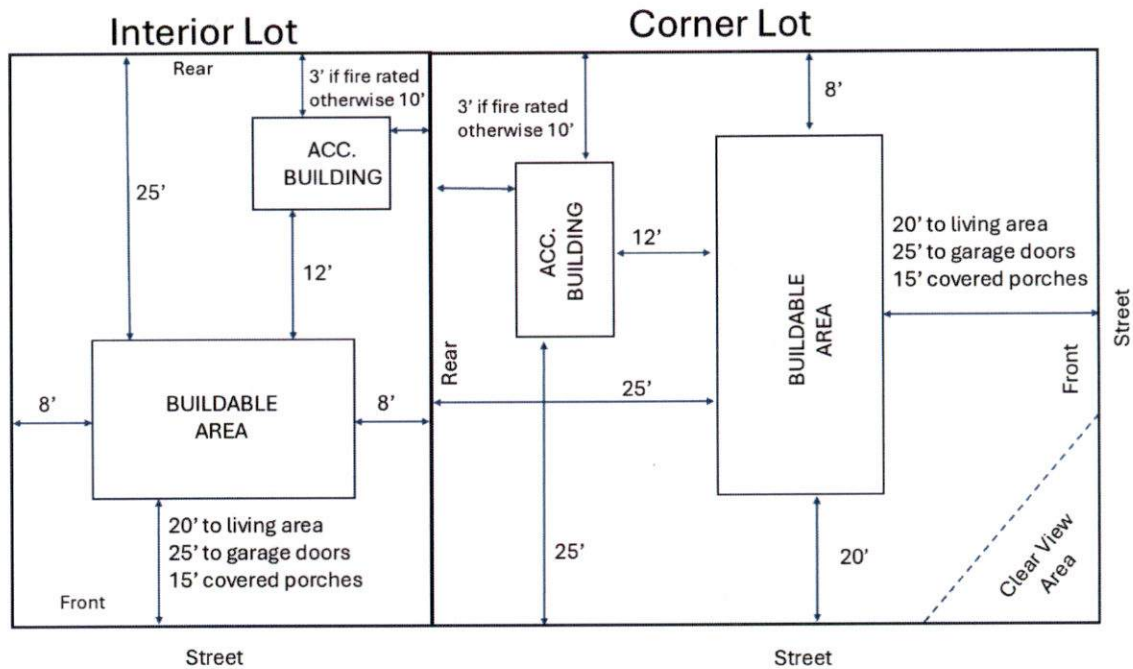

Title 10 Chapter 20 Section 80 is amended as follows: (underlined text is added)

10.20.080 R-10 RESIDENTIAL ZONE

E. Location Requirements:

1. Dwellings And Other Main Buildings:

- a. Front Setback: Thirty feet (30') from the front lot line.
- b. Front Setback On Corner Lot: Thirty feet (30') from property line along primary frontage, twenty five feet (25') from property line along secondary frontage.
- c. Side Setback: Ten feet (10') from side property line.
- d. Rear Setback: Twenty five feet (25') from rear property line.
- e. Setback Modification: A property which fronts onto an urban or multiuse, nonequestrian trail corridor, as shown in the adopted Parks, Recreation and Open Space Master Plan, may reduce the front setback along such corridor. The setback reduction may not exceed the width of such corridor, as measured from back of curb, and a minimum ten foot (10') setback must be maintained. The modification must still provide for twenty four feet (24') of parking between the structure and the lot line. (Ord. 5-05-2015, 5-6-2015, eff. 5-7-2015)

2. Accessory Structures (Including Detached Garages):

- a. General Setbacks: All accessory structures must be located at least twelve feet (12') from any associated dwelling or main structure and may not be located in any utility easements without written consent from those affected entities.
- b. Front Setback: Accessory structures are not permitted in the front yard of a dwelling.
- c. Front Setback On Corner Lot: Accessory structures are not permitted in the front yard of a dwelling along a primary frontage nor within twenty five feet

(25') from secondary frontages except that accessory structures that are less than two hundred (200) square feet may be within the setback from a secondary frontage if the accessory structure is located at least three feet (3') from the property line that is along a secondary frontage.

d. ~~Side Setback: Accessory structures must be ten feet (10') from a side property line, except that a three foot (3') side setback shall be permitted if the accessory structure walls closest to the side property line are constructed with one hour or more fire resistant walls.~~

e. ~~Rear Setback: Accessory structures must be ten feet (10') from the rear property line, except that a three foot (3') rear setback shall be permitted if the accessory structure walls closest to the rear property line are constructed with one hour or more fire resistant walls. (Ord. 02-03-2018, 4-4-2018, eff. 4-5-2018)~~

3. ~~Clear View: All structures must be placed in conformance with the clear view standards found in SCC 10.16.090. (Ord. 03-02-2006, 3-1-2006, eff. 3-2-2006; amd. Ord. 07-01-2011, 7-27-2011, eff. 7-28-2011)~~

1. Setbacks

R-10 Setback Requirements				
	Front	Street Side	Side	Rear
<u>Building</u>	<u>30'¹</u>	<u>25'</u>	<u>10'</u>	<u>25'</u>
<u>Nonresidential Use Parking</u>	<u>20'</u>	<u>20'</u>	<u>5'</u>	<u>5'</u>
<u>Accessory Structure</u>	<u>Not permitted</u>	<u>25'²</u>	<u>10'³</u>	<u>10'³</u>
<u>Accessory Structures shall be located at least twelve feet (12') from the dwelling or main structure and shall not be in any utility easements without written consent from those affected entities.</u>				

Notes

1. A property that fronts onto an urban or multiuse, non-equestrian trail corridor, as shown in the adopted Parks, Recreation, and Open Space Master Plan, may reduce the front setback along such corridor. The setback reduction may not exceed the width of such corridor, as measured from the back of curb, and a minimum ten-foot (10') setback must be maintained. The modification must still provide twenty-four feet (24') of parking between the structure and the lot line.
2. A three-foot (3') setback along the secondary frontage shall be permitted for an accessory building less than two hundred (200) square feet.
3. A three-foot (3') side or rear setback shall be permitted for accessory buildings if the accessory structure walls closest to the side or rear property line are constructed with one hour or more fire-resistant walls.

2. Clear View: All structures must be placed in conformance with the clear view standards found in SCC 10.16.090. (Ord. 03-02-2006, 3-1-2006, eff. 3-2-2006; amd. Ord. 07-01-2011, 7-27-2011, eff. 7-28-2011)

F. Dwelling Size: Minimum dwelling size shall be nine hundred (900) square feet floor area on the main floor. (Ord. 2-01-2002, 2-5-2002, eff. 2-5-2002; amd. Ord. 07-01-2011, 7-27-2011, eff. 7-28-2011)

G. Property Development Standards:

~~Zoning Requirements: R-10 Property Development Standards~~

~~Residential Lots: Interior And Corner Lots~~

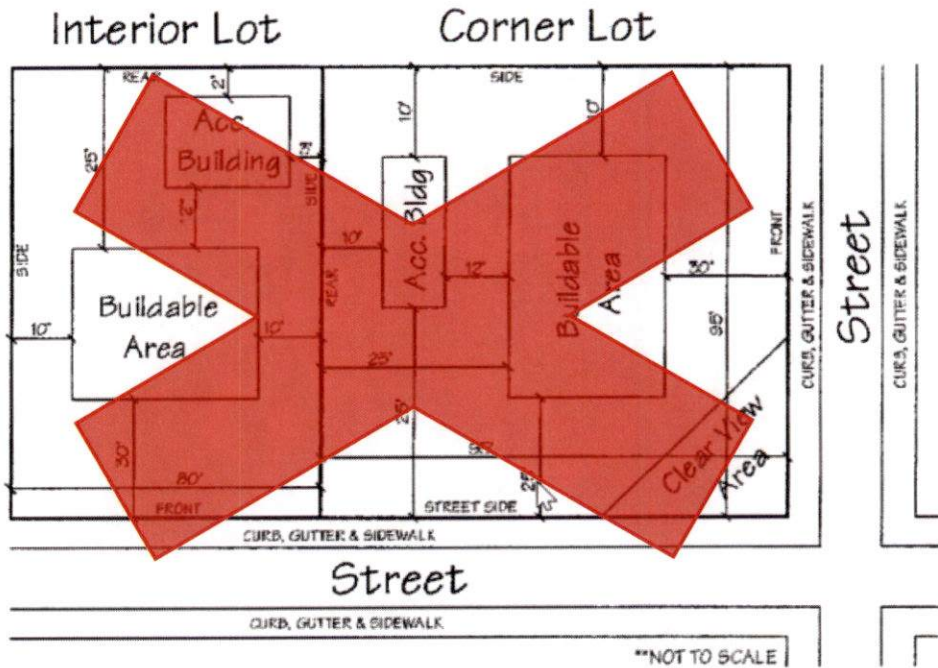

- All setbacks and lot dimensions are minimums unless otherwise noted.
- Property lines shown are in accordance with the Santaquin City construction standards and details and are usually not located at the back of the sidewalk.
- Minimum lot area: 9,600 square feet.
- Accessory building setbacks may be reduced, as shown on the typical lot above, as outlined in this code.
- Minimum dwelling size: 900 square feet.
- Clear view area: The size, location and regulation of the clear view area of corner lots are determined according to SCC 10.16.090 and do not necessarily reflect the representation in the diagram above.
- *Accessory building setback measured to the closest point of the primary structure.

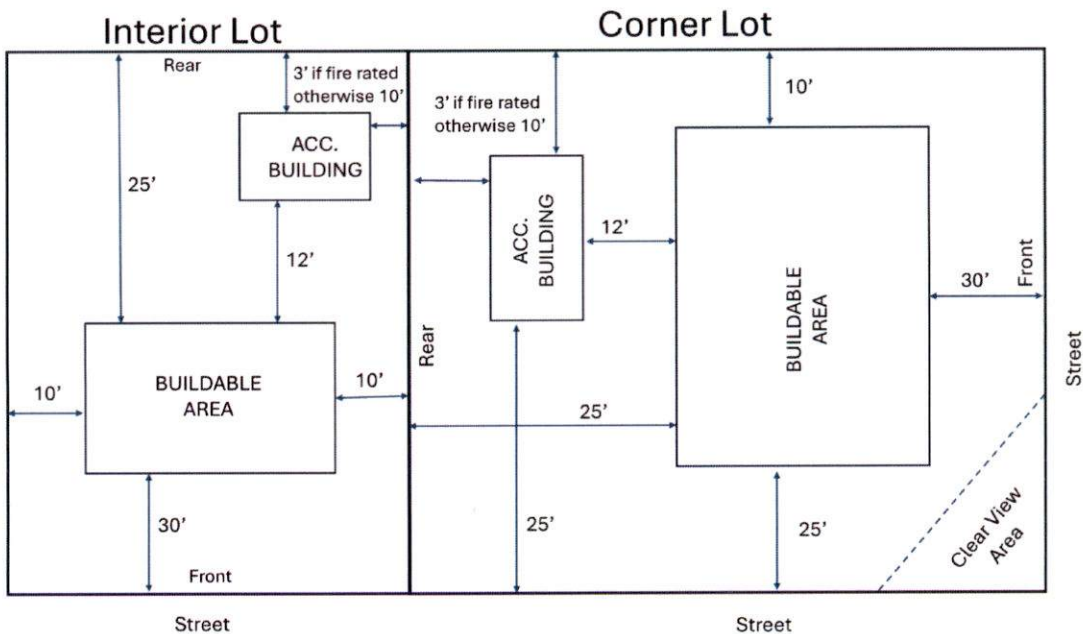

(Ord. 4-02-2005, 4-20-2005, eff. 4-21-2005; amd. Ord. 07-01-2011, 7-27-2011, eff. 7-28-2011)

Title 10 Chapter 20 Section 90 is amended as follows: (underlined text is added)

10.20.090 R-12 RESIDENTIAL ZONE

E. Location Requirements:

~~1. Dwellings And Other Main Buildings:~~

- ~~a. Front Setback: Thirty feet (30') from the front lot line.~~
- ~~b. Front Setback On Corner Lot: Thirty feet (30') from property line along primary frontage, twenty five feet (25') from property line along secondary frontage.~~
- ~~c. Side Setback: Ten feet (10') from side property line.~~
- ~~d. Rear Setback: Twenty five feet (25') from rear property line.~~
- ~~e. Setback Modification: A property which fronts onto an urban or multiuse, nonequestrian trail corridor, as shown in the adopted Parks, Recreation and Open Space Master Plan, may reduce the front setback along such corridor. The setback reduction may not exceed the width of such corridor, as measured from back of curb, and a minimum ten foot (10') setback must be maintained. The modification must still provide for twenty four feet (24') of parking between the structure and the lot line. (Ord. 5-05-2015, 5-6-2015, eff. 5-7-2015)~~

~~2. Accessory Structures (Including Detached Garages):~~

- ~~a. General Setbacks: All accessory structures must be located at least twelve feet (12') from any associated dwelling or main structure and may not be located in any utility easements without written consent from those affected entities.~~
- ~~b. Front Setback: Accessory structures are not permitted in the front yard of a dwelling.~~
- ~~c. Front Setback On Corner Lot: Accessory structures are not permitted in the front yard of a dwelling along a primary frontage nor within twenty five feet (25') from secondary frontages except that accessory structures that are less than two hundred (200) square feet may be within the setback from a secondary frontage if the accessory structure is located at least three feet (3') from the property line that is along a secondary frontage.~~
- ~~d. Side Setback: Accessory structures must be ten feet (10') from a side property line, except that a three foot (3') side setback shall be permitted if the accessory structure walls closest to the side property line are constructed with one hour or more fire resistant walls.~~
- ~~e. Rear Setback: Accessory structures must be ten feet (10') from the rear property line, except that a three foot (3') rear setback shall be permitted if the accessory structure walls closest to the rear property line are constructed with one hour or more fire resistant walls. (Ord. 02-03-2018, 4-4-2018, eff. 4-5-2018)~~

~~3. Clear View: All structures must be placed in conformance with the clear view standards found in SCC 10.16.090. (Ord. 03-02-2006, 3-1-2006, eff. 3-2-2006; amd. Ord. 07-01-2011, 7-27-2011, eff. 7-28-2011)~~

1. Setbacks

<u>R-12 Setback Requirements</u>				
	<u>Front</u>	<u>Street Side</u>	<u>Side</u>	<u>Rear</u>
<u>Building</u>	<u>30'¹</u>	<u>25'</u>	<u>10'</u>	<u>25'</u>
<u>Nonresidential Use Parking</u>	<u>20'</u>	<u>20'</u>	<u>5'</u>	<u>5'</u>
<u>Accessory Structure</u>	<u>Not permitted</u>	<u>25'²</u>	<u>10'³</u>	<u>10'³</u>

Accessory Structures shall be located at least twelve feet (12') from the dwelling or main structure and shall not be in any utility easements without written consent from those affected entities.

Notes

1. A property that fronts onto an urban or multiuse, non-equestrian trail corridor, as shown in the adopted Parks, Recreation, and Open Space Master Plan, may reduce the front setback along such corridor. The setback reduction may not exceed the width of such corridor, as measured from the back of curb, and a minimum ten-foot (10') setback must be maintained. The modification must still provide twenty-four feet (24') of parking between the structure and the lot line.
 2. A three-foot (3') setback along the secondary frontage shall be permitted for an accessory building less than two hundred (200) square feet.
 3. A three-foot (3') side or rear setback shall be permitted for accessory buildings if the accessory structure walls closest to the side or rear property line are constructed with one hour or more fire-resistant walls.
2. Clear View: All structures must be placed in conformance with the clear view standards found in SCC 10.16.090. (Ord. 03-02-2006, 3-1-2006, eff. 3-2-2006; amd. Ord. 07-01-2011, 7-27-2011, eff. 7-28-2011)
- F. Dwelling Size: Minimum dwelling size shall be one thousand (1,000) square feet floor area on the main floor. (Ord. 2-01-2002, 2-5-2002, eff. 2-5-2002; amd. Ord. 07-01-2011, 7-27-2011, eff. 7-28-2011)
- G. Property Development Standards:
Zoning Requirements: R-12 Property Development Standards
Residential Lots: Interior And Corner Lots

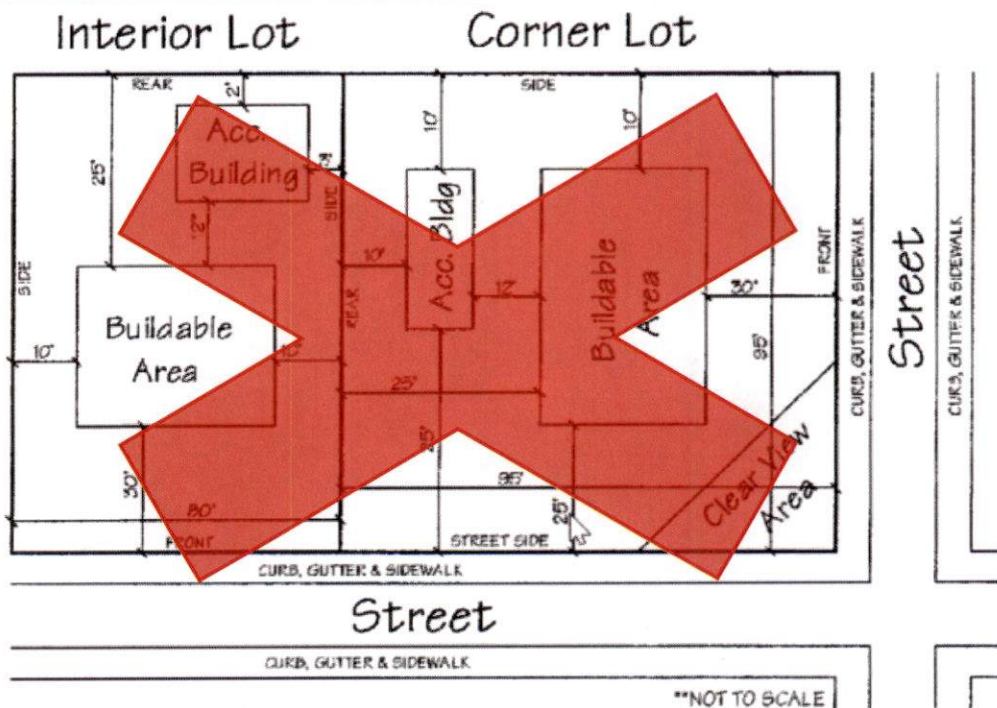

- All setbacks and lot dimensions are minimums unless otherwise noted.
- Property lines shown are in accordance with the Santaquin City construction standards and details and are usually not located at the back of the sidewalk.
- Minimum lot area: 12,000 square feet (13,225 square feet for corner lots).

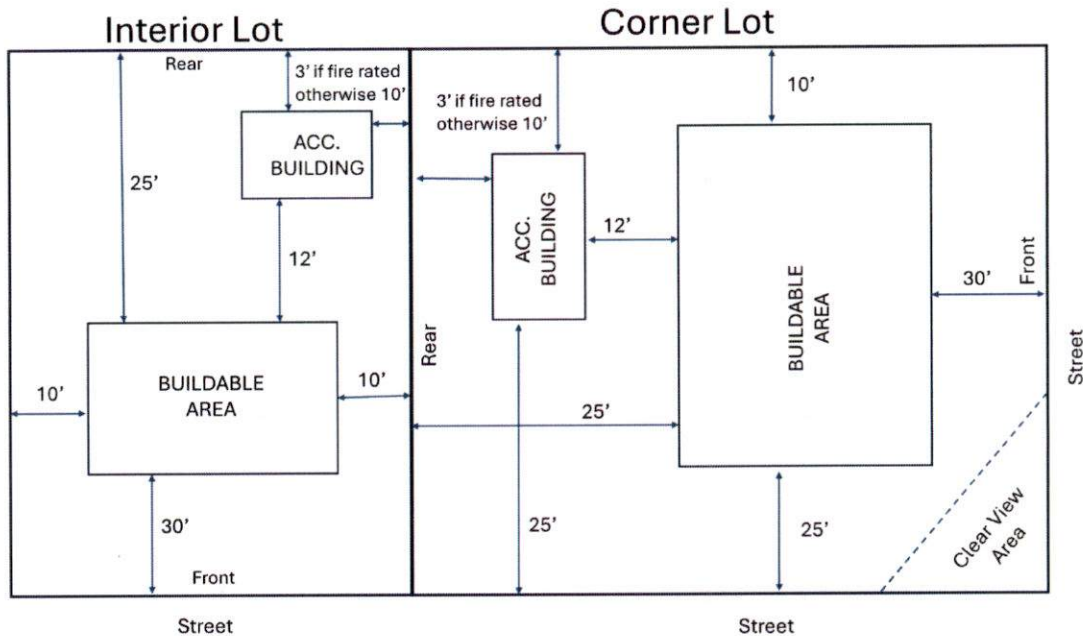

-Accessory building setbacks may be reduced, as shown on the typical lot above, as outlined in this code.

-Minimum dwelling size: 1,000 square feet.

-Clear view area: The size, location and regulation of the clear view area of corner lots are determined according to SCC 10.16.090 and do not necessarily reflect the representation in the diagram above.

*Accessory building setback measured to the closest point of the primary structure.

(Ord. 4-02-2005, 4-20-2005, eff. 4-21-2005; amd. Ord. 07-01-2011, 7-27-2011, eff. 7-28-2011)

Title 10 Chapter 20 Section 100 is amended as follows: (underlined text is added)

10.20.100 R-15 RESIDENTIAL ZONE

E. Location Requirements:

1.—Dwellings And Other Main Buildings:

- a.—Front Setback: Thirty feet (30') from the front lot line.
- b.—Front Setback On Corner Lot: Thirty feet (30') from property line along primary frontage, twenty five feet (25') from property line along secondary frontage.
- c.—Side Setback: Ten feet (10') from side property line.
- d.—Rear Setback: Twenty five feet (25') from rear property line.
- e.—Setback Modification: A property which fronts onto an urban or multiuse, nonequestrian trail corridor, as shown in the adopted Parks, Recreation and Open Space Master Plan, may reduce the front setback along such corridor. The setback reduction may not exceed the width of such corridor, as measured from back of curb, and a minimum ten foot (10') setback must be maintained. The modification must still provide for twenty four feet (24') of parking between the structure and the lot line. (Ord. 5-05-2015, 5-6-2015, eff. 5-7-2015)

2.—Accessory Structures (Including Detached Garages):

- a. ~~General Setbacks: All accessory structures must be located at least twelve feet (12') from any associated dwelling or main structure and may not be located in any utility easements without written consent from those affected entities.~~
 - b. ~~Front Setback: Accessory structures are not permitted in the front yard of a dwelling.~~
 - c. ~~Front Setback On Corner Lot: Accessory structures are not permitted in the front yard of a dwelling along a primary frontage nor within twenty five feet (25') from secondary frontages except that accessory structures that are less than two hundred (200) square feet may be within the setback from a secondary frontage if the accessory structure is located at least three feet (3') from the property line that is along a secondary frontage.~~
 - d. ~~Side Setback: Accessory structures must be ten feet (10') from a side property line, except that a three foot (3') side setback shall be permitted if the accessory structure walls closest to the side property line are constructed with one hour or more fire resistant walls.~~
 - e. ~~Rear Setback: Accessory structures must be ten feet (10') from the rear property line, except that a three foot (3') rear setback shall be permitted if the accessory structure walls closest to the rear property line are constructed with one hour or more fire resistant walls. (Ord. 02-03-2018, 4-4-2018, eff. 4-5-2018)~~
3. ~~Clear View: All structures must be placed in conformance with the clear view standards found in SCC 10.16.090. (Ord. 03-02-2006, 3-1-2006, eff. 3-2-2006; amd. Ord. 07-01-2011, 7-27-2011, eff. 7-28-2011)~~

1. Setback

<u>R-15 Setback Requirements</u>				
	<u>Front</u>	<u>Street Side</u>	<u>Side</u>	<u>Rear</u>
<u>Building</u>	<u>30'¹¹</u>	<u>25'</u>	<u>10'</u>	<u>25'</u>
<u>Nonresidential Use Parking</u>	<u>20'</u>	<u>20'</u>	<u>5'</u>	<u>5'</u>
<u>Accessory Structure</u>	<u>Not permitted</u>	<u>25'¹²</u>	<u>10'¹³</u>	<u>10'¹³</u>
<u>Accessory Structures shall be located at least twelve feet (12') from the dwelling or main structure and shall not be in any utility easements without written consent from those affected entities.</u>				

Notes

1. A property that fronts onto an urban or multiuse, non-equestrian trail corridor, as shown in the adopted Parks, Recreation, and Open Space Master Plan, may reduce the front setback along such corridor. The setback reduction may not exceed the width of such corridor, as measured from the back of curb, and a minimum ten-foot (10') setback must be maintained. The modification must still provide twenty-four feet (24') of parking between the structure and the lot line
 2. A three-foot (3') setback along the secondary frontage shall be permitted for an accessory building less than two hundred (200) square feet.
 3. A three-foot (3') side or rear setback shall be permitted for accessory buildings if the accessory structure walls closest to the side or rear property line are constructed with one hour or more fire-resistant walls.
2. Clear View: All structures must be placed in conformance with the clear view standards found in SCC 10.16.090. (Ord. 03-02-2006, 3-1-2006, eff. 3-2-2006; amd. Ord. 07-01-2011, 7-27-2011, eff. 7-28-2011)
- F. Dwelling Size: Minimum dwelling size shall be one thousand (1,000) square feet floor area on the main floor. (Ord. 2-01-2002, 2-5-2002, eff. 2-5-2002; amd. Ord. 07-01-2011, 7-27-2011, eff. 7-28-2011)
- G. Property Development Standards:

Zoning Requirements: R-15 Property Development Standards
 Residential Lots: Interior And Corner Lots

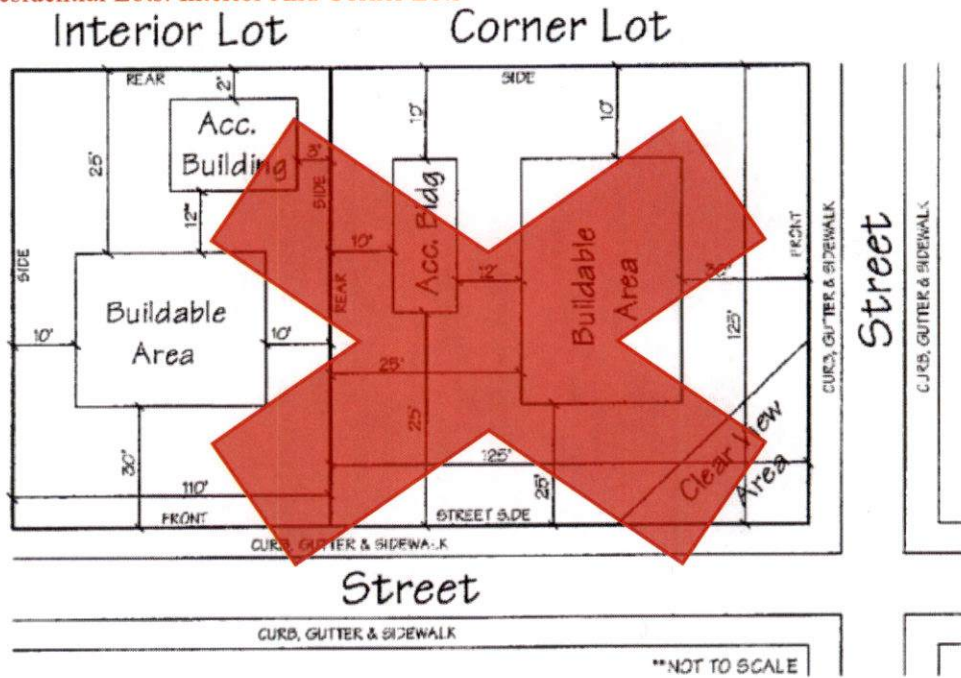

- All setbacks and lot dimensions are minimums unless otherwise noted.
- Property lines shown are in accordance with the Santaquin City construction standards and details and are usually not located at the back of the sidewalk.
- Minimum lot area: 15,000 square feet (15,625 square feet for corner lots).
- Accessory building setbacks may be reduced, as shown on the typical lot above, as outlined in this code.
- Minimum dwelling size: 1,000 square feet.
- Clear view area: The size, location and regulation of the clear view area of corner lots are determined according to SCC 10.16.090 and do not necessarily reflect the representation in the diagram above.
- *Accessory building setback measured to the closest point of the primary structure.

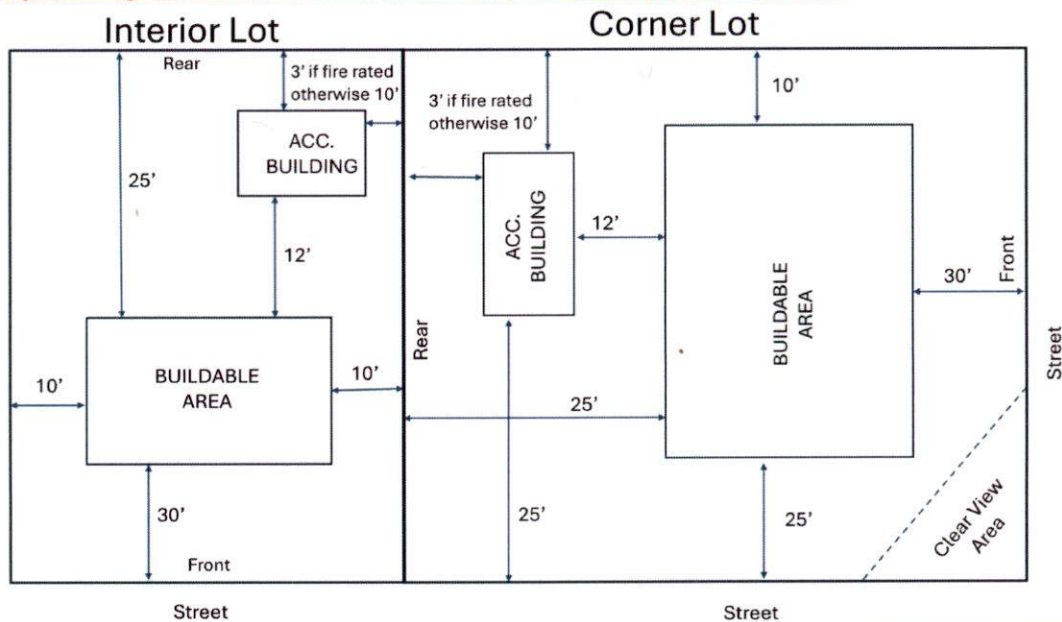

Title 10 Chapter 20 Section 110 is amended as follows: (underlined text is added)

10.20.110 R-20 RESIDENTIAL ZONE

E. Location Requirements:

- ~~1. Dwellings And Other Main Buildings:

 - a. Front Setback: Thirty feet (30') from the front lot line.
 - b. Front Setback On Corner Lot: Thirty feet (30') from property line along primary frontage, twenty five feet (25') from property line along secondary frontage.
 - c. Side Setback: Ten feet (10') from side property line.
 - d. Rear Setback: Twenty five feet (25') from rear property line.
 - e. Setback Modification: A property which fronts onto an urban or multiuse, nonequestrian trail corridor, as shown in the adopted Parks, Recreation and Open Space Master Plan, may reduce the front setback along such corridor. The setback reduction may not exceed the width of such corridor, as measured from back of curb, and a minimum ten foot (10') setback must be maintained. The modification must still provide for twenty four feet (24') of parking between the structure and the lot line. (Ord. 5-05-2015, 5-6-2015, eff. 5-7-2015)~~
- ~~2. Accessory Structures (Including Detached Garages):

 - a. General Setbacks: All accessory structures must be located at least twelve feet (12') from any associated dwelling or main structure and may not be located in any utility easements without written consent from those affected entities.
 - b. Front Setback: Accessory structures are not permitted in the front yard of a dwelling.
 - c. Front Setback On Corner Lot: Accessory structures are not permitted in the front yard of a dwelling along a primary frontage nor within twenty five feet (25') from secondary frontages except that accessory structures that are less than two hundred (200) square feet may be within the setback from a secondary frontage if the accessory structure is located at least three feet (3') from the property line that is along a secondary frontage.
 - d. Side Setback: Accessory structures must be ten feet (10') from a side property line, except that a three foot (3') side setback shall be permitted if the accessory structure walls closest to the side property line are constructed with one hour or more fire resistant walls.
 - e. Rear Setback: Accessory structures must be ten feet (10') from the rear property line, except that a three foot (3') rear setback shall be permitted if the accessory structure walls closest to the rear property line are constructed with one hour or more fire resistant walls. (Ord. 02-03-2018, 4-4-2018, eff. 4-5-2018)~~
- ~~3. Clear View: All structures must be placed in conformance with the clear view standards found in SCC 10.16.090. (Ord. 03-02-2006, 3-1-2006, eff. 3-2-2006; amd. Ord. 07-01-2011, 7-27-2011, eff. 7-28-2011)~~

1. Setbacks

<u>R-20 Setback Requirements</u>				
	<u>Front</u>	<u>Street Side</u>	<u>Side</u>	<u>Rear</u>
<u>Building</u>	<u>30'</u>	<u>25'</u>	<u>10'</u>	<u>25'</u>

<u>Nonresidential Use Parking</u>	<u>20'</u>	<u>20'</u>	<u>5'</u>	<u>5'</u>
<u>Accessory Structure</u>	<u>Not permitted</u>	<u>25'²</u>	<u>10'³</u>	<u>10'³</u>
<u>Accessory Structures shall be located at least twelve feet (12') from the dwelling or main structure and shall not be in any utility easements without written consent from those affected entities.</u>				

Notes

1. A property that fronts onto an urban or multiuse, non-equestrian trail corridor, as shown in the adopted Parks, Recreation, and Open Space Master Plan, may reduce the front setback along such corridor. The setback reduction may not exceed the width of such corridor, as measured from the back of curb, and a minimum ten-foot (10') setback must be maintained. The modification must still provide twenty-four feet (24') of parking between the structure and the lot line.
 2. A three-foot (3') setback along the secondary frontage shall be permitted for an accessory building less than two hundred (200) square feet.
 3. A three-foot (3') side or rear setback shall be permitted for accessory buildings if the accessory structure walls closest to the side or rear property line are constructed with one hour or more fire-resistant walls.
2. Clear View: All structures must be placed in conformance with the clear view standards found in SCC 10.16.090. (Ord. 03-02-2006, 3-1-2006, eff. 3-2-2006; amd. Ord. 07-01-2011, 7-27-2011, eff. 7-28-2011)
- F. Dwelling Size: Minimum dwelling size shall be one thousand two hundred (1,200) square feet floor area on the main floor. (Ord. 2-01-2002, 2-5-2002, eff. 2-5-2002; amd. Ord. 07-01-2011, 7-27-2011, eff. 7-28-2011)
- G. Property Development Standards:
Zoning Requirements: R-20 Property Development Standards
Residential Lots: Interior And Corner Lot

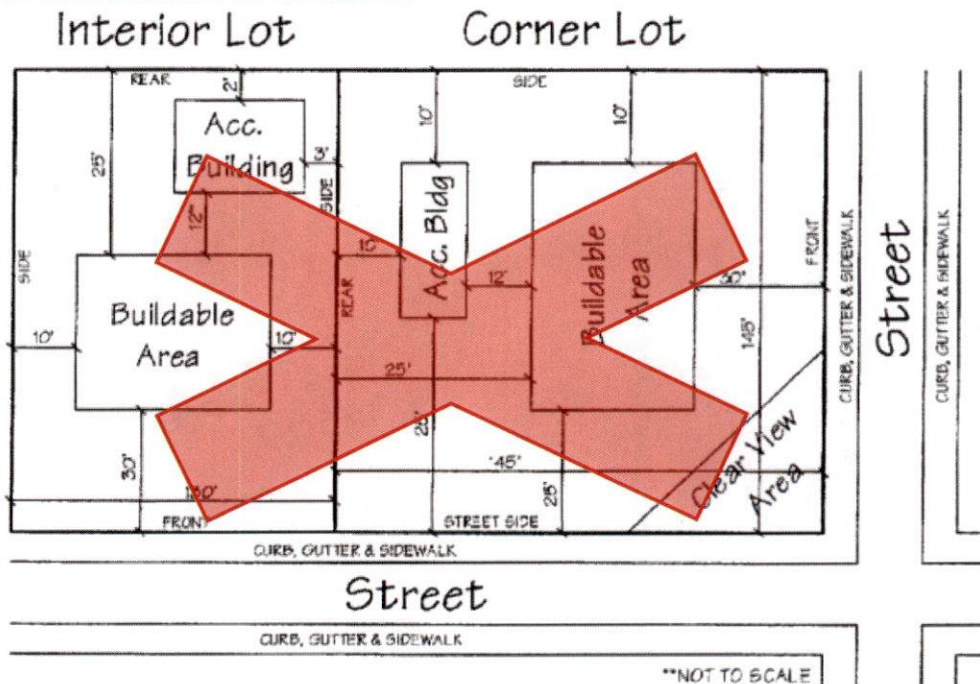

- All setbacks and lot dimensions are minimums unless otherwise noted.
- Property lines shown are in accordance with the Santaquin City construction standards and details and are usually not located at the back of the sidewalk.
- Minimum lot area: 20,000 square feet (21,025 square feet for corner lots).

-Accessory building setbacks may be reduced, as shown on the typical lot above, as outlined in this code.

-Minimum dwelling size: 1,200 square feet.

-Clear view area: The size, location and regulation of the clear view area of corner lots are determined according to SCC 10.16.090 and do not necessarily reflect the representation in the diagram above.

*Accessory building setback measured to the closest point of the primary structure.

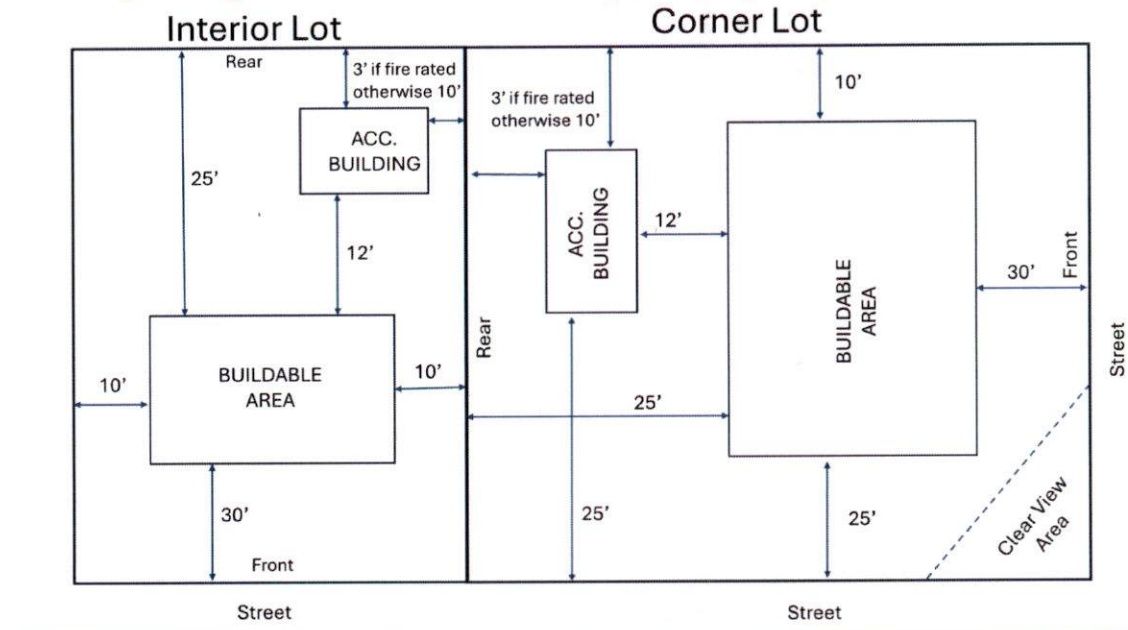

(Ord. 4-02-2005, 4-20-2005, eff. 4-21-2005; amd. Ord. 07-01-2011, 7-27-2011, eff. 7-28-2011)

Title 10 Chapter 20 Section 130 is amended as follows: (underlined text is added)

10.20.130 I-1 INDUSTRIAL ZONE

F. Location Requirements:

1.— **Front Setback:** All buildings and structures shall be set back at least thirty five feet (35') from the front lot line. (Ord. 2-01-2002, 2-5-2002, eff. 2-5-2002)

2.— **Side Setbacks:**

a.— **Interior Lots:** All main buildings shall be set back from the side property line a distance of at least ten feet (10'), and the sum of the total distance of the two (2) side setbacks shall be at least twenty feet (20'). Accessory buildings on interior lots shall be set back from the side property line a distance of at least ten feet (10'), except that a three foot (3') side setback shall be permitted for accessory buildings located at least twelve feet (12') to the rear of any main building and having fire resistant walls of two (2) hours or more.

b.— **Corner Lots:** All main and accessory buildings shall be set back from any street not less than twenty five feet (25'). Accessory buildings shall be set back not less than ten feet (10') from the interior side lot line, except that a three foot (3') interior side setback shall also be permitted for accessory buildings located a distance of twelve feet (12') from the rear of the primary structure and having fire resistant walls of two (2) hours or more.

3.— **Rear Setback:**

- a. ~~Interior Lots: All dwellings and other main buildings shall be set back from the rear property line a distance of at least ten feet (10'). Accessory buildings on interior lots shall be set back not less than ten feet (10') from the rear property line, except that a two foot (2') rear setback shall be permitted for accessory buildings having fire resistant walls of two (2) hours or more and located at least twelve feet (12') to the rear of any dwelling.~~
 - b. ~~Corner Lots: All dwellings and other main buildings shall be set back from the rear property line a distance of at least ten feet (10'). Accessory buildings on corner lots shall be set back not less than ten feet (10') from the rear property line, except that a two foot (2') rear setback shall be permitted for accessory buildings located at least twelve feet (12') to the rear of any dwelling and having fire resistant walls of two (2) hours or more. (Ord. 7-04-2002, 7-17-2002, eff. 7-23-2002)~~
4. ~~Clear View: All structures must be placed in conformance with the clear view standards found in SCC 10.16.090. (Ord. 11-03-2014, 11-5-2014, eff. 11-6-2014)~~

1. Setbacks

<u>I-1 Setback Requirements</u>				
	<u>Front</u>	<u>Street Side</u>	<u>Side³</u>	<u>Rear³</u>
<u>Building</u>	<u>35'</u>	<u>25'</u>	<u>10'</u>	<u>10'</u>
<u>Accessory Structure</u>	<u>35'</u>	<u>25'</u>	<u>10'¹</u>	<u>10'²</u>
<u>Parking</u>	<u>20'</u>	<u>20'</u>	<u>10'⁴</u>	<u>10'⁴</u>
<u>Accessory Structures shall be located at least twelve feet (12') from the dwelling or main structure and shall not be in any utility easements without written consent from those affected entities.</u>				

Notes:

- 1. A three-foot (3') side setback shall be permitted for accessory buildings located at least twelve feet (12') from the side or rear of any building and having fire resistant walls of two (2) hours or more.
 - 2. A two-foot (2') rear setback shall be permitted for accessory buildings located at least twelve feet (12') from the side or rear of any building and having fire resistant walls of two (2) hours or more.
 - 3. If the property is adjacent to a residential zone, an additional five foot (5') setback is required for all structures and parking areas.
 - 4. Landscaping yards are not required within storage or material yards unless adjacent to a residential zone.
2. Clear View: All structures must be placed in conformance with the clear view standards found in SCC 10.16.090. (Ord. 11-03-2014, 11-5-2014, eff. 11-6-2014)

Title 10 Chapter 20 Section 150 is amended as follows: (underlined text is added)

10.20.150 RC RESIDENTIAL COMMERCIAL ZONE

G. Location Requirements; Commercial:

- 1. ~~Front Setback: All buildings and structures shall be set back at least ten feet (10') from the front lot line. (Ord. 2-01-2002, 2-5-2002, eff. 2-5-2002; amd. Ord. 5-03-2015, 6-3-2015, eff. 6-4-2015)~~
- 2. Side Setbacks:
 - a. ~~Interior Lots: Commercial buildings may be designed and constructed to be conjoined or share a common wall along a side property line, with a neighboring commercial building if:~~

- ~~(1) The adjoining building is planned as a part of the same commercial development or plan, whether or not in subsequent phases;~~
- ~~(2) A plan showing the overall commercial development, including all phases, is submitted to the community development department as a part of the applicant's commercial development application;~~
- ~~(3) An architectural design theme is maintained across all conjoined buildings;~~
- ~~(4) All specifications and regulations of the international building code (IBC) and the international fire code (IFC), or subsequently adopted codes, are accounted for and satisfied;~~
- ~~(5) Adequate parking facilities, as outlined in this title, are satisfied in full; and~~
- ~~(6) All other applicable provisions of this code are satisfied.~~

~~Existing commercial buildings located within a commercial zone which have been built with a setback may be remodeled or expanded to incorporate a conjoined situation only if the provisions herein are met in full, however, no building seeking a conjoined approval may overlap a property line to form a conjoined building with an established building containing a setback. Where no conjoined buildings are desired, a ten foot (10') side setback shall be required. The minimum side setback for accessory buildings shall be ten feet (10'), except that a three foot (3') side setback shall be permitted for accessory buildings located at least twelve feet (12') from the rear of any building and having fire resistant walls of two (2) hours or more.~~

- ~~b. Corner Lots: All main and accessory buildings shall be set back from the street side property line a distance of not less than fifteen feet (15'). In addition, no building or structure may be permitted to be located within the clear view area. Interior side property line setbacks shall be determined as specified in paragraph G,2,1. Accessory buildings shall be set back not less than ten feet (10') from the interior side lot line, except that a three foot (3') interior side setback shall also be permitted for accessory buildings located a distance of twelve feet (12') from the rear of the primary structure and having fire resistant walls of two (2) hours or more.~~
- ~~c. Commercial Strips: Two (2) or more commercial buildings may be continually conjoined, as determined herein, provided that no such strip is continued for more than three hundred feet (300') of continual linear building frontage without an easement and/or accessway of at least fifteen feet (15') in width being established to provide emergency access to the rear of the property(ies). Any gap in building frontage of less than ten feet (10') shall be considered continued building frontage. All such commercial strips shall meet the provisions of conjoined buildings as provided in paragraph G,2,1. (Ord. 10-03-2002, 10-16-2002, eff. 10-17-2002; amd. Ord. 5-03-2015, 6-3-2015, eff. 6-4-2015)~~

3. Rear Setbacks:

- ~~a. Interior Lots: All dwellings and other main buildings shall be set back from the rear property line a distance of at least ten feet (10'). Accessory buildings on interior lots shall be set back not less than ten feet (10') from the rear property line, except that a two foot (2') rear setback shall be permitted for accessory~~

buildings having fire resistant walls of two (2) hours or more and located at least twelve feet (12') to the rear of any dwelling.

b. ~~Corner Lots: All dwellings and other main buildings shall be set back from the rear property line a distance of at least ten feet (10'). Accessory buildings on corner lots shall be set back not less than ten feet (10') from the rear property line, except that a two foot (2') rear setback shall be permitted for accessory buildings located at least twelve feet (12') to the rear of any dwelling and having fire resistant walls of two (2) hours or more. (Ord. 7-04-2002, 7-17-2002, eff. 7-23-2002; amd. Ord. 5-03-2015, 6-3-2015, eff. 6-4-2015)~~

4. ~~Clear View: All structures must be placed in conformance with the clear view standards found in SCC 10.16.090. (Ord. 11-03-2014, 11-5-2014, eff. 11-6-2014; amd. Ord. 5-03-2015, 6-3-2015, eff. 6-4-2015)~~
5. ~~Fuel Pumps: Fuel pumps shall be located no closer than thirty feet (30') from any street.~~
6. ~~Residential Setback: The minimum setback from any residential zone or use shall be fifteen feet (15').~~
7. ~~Building Heights:~~
 - a. ~~The minimum allowable height shall be eight feet (8'), measured from the interior ceiling to the exterior grade.~~
 - b. ~~The maximum allowable height shall be forty eight feet (48'), measured from the interior ceiling to the exterior grade. (Ord. 2-01-2002, 2-5-2002, eff. 2-5-2002; amd. Ord. 5-03-2015, 6-3-2015, eff. 6-4-2015)~~

1. Setback Table

RC (Commercial) Setback Requirements				
	Front	Street Side	Side ³	Rear ³
Building	10'	15'	10' or may share common wall if requirements in 10.20.150.G.2 are met.	10'
Accessory Structure	10'	15'	10' ¹	10' ²
Parking	15'	10'	10'	10'
Accessory Structures shall be located at least twelve feet (12') from the dwelling or main structure and shall not be in any utility easements without written consent from those affected entities.				

Notes

1. A three-foot (3') setback along the secondary frontage shall be permitted for an accessory building less than two hundred (200) square feet.
2. A three-foot (3') side or rear setback shall be permitted for accessory buildings if the accessory structure walls closest to the side or rear property line are constructed with one hour or more fire-resistant walls.
3. The minimum setback for all structures and parking areas from any residential zone or use shall be an additional five feet (5').

2. Side Setbacks Exceptions

- a. Interior Lots: Commercial buildings may be designed and constructed to be conjoined or share a common wall along a side property line, with a neighboring commercial building if:
 - (1) The adjoining building is planned as a part of the same commercial development or plan, whether or not in subsequent phases;

- (2) A plan showing the overall commercial development, including all phases, is submitted to the community development department as a part of the applicant's commercial development application;
 - (3) An architectural design theme is maintained across all conjoined buildings;
 - (4) All specifications and regulations of the international building code (IBC) and the international fire code (IFC), or subsequently adopted codes, are accounted for and satisfied;
 - (5) Adequate parking facilities, as outlined in this title, are satisfied in full; and
 - (6) All other applicable provisions of this code are satisfied. Existing commercial buildings located within a commercial zone which have been built with a setback may be remodeled or expanded to incorporate a conjoined situation only if the provisions herein are met in full, however, no building seeking a conjoined approval may overlap a property line to form a conjoined building with an established building containing a setback.
 - (7) Two (2) or more commercial buildings may be continually conjoined, as determined herein, provided that no such strip is continued for more than three hundred feet (300') of continual linear building frontage without an easement and/or accessway of at least fifteen feet (15') in width being established to provide emergency access to the rear of the property(ies). Any gap in building frontage of less than ten feet (10') shall be considered continued building frontage. All such commercial strips shall meet the provisions of conjoined buildings as provided in paragraph G,2,a. (Ord. 10-03-2002, 10-16-2002, eff. 10-17-2002; amd. Ord. 5-03-2015, 6-3-2015, eff. 6-4-2015)
3. Clear View: All structures must be placed in conformance with the clear view standards found in SCC 10.16.090. (Ord. 11-03-2014, 11-5-2014, eff. 11-6-2014; amd. Ord. 5-03-2015, 6-3-2015, eff. 6-4-2015)
 4. Fuel Pumps: Fuel pumps shall be located no closer than thirty feet (30') from any street.
 5. Building Heights:
 - a. The minimum allowable height shall be eight feet (8'), measured from the interior ceiling to the exterior grade.
 - b. The maximum allowable height shall be forty-eight feet (48'), measured from the interior ceiling to the exterior grade. (Ord. 2-01-2002, 2-5-2002, eff. 2-5-2002; amd. Ord. 5-03-2015, 6-3-2015, eff. 6-4-2015)

H. Location Requirements; Residential:

1. ~~Dwellings And Other Main Buildings:~~
 - a. ~~Front Setback: Thirty feet (30') from the front lot line.~~
 - b. ~~Front Setback On Corner Lot: Thirty feet (30') from property line along primary frontage, twenty five feet (25') from property line along secondary frontage.~~
 - c. ~~Side Setback: Ten feet (10') from side property line.~~
 - d. ~~Rear Setback: Twenty five feet (25') from rear property line.~~
 - e. ~~Setback Modification: A property which fronts onto an urban or multiuse, nonequestrian trail corridor, as shown in the adopted parks, recreation and open space master plan, may reduce the front setback along such corridor. The setback reduction may not exceed the width of such corridor, as measured from back of curb, and a minimum ten foot (10') setback must be maintained. The~~

modification must still provide for twenty four feet (24') of parking between the structure and the lot line. (Ord. 5-05-2015, 5-6-2015, eff. 5-7-2015)

2. ~~Accessory Structures (Including Detached Garages):~~
 - a. ~~General Setbacks: All accessory structures must be located at least twelve feet (12') from any associated dwelling or main structure and may not be located in any utility easements without written consent from those affected entities.~~
 - b. ~~Front Setback: Accessory structures are not permitted in the front yard of a dwelling.~~
 - c. ~~Front Setback On Corner Lot: Accessory structures are not permitted in the front yard of a dwelling along a primary frontage nor within twenty five feet (25') from secondary frontages except that accessory structures that are less than two hundred (200) square feet may be within the setback from a secondary frontage if the accessory structure is located at least three feet (3') from the property line that is along a secondary frontage.~~
 - d. ~~Side Setback: Accessory structures must be ten feet (10') from a side property line, except that a three foot (3') side setback shall be permitted if the accessory structure walls closest to the side property line are constructed with one hour or more fire resistant walls.~~
 - e. ~~Rear Setback: Accessory structures must be ten feet (10') from the rear property line, except that a three foot (3') rear setback shall be permitted if the accessory structure walls closest to the rear property line are constructed with one hour or more fire resistant walls. (Ord. 02-03-2018, 4-4-2018, eff. 4-5-2018)~~

1. Setbacks

<u>RC (Residential) Setback Requirements</u>				
	<u>Front</u>	<u>Street Side</u>	<u>Side</u>	<u>Rear</u>
<u>Building</u>	<u>30'¹</u>	<u>25'</u>	<u>10'</u>	<u>25'</u>
<u>Parking Lot (Multifamily)</u>	<u>15'</u>	<u>10'</u>	<u>10'</u>	<u>10'</u>
<u>Accessory Structure</u>	<u>Not permitted</u>	<u>25'²</u>	<u>10'³</u>	<u>10'³</u>
<u>Accessory Structures shall be located at least twelve feet (12') from the dwelling or main structure and shall not be in any utility easements without written consent from those affected entities.</u>				

Notes:

1. A property that fronts onto an urban or multiuse, non-equestrian trail corridor, as shown in the adopted Parks, Recreation, and Open Space Master Plan, may reduce the front setback along such corridor. The setback reduction may not exceed the width of such corridor, as measured from the back of curb, and a minimum ten-foot (10') setback must be maintained. The modification must still provide twenty-four feet (24') of parking between the structure and the lot line.
2. A three-foot (3') setback along the secondary frontage shall be permitted for an accessory building less than two hundred (200) square feet.
3. A three-foot (3') side or rear setback shall be permitted for accessory buildings if the accessory structure walls closest to the side or rear property line are constructed with one hour or more fire-resistant walls.

2. Clear View: All structures must be placed in conformance with the clear view standards found in SCC 10.16.090. (Ord. 03-02-2006, 3-1-2006, eff. 3-2-2006; amd. Ord. 5-03-2015, 6-3-2015, eff. 6-4-2015)
- I. Size Of Building And Lot: Minimum lot area is 8,000 square feet (9,025 square feet for corner lots). All residential structures within this zone shall be a minimum of nine hundred (900) square feet floor area on the main floor. (Ord. 2-01-2002, 2-5-2002, eff. 2-5-2002; amd. Ord. 5-03-2015, 6-3-2015, eff. 6-4-2015)
 - J. Special Provisions:
 1. All materials and merchandise, except vehicles in running order, shall be stored in an enclosed building or within an enclosure surrounded by a sight obscuring fence or wall of not less than six feet (6') and no materials or merchandise shall be stored to a height of more than the enclosing fence or wall.
 2. Storage of junk, partially or completely dismantled automobiles, or salvage materials shall be prohibited.
 3. No solid waste container shall be located in the front yard setback area, nor thirty feet (30') from any public street. All dumpsters shall be screened from the public view by a six foot (6') sight obscuring wall or fence. The floor of the trash enclosure shall be a concrete pad which shall extend five feet (5') beyond the opening of the trash enclosure. Trash enclosures shall be located so as to minimize disturbance to residential development. Trash enclosures shall be at least fifty feet (50') away from any residential use. (Ord. 2-01-2002, 2-5-2002, eff. 2-5-2002; amd. Ord. 5-03-2015, 6-3-2015, eff. 6-4-2015)
 4. Development landscaping shall be in accordance with SCC 10.52, "Landscaping Standards". (Ord. 12-02-2006, 12-6-2006, eff. 12-7-2006; amd. Ord. 5-03-2015, 6-3-2015, eff. 6-4-2015)

K. Property Development Standards:

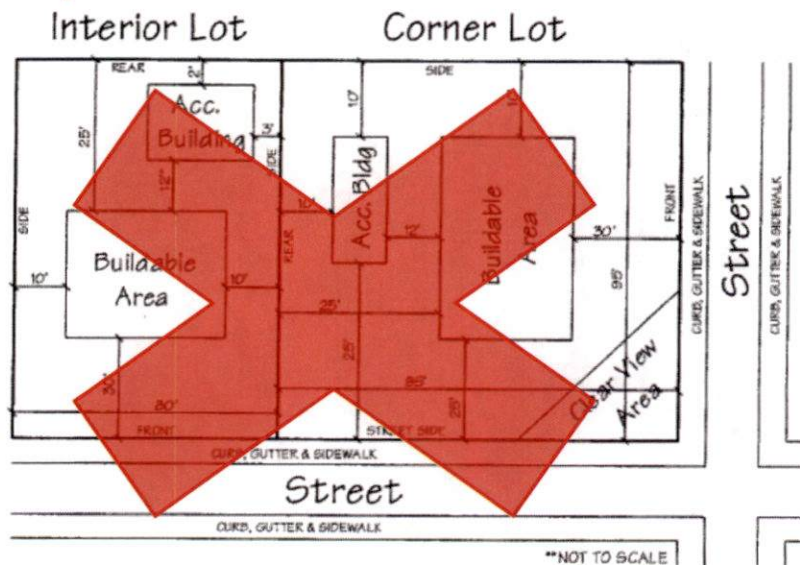

- All setbacks and lot dimensions are minimums unless otherwise noted.
- Property lines shown are in accordance with the Santaquin City construction standards and details and are usually not located at the back of the sidewalk.
- Minimum lot area: 8,000 square feet (9,025 square feet for corner lots).
- Accessory building setbacks may be reduced, as shown on the typical lot above, as outlined in this code.
- Minimum dwelling size: 900 square feet.
- Clear view area: The size, location and regulation of the clear view area of corner lots

are determined according to SCC 10.16.090 and do not necessarily reflect the representation in the diagram above.

*Accessory building setback measured to the closest point of the primary structure.

Zoning Requirements: RC Property Development Standards
Commercial Site: Interior And Corner Lots

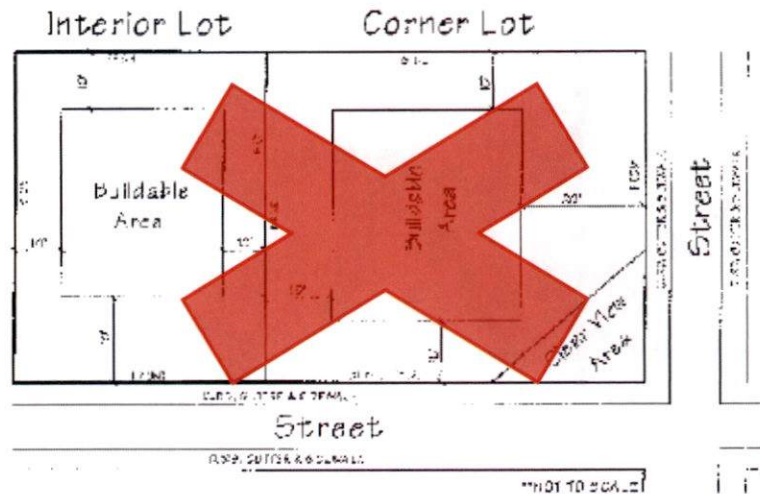

-All setbacks and lot dimensions are minimums unless otherwise noted.

-Property lines shown are in accordance with the Santaquin City construction standards and details and are usually not located at the back of the sidewalk.

-Clear view area: The size, location and regulation of the clear view area of corner lots are determined according to SCC 10.16.090 and do not necessarily reflect the representation in the diagram above.

Title 10 Chapter 20 Section 180 is amended as follows: (underlined text is added)

10.20.180 PUBLIC FACILITIES ZONE

E. Location Requirements

1. **Front Setback:** All buildings and structures shall be set back at least twenty feet (20') from the front lot line.
2. **Side Setbacks:**
 - a. Interior lots: All buildings shall be set back from the side property line a distance of at least ten feet (10').
 - b. Corner lots: All buildings shall be set back from any street not less than twenty-five feet (25').
3. **Rear Setback:**
 - a. Interior lots: All buildings shall be set back from the rear property line a distance of at least ten feet (10').
 - b. Corner lots: All dwellings and other main buildings shall be set back from the rear property line a distance of at least ten feet (10'). (Ord. 12-01-2002, 12-4-2002, eff. 12-5-2002)
4. **Clear View:** All structures must be placed in conformance with the clear view standards found in SCC 10.16.090. (Ord. 11-03-2014, 11-5-2014, eff. 11-6-2014)

1. Setbacks

PF Setback Requirements

	<u>Front</u>	<u>Street Side</u>	<u>Side</u>	<u>Rear</u>
<u>Buildings</u>	<u>20'</u>	<u>25'</u>	<u>10'</u>	<u>10'</u>

2. Clear View: All structures must be placed in conformance with the clear view standards found in SCC 10.16.090. (Ord. 11-03-2014, 11-5-2014, eff. 11-6-2014)

Title 10 Chapter 20 Section 190 is amended as follows: (underlined text is added)

10.20.190 MAIN STREET BUSINESS DISTRICTS ZONE

E. Site Layout Standards: The location and orientation of buildings, pedestrian walkways and parking areas helps define the street edge, promote a pedestrian oriented street environment for walking and shopping, and limits impacts of taller buildings on the adjacent residences north or south of the district. (Ord. 08-02-2008, 8-20-2008, eff. 8-21-2008)

1. Building Locations and Setbacks
 - a. Buildings on corner parcels should be adjacent to both street fronts to help frame intersections. Architectural consideration should be given to corner visibility areas.
 - b. Buildings fronting Main Street should utilize party walls or zero setbacks alongside property lines. Parking areas and drive access should not disrupt the continuity of storefronts; however, plazas, green spaces or pedestrian connections may be appropriate.
 - c. Setbacks:

	<u>MBD</u>		
	<u>CBD</u>	<u>MSC</u>	<u>MSR</u>
<u>Front and Street Side:</u>			
<u>Minimum Building</u> ¹	10'	10'	10'
<u>Maximum Building</u> ¹	Main Street - 10'	10'	15'
	Center Street - 10'	N/A	N/A
	Other Streets - 10'	10'	15'
<u>Parking</u>	<u>10'</u>	<u>10'</u>	<u>10'</u>
<u>Side:</u>			
<u>Minimum Building</u> ²	0' or 8' if not built to the property line if mixed use or nonresidential structure with building code rated firewall		10' to nonresidential or mixed-use structures
	8' if nonrated firewall with windows		
	5' accessory buildings and structures		
	10' loading dock, with approved screening		
<u>Maximum Building</u> ²	0' or 8' if not built to the property line	N/A	N/A
<u>Parking</u> ²	<u>5'</u>	<u>5'</u>	<u>5'</u>

<u>Rear:</u>			
<u>Minimum Building</u> ²	0' if building code rated firewall		20'
	20' if nonrated firewall with windows		
	5' accessory buildings and structures		
	10' loading dock, with approved screening		
<u>Parking</u> ²	<u>5'</u>	<u>5'</u>	<u>5'</u>

Note:

- In the CBD area 90 percent of the primary building must fall on the build-to line (front setback). Architectural elements such as pilasters, columns, cornices, box or bay windows, or other typical ornamentations may protrude into the required setback a maximum of 2 feet. However, primary building wall planes are not allowed to extend or be cantilevered into the required setbacks.
- If property is adjacent to a residential zone, an additional five-foot (5') setback is required for all structures.

L. Detached Single-Family Development Standards:

~~2.—Structure Setbacks:~~

- ~~Front setbacks to living area from all street fronting property lines: Fifteen feet (15'). Covered porches may be within ten feet (10') of the front property line. Required clear view areas may not be obstructed.~~
- ~~Front setback to garage doors: Twenty five feet (25').~~
- ~~Side setback: Five feet (5').~~
- ~~Rear setback: Twenty five feet (25').~~
- ~~Accessory structures shall not be located in front of the main structure and must comply with setback requirements for accessory structures in other single family zones of the city.~~

2. Setbacks

<u>Single Family Setback Requirements</u>				
	<u>Front</u>	<u>Street Side</u>	<u>Side</u>	<u>Rear</u>
<u>Building</u>	<u>25' to garage doors</u> <u>15' to living area</u> <u>10' to covered porch</u>	<u>25' to garage doors</u> <u>15' living area</u>	<u>5'</u>	<u>25'</u>
<u>Nonresidential Use Parking</u>	<u>20'</u>	<u>20'</u>	<u>5'</u>	<u>5'</u>
<u>Accessory Structure</u>	<u>Not permitted</u>	<u>25'¹</u>	<u>10'²</u>	<u>10'²</u>
<u>Accessory Structures shall be located at least twelve feet (12') from the dwelling or main structure and shall not be in any utility easements without written consent from those affected entities.</u>				

Notes

- A three-foot (3') setback along the secondary frontage shall be permitted for an accessory building less than two hundred (200) square feet.
- A three-foot (3') side or rear setback shall be permitted for accessory buildings if the accessory structure walls closest to the side or rear property line are constructed with one hour or more fire-resistant walls.

Title 10 Chapter 20 Section 220 is amended as follows: (underlined text is added)

10.20.220 R-43 RESIDENTIAL ZONE

E. Structure Requirements:

~~1.—Setbacks~~

Yard	R-43
Front yard	50 feet from public road or centerline of private road
	40 feet from shared driveway
Secondary front yard	30 feet
Side yard	20 feet
Rear yard	30 feet

(Ord. 06-01-2011, 6-1-2011, eff. 6-2-2011)

2. ~~Accessory Structures (Including Detached Garages):~~

- a. ~~General Setbacks: All accessory structures must be located at least twelve feet (12') from any associated dwelling or main structure and may not be located in any utility easements without written consent from those affected entities.~~
- b. ~~Front Setback: Accessory structures are not permitted in the front yard of a dwelling.~~
- c. ~~Front Setback On Corner Lot: Accessory structures are not permitted in the front yard of a dwelling along a primary frontage nor within thirty feet (30') from secondary frontages except that accessory structures that are less than two hundred (200) square feet may be within the setback from a secondary frontage if the accessory structure is located at least three feet (3') from the property line that is along a secondary frontage.~~
- d. ~~Side Setback: Accessory structures must be ten feet (10') from a side property line, except that a three foot (3') side setback shall be permitted if the accessory structure walls closest to the side property line are constructed with one hour or more fire resistant walls.~~
- e. ~~Rear Setback: Accessory structures must be ten feet (10') from the rear property line, except that a three foot (3') rear setback shall be permitted if the accessory structure walls closest to the rear property line are constructed with one hour or more fire resistant walls. (Ord. 02-03-2018, 4-4-2018, eff. 4-5-2018)~~

3. ~~Clear View: All structures must be placed in conformance with the clear view standards found in SCC 10.16.090. (Ord. 06-01-2011, 6-1-2011, eff. 6-2-2011)~~

1. Setbacks

<u>R-43 Setback Requirements</u>				
	<u>Front</u>	<u>Street Side</u>	<u>Side</u>	<u>Rear</u>
<u>Building</u>	<u>50' public road or centerline of private road, 40' shared driveway</u>	<u>30'</u>	<u>20'</u>	<u>30'</u>
<u>Nonresidential Use Parking</u>	<u>20'</u>	<u>20'</u>	<u>5'</u>	<u>5'</u>
<u>Accessory Structure</u>	<u>Not Permitted</u>	<u>30'¹</u>	<u>10'²</u>	<u>10'²</u>
<u>Accessory Structures shall be located at least twelve feet (12') from the dwelling or main structure and shall not be in any utility easements without written consent from those affected entities.</u>				

Notes

1. A three-foot (3') setback along the secondary frontage shall be permitted for an accessory building less than two hundred (200) square feet.
 2. A three-foot (3') side or rear setback shall be permitted for accessory buildings if the accessory structure walls closest to the side or rear property line are constructed with one hour or more fire-resistant walls.
 2. Clear View: All structures must be placed in conformance with the clear view standards found in SCC 10.16.090. (Ord. 03-02-2006, 3-1-2006, eff. 3-2-2006; amd. Ord. 07-01-2011, 7-27-2011, eff. 7-28-2011)
- F. Dwelling Size: Minimum dwelling size shall be one thousand two hundred (1,200) square feet floor area on the main floor. (Ord. 06-01-2011, 6-1-2011, eff. 6-2-2011)
- G. Property Development Standards:
1. Water Systems: Sufficient culinary and irrigation water rights and/or systems must be provided to each new lot created within this zone. Private water systems are not allowed if the buildings serviced in the development are within one thousand feet (1,000') of an existing public water system. (Ord. 09-04-2011, 9-21-2011, eff. 9-22-2011)
 2. Sewer Systems: Individual or communal septic tanks may be utilized for new homes based on compliance with all applicable City, State and Federal provisions, including, but not limited to, water source protection areas. Homes within three hundred feet (300') of a public sewer system must connect to the public system. Provision must be made with any new development for the eventual connection of dwellings to a public system. This may include installing dry sewer lines and stubs lines.
 3. Sensitive Lands: Environmentally sensitive lands (e.g., natural stream channels, floodplains, steep slopes, etc.) may not be included with lots as buildable areas. Such lands may be included with lots but shall not count toward the minimum lot area. The City Council may accept these lands as permanent open space for general City recreation, scenic, or cultural purposes.
 4. Access:
 - a. Roads: All properties must be accessed from improved public or private roads that comply with all public safety accessibility standards. Private roads may only be approved where documentation of a permanent maintenance and funding plan is provided. Though private roads are not encouraged, they are allowed with City Council approval, whether or not a public road could be constructed with property development constraints.
 - b. Driveways: Properties may utilize shared driveways for access up to two (2) lots. Shared driveways may only be approved where documentation of a permanent maintenance and funding plan is provided as well as appropriate deeds establishing unilateral control and responsibility for the driveway between the benefited properties.
 5. Development Agreements: Any property owner(s) wanting to develop within this zone must enter into a development agreement with the City prior to preliminary development approvals being granted. Such agreements should address the above development standards and any other criteria deemed appropriate by the property owner or City. (Ord. 06-01-2011, 6-1-2011, eff. 6-2-2011)

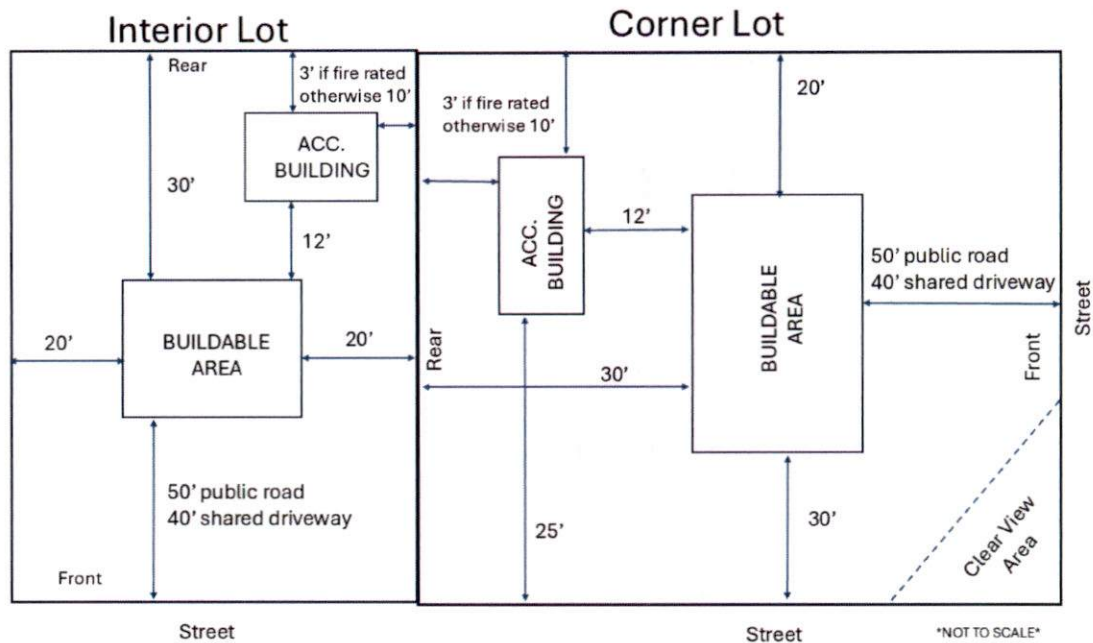

Title 10 Chapter 20 Section 240 is amended as follows: (underlined text is added)

10.20.240 CLM Commercial Light Manufacturing

D. Location Requirements; Commercial:

1. ~~Front Setback: All buildings and structures shall be set back at least ten feet (10') from the front lot line.~~
2. ~~Side Setbacks:~~
 - a. ~~Interior Lots: Commercial buildings may be designed and constructed to be conjoined or share a common wall along a side property line, with a neighboring commercial building if:~~
 - (1) ~~The adjoining building is planned as a part of the same commercial development or plan, whether or not in subsequent phases;~~
 - (2) ~~A plan showing the overall commercial development, including all phases, is submitted to the community development department as a part of the applicant's commercial development application;~~
 - (3) ~~All specifications and regulations of the International Building Code (IBC) and the International Fire code (IFC), or subsequently adopted codes, are accounted for and satisfied;~~
 - (4) ~~Adequate parking facilities, as outlined in this title, are satisfied in full; and~~
 - (5) ~~All other applicable provisions of this code are satisfied. Existing commercial buildings located within a commercial zone which have been built with a setback may be remodeled or expanded to incorporate a conjoined situation only if the provisions herein are met in full. No building seeking a conjoined approval may overlap a property line to form a conjoined building with an established building containing a setback. Where no conjoined buildings are desired, a ten-foot (10') side setback shall be required. The minimum side setback for accessory buildings shall be ten feet (10'), except that a three-foot (3') side setback shall be permitted for accessory buildings located at least twelve feet~~

- (12') from the rear of any building and having fire resistant walls of two (2) hours or more.
- b. **Corner Lots:** All main and accessory buildings shall be set back from the street side property line a distance of not less than fifteen feet (15'). In addition, no building or structure may be permitted to be located within the clear view area. Interior side property line setbacks shall be determined as specified in paragraph G,2,1. Accessory buildings shall be set back not less than ten feet (10') from the interior side lot line, except that a three foot (3') interior side setback shall also be permitted for accessory buildings located a distance of twelve feet (12') from the rear of the primary structure and having fire resistant walls of two (2) hours or more.
3. **Commercial Strips:** Two (2) or more commercial buildings may be continually conjoined, as determined herein, provided that no such strip is continued for more than three hundred feet (300') of continual linear building frontage without an easement and/or accessway of at least fifteen feet (15') in width being established to provide emergency access to the rear of the property(ies). Any gap in building frontage of less than ten feet (10') shall be considered continued building frontage. All such commercial strips shall meet the provisions of conjoined buildings as provided in paragraph G,2,1.
 4. **Rear Setback:**
 - a. **Interior Lots:** All dwellings and other main buildings shall be set back from the rear property line a distance of at least ten feet (10'). Accessory buildings on interior lots shall be set back not less than ten feet (10') from the rear property line, except that a two foot (2') rear setback shall be permitted for accessory buildings having fire resistant walls of two (2) hours or more and located at least twelve feet (12') to the rear of any dwelling.
 - b. **Corner Lots:** All dwellings and other main buildings shall be set back from the rear property line a distance of at least ten feet (10'). Accessory buildings on corner lots shall be set back not less than ten feet (10') from the rear property line, except that a two foot (2') rear setback shall be permitted for accessory buildings located at least twelve feet (12') to the rear of any dwelling and having fire resistant walls of two (2) hours or more.
 5. **Clear View:** All structures must be placed in conformance with the clear view standards found in SCC 10.16.090.
 6. **Fuel Pumps:** Fuel pumps shall be located no closer than thirty feet (30') from any street.
 7. **Residential Setback:** The minimum setback from any residential zone or use shall be fifteen feet (15').

1. Setback Table

<u>CLM (Commercial) Setback Requirements</u>				
	<u>Front</u>	<u>Street Side</u>	<u>Side³</u>	<u>Rear³</u>
<u>Building</u>	<u>10'</u>	<u>15'</u>	<u>10' or may share common wall if requirements in SCC 10.20.240.D.2 are met.</u>	<u>10'</u>
<u>Accessory Structure</u>	<u>10'</u>	<u>15'</u>	<u>10'¹</u>	<u>10'²</u>
<u>Parking</u>	<u>15'</u>	<u>10'</u>	<u>10'</u>	<u>10'</u>
<u>Accessory Structures shall be located at least twelve feet (12') from the dwelling or main structure and shall not be in any utility easements without written consent from those affected entities.</u>				

Notes

1. A three-foot (3') side setback shall be permitted for accessory buildings located at least twelve feet (12') from the side or rear of any building and having fire resistant walls of two (2) hours or more.
 2. A two-foot (2') rear setback shall be permitted for accessory buildings located at least twelve feet (12') from the side or rear of any building and having fire resistant walls of two (2) hours or more.
 3. The minimum setback for all structures and parking areas from any residential zone or use shall be an additional five feet (5').
2. Side Setback Exceptions:
- a. Interior Lots: Commercial buildings may be designed and constructed to be conjoined or share a common wall along a side property line, with a neighboring commercial building if:
 - (1) The adjoining building is planned as a part of the same commercial development or plan, whether or not in subsequent phases;
 - (2) A plan showing the overall commercial development, including all phases, is submitted to the community development department as a part of the applicant's commercial development application;
 - (3) All specifications and regulations of the International Building Code (IBC) and the International Fire code (IFC), or subsequently adopted codes, are accounted for and satisfied;
 - (4) Adequate parking facilities, as outlined in this title, are satisfied in full; and
 - (5) All other applicable provisions of this code are satisfied. Existing commercial buildings located within a commercial zone which have been built with a setback may be remodeled or expanded to incorporate a conjoined situation only if the provisions herein are met in full. No building seeking a conjoined approval may overlap a property line to form a conjoined building with an established building containing a setback.
 - (6) Commercial Strips: Two (2) or more commercial buildings may be continually conjoined, as determined herein, provided that no such strip is continued for more than three hundred feet (300') of continual linear building frontage without an easement and/or accessway of at least fifteen feet (15') in width being established to provide emergency access to the rear of the property(ies). Any gap in building frontage of less than ten feet (10') shall be considered continued building frontage. All such commercial strips shall meet the provisions of conjoined buildings as provided in paragraph G,2,a.
3. Clear View: All structures must be placed in conformance with the clear view standards found in SCC 10.16.090.
 4. Fuel Pumps: Fuel pumps shall be located no closer than thirty feet (30') from any street.
 5. Building Heights:
 - a. The minimum allowable height shall be eight feet (8'), measured from the interior ceiling to the exterior grade.
 - b. The maximum allowable height shall be forty-eight feet (48'), measured from the interior ceiling to the exterior grade.

E. Location Requirements; Light Manufacturing:

1. All Buildings and Structures:
 - a. Front Setback: Thirty five feet (35') from the front lot line.
 - b. Front Setback On Corner Lot: Thirty five feet (35') from property line along primary frontage, thirty feet (30') from property line along secondary frontage.
 - c. Side Setbacks:

~~(1) Interior Lots: All main buildings shall be set back from the side property line a distance of at least ten feet (10'), and the sum of the total distance of the two (2) side setbacks shall be at least twenty feet (20'). Accessory buildings on interior lots shall be set back from the side property line a distance of at least ten feet (10'), except that a three-foot (3') side setback shall be permitted for accessory buildings located at least twelve feet (12') to the rear of any main building and having fire resistant walls of two (2) hours or more.~~

~~(2) Corner Lots: All main and accessory buildings shall be set back from any street not less than twenty-five feet (25'). Accessory buildings shall be set back not less than ten feet (10') from the interior side lot line, except that a three-foot (3') interior side setback shall also be permitted for accessory buildings located a distance of twelve feet (12') from the rear of the primary structure and having fire resistant walls of two (2) hours or more.~~

d. **Rear Setback:**

~~(1) Interior Lots: All dwellings and other main buildings shall be set back from the rear property line a distance of at least ten feet (10'). Accessory buildings on interior lots shall be set back not less than ten feet (10') from the rear property line, except that a two-foot (2') rear setback shall be permitted for accessory buildings having fire resistant walls of two (2) hours or more and located at least twelve feet (12') to the rear of any dwelling.~~

~~(2) Corner Lots: All dwellings and other main buildings shall be set back from the rear property line a distance of at least ten feet (10'). Accessory buildings on corner lots shall be set back not less than ten feet (10') from the rear property line, except that a two-foot (2') rear setback shall be permitted for accessory buildings located at least twelve feet (12') to the rear of any dwelling and having fire resistant walls of two (2) hours or more.~~

1. **Setbacks**

<u>CLM (Light Industrial) Setback Requirements</u>				
	<u>Front</u>	<u>Street Side</u>	<u>Side³</u>	<u>Rear³</u>
<u>Building</u>	<u>35'</u>	<u>25'</u>	<u>10'</u>	<u>10'</u>
<u>Accessory Structure</u>	<u>35'</u>	<u>25'</u>	<u>10'¹</u>	<u>10'²</u>
<u>Parking</u>	<u>20'</u>	<u>20'</u>	<u>10'⁴</u>	<u>10'⁴</u>
<u>Accessory Structures shall be located at least twelve feet (12') from the dwelling or main structure and shall not be in any utility easements without written consent from those affected entities.</u>				

Notes

1. A three-foot (3') side setback shall be permitted for accessory buildings located at least twelve feet (12') from the side or rear of any building and having fire resistant walls of two (2) hours or more.
2. A two-foot (2') rear setback shall be permitted for accessory buildings located at least twelve feet (12') from the side or rear of any building and having fire resistant walls of two (2) hours or more.
3. If property is adjacent to a residential zone, an additional five-foot (5') setback is required for all structures and parking areas.
4. Landscaping yards are not required within storage or material yards unless adjacent to a residential zone.

2. Clear View: All structures must be placed in conformance with the clear view standards found in SCC 10.16.090.
3. Size of building: The ground floor area of all building has not been specified
4. Building Heights:
 - a. The minimum allowable height shall be eight feet (8'), measured from the interior ceiling to the exterior grade.
 - b. The maximum allowable height shall be forty -eight feet (48'), measured from the interior ceiling to the exterior grade.

Title 10 Chapter 52 Section 30 is amended as follows: (underlined text is added)

10.52.030 DEVELOPMENT PROJECT LANDSCAPING REQUIREMENTS

B. General Landscaping Standards: The following requirements and recommendations apply to all landscaping projects that are subject to city review.

8. Landscaping percentages

<u>Minimum Landscaping Requirements</u>	
<u>MBD (Commercial/Mixed Use)</u>	<u>20%</u>
<u>MBD (Multifamily)</u>	<u>30%</u>
<u>C-1</u>	<u>10%</u>
<u>RC (Commercial)</u>	<u>10%</u>
<u>RC (Multifamily)</u>	<u>30%</u>
<u>PC</u>	<u>10%</u>
<u>I-1 & CLM</u>	<u>8%</u>
<u>PO</u>	<u>10%</u>
<u>NONRESIDENTIAL IN RESIDENTIAL</u>	<u>15%</u>

C. Landscape Yards And Screening:

1. Required Landscape Yards: ~~The following landscaping yards and buffers are required as listed in table 1 of this section:~~ See individual zones for parking and building setbacks. Area that is not being used for building or parking must be landscaped.

**TABLE 1
REQUIRED LANDSCAPE YARDS AND AREAS**

Zone/Use	Front To Building/To Parking	Street Side To Building/To Parking	Side	Rear	Side Or Rear Abutting A Residential Zone¹	Minimum Percentage Of Landscape Area
MBD along Main Street (200 W to 100 E)	10'/10' ²	10'/10' ²	5' ³	5'	5'	See MBD development standards
C-1	Landscape yards within these zones shall be established in relationship to required setbacks for buildings and parking areas					10%
RC	30'/15'	20'/10'	10'	10'	20'	10%
PC	30'/15' ²	20'/10' ²	10'	10'	20'	10%

I-I	35'/20'	25'/20'	10' ⁴	10' ⁴	15'	8%
PO	30'/15'	20'/10'	10'	20'	20'	10%
Multiple-unit residential dwellings ⁵	30'/20'	30'/20'	20'	30'	30'	See multi-family development standards
Core area (multi-family/nonresidential) other than MBD	20'/20'	15'/20'	10'	20'	20'	10%
Nonresidential uses that may be appropriate in a residential zone	30'/20'	30'/20'	5'	5'	10'	15%

Notes:

- 1.—A site is considered to abut a residential zone even if the residential zone begins at the centerline of an adjacent public street to the rear or side of the proposed development.
- 2.—Where sites are constructed with outdoor eating and display areas along the public right of way, a maximum of 60 percent of this area may include pavers or other city-approved hardscape.
- 3.—This side yard requirement for the building can be waived when the associated building is constructed with 0 setback from a side property line and an adjoining building is or will be constructed with a similar 0 setback as part of a master planned development or plans for the adjoining site are under review by the city.
- 4.—Landscaping yards are not required within storage or material yards unless adjacent to a residential zone.
- 5.—Landscape yards are to be established from the outer walls of any attached unit structures.

Section II. Severability

If any part of this ordinance or the application thereof to any person or circumstances shall, for any reason, be adjudged by a court of competent jurisdiction to be unconstitutional or invalid, such judgment shall not affect, impair or invalidate the remainder of this ordinance or the application thereof to other persons and circumstances, but shall be confined to its operation to the section, subdivision, sentence or part of the section and the persons and circumstances directly involved in the controversy in which such judgment shall have been rendered. It is hereby declared to be the intent of the City Council that this section would have been adopted if such invalid section, provisions, subdivision, sentence or part of a section or application had not been included.

Section III. Contrary Provisions Repealed

Any and all other provisions of the Santaquin City Code that are contrary to the provisions of this Ordinance are hereby repealed.

Section IV. Codification, Inclusion in the Code, and Scrivener's Errors

It is the intent of the City Council that the provisions of this ordinance be made part of the Santaquin City Code as adopted, that sections of this ordinance may be re-numbered or re-lettered, and that the word ordinance may be changed to section, chapter, or other such appropriate word or phrase in order to accomplish such intent regardless of whether such inclusion in a code is accomplished. Typographical errors which do not affect the intent of this ordinance may be authorized by the City without need of public hearing by its filing a corrected or re-codified copy of the same with the City Recorder.

Section V. Posting and Effective Date

This ordinance shall become effective at 5:00 p.m. on Wednesday, February 5, 2025. Prior to that time, the City Recorder shall deposit a copy of this ordinance in the official records of the City and place a copy of this ordinance in three places within the City.

PASSED AND ADOPTED this 4th day of February 2025.



Daniel M. Olson, Mayor



Councilmember Art Adcock	Voted <u>YES</u>
Councilmember Brian Del Rosario	Voted <u>YES</u>
Councilmember Lynn Mecham	Voted <u>YES</u>
Councilmember Jeff Siddoway	Voted <u>YES</u>
Councilmember Travis Keel	Voted <u>YES</u>

ATTEST:



Amalie R. Ottley, City Recorder

STATE OF UTAH)
) ss.
COUNTY OF UTAH)

I, AMALIE R. OTTLEY, City Recorder of Santaquin City, Utah, do hereby certify and declare that the above and foregoing is a true, full, and correct copy of an ordinance passed by the City Council of Santaquin City, Utah, on the 4th day of February 2025, entitled

“AN ORDINANCE AMENDING SANTAQUIN CITY CODE TO ADOPT SETBACK TABLES AND UPDATE SETBACK FIGURES PROVIDING FOR CODIFICATION, CORRECTION OF SCRIVENER’S ERRORS, SEVERABILITY, AND AN EFFECTIVE DATE FOR THE ORDINANCE.”

IN WITNESS WHEREOF, I have hereunto set my hand and affixed the Corporate Seal of Santaquin City Utah this 4th day of February 2025.



Amalie R. Ottley
Santaquin City Recorder



(SEAL)

AFFIDAVIT OF POSTING

STATE OF UTAH)
) ss.
COUNTY OF UTAH)

I, AMALIE R. OTTLEY, City Recorder of Santaquin City, Utah, do hereby certify and declare that prior to the ordinance taking effect, I posted a short summary of the ordinance on the Utah Public Notice Website as required by Utah State Code 10-3-711(1)(b) as a Class A Notice and Santaquin City Code 1-2-050(D)

I further certify that copies of the ordinance were posted online at www.santaquin.org, at the City Hall Building at 110 S. Center Street and on the State of Utah's Public Notice Website, <https://www.utah.gov/pmn/index.html>. A copy of the notice may also be requested by calling (801)754-1904.



AMALIE R. OTTLEY
Santaquin City Recorder

The foregoing instrument was acknowledged before me on this 5th day of Feb 2025, by AMALIE R. OTTLEY.

My Commission Expires: 04-19-2026



Notary Public

