

ZONING

SINGLE-FAMILY DETACHED

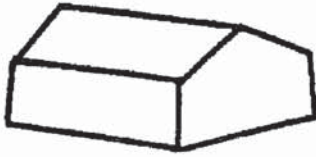

No party wall,
one family

SINGLE-FAMILY SEMI-DETACHED

One party wall,
each dwelling
on its own lot.

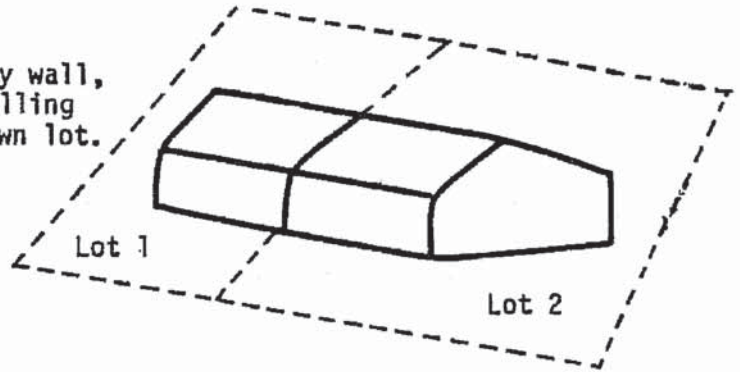

TWO FAMILY

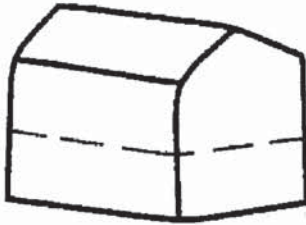

Two families, one unit per floor

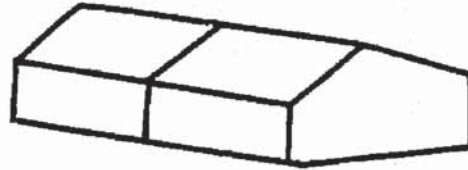

One party wall, two families,
both units on same lot

MULTI-FAMILY



Two or more party walls,
three or more families,
all units on one lot

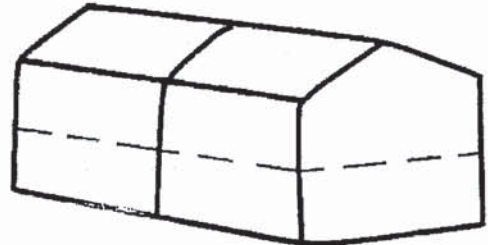

One or more party walls,
four or more families,
all units on one lot

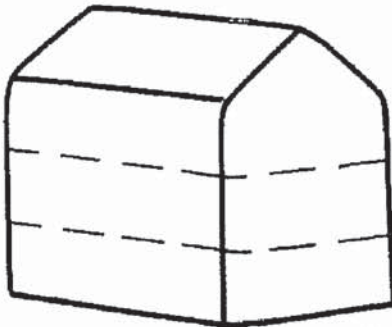

Three or more stories,
three or more families

TYPES OF
DWELLINGS

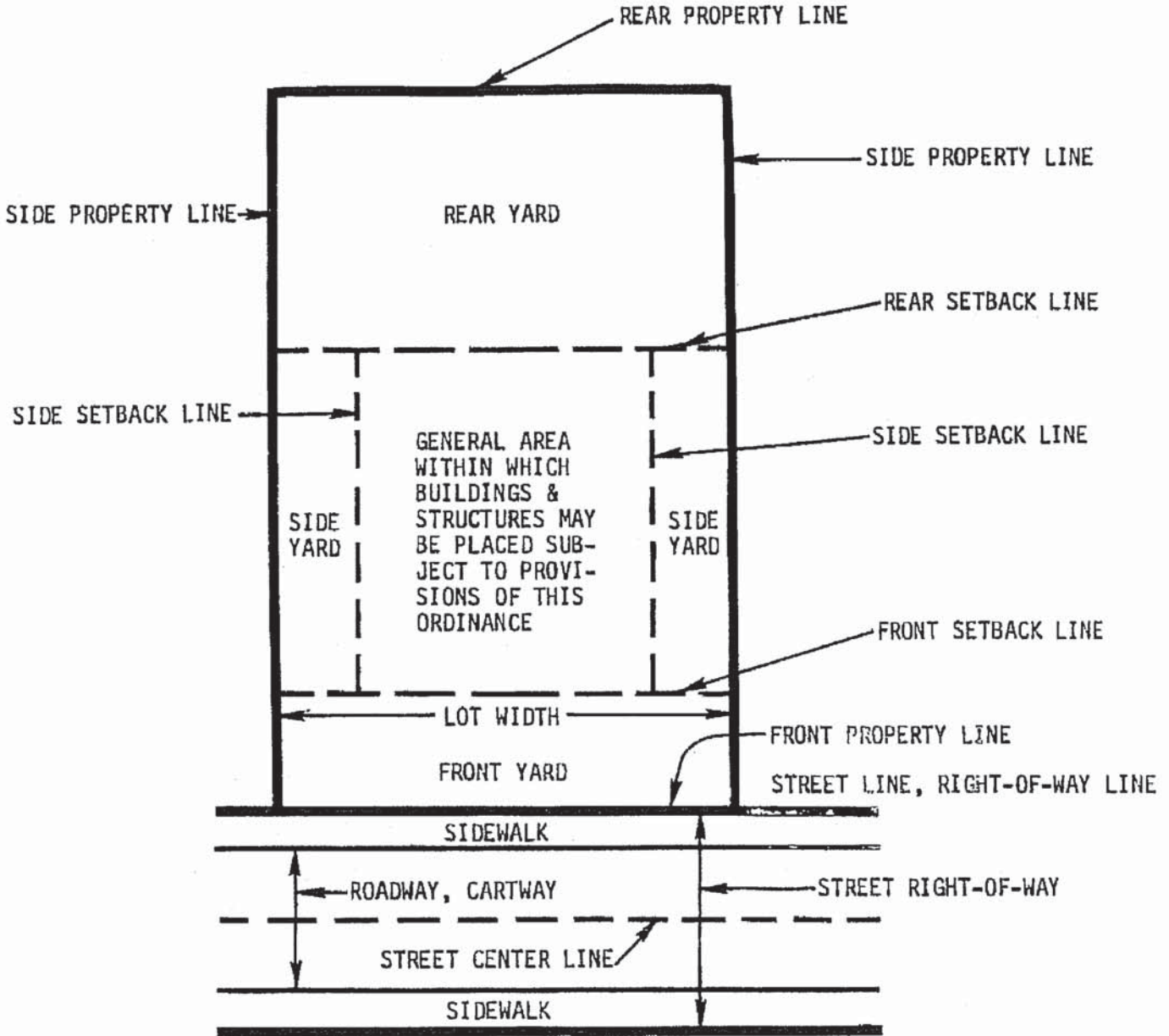

SKETCH PLAN DEPICTING SELECTED ZONING TERMS