

BREA CODE

Diagram B

<i>For 9 Foot Wide Stalls</i>						
		<i>Angle</i>				
<i>Dimension</i>	<i>On Diagram</i>	<i>30°</i>	<i>45°</i>	<i>60°</i>	<i>75°</i>	<i>90°</i>
<i>For 9 Foot Wide Stalls</i>						
		<i>Angle</i>				
<i>Dimension</i>	<i>On Diagram</i>	<i>30°</i>	<i>45°</i>	<i>60°</i>	<i>75°</i>	<i>90°</i>
Stall width, parallel to aisle	a	18'	12.7'	10.4'	9.3'	9.0'
Stall depth to wall or abutment	b	17.3'	19.8'	21'	20.7'	19'
Aisle width between stall lines	c	11 [*]	13 [*]	18 [*]	23 [*]	26'
Stall depth interlock	d	13.4'	16.6'	18.7'	19.5'	—
Module, interlocking	e	37.8'	46.2'	55.4'	62'	—
<i>For 9.5 Foot Wide Stalls</i>						
		<i>Angle</i>				
<i>Dimension</i>	<i>On Diagram</i>	<i>30°</i>	<i>45°</i>	<i>60°</i>	<i>75°</i>	<i>90°</i>
<i>For 9.5 Foot Wide Stalls</i>						
		<i>Angle</i>				
<i>Dimension</i>	<i>On Diagram</i>	<i>30°</i>	<i>45°</i>	<i>60°</i>	<i>75°</i>	<i>90°</i>
Stall width, parallel to aisle	a	19'	13.4'	11'	9.8'	9.5'
Stall depth to wall or abutment	b	17.7'	20.1'	21.2'	20.8'	19'
Aisle width between stall lines	c	11 [*]	13 [*]	18 [*]	20 [*]	25'
Stall depth interlock	d	13.6'	16.8'	18.8'	19.6'	—
Module, interlocking	e	38.2'	46.6'	55.7'	59.2'	—

*THE MINIMUM AISLE WIDTH FOR TWO-WAY TRAFFIC IS TWENTY FOUR (24) FEET.

ZONING CODE

Diagram C

(1) ACCESS DRIVE GRADE AT STREET R/O/W

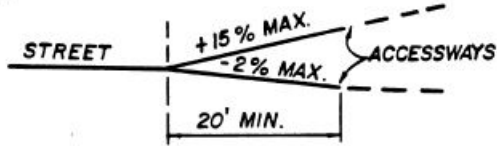

(2) DRIVEWAY OR PARKING STRUCTURE RAMP

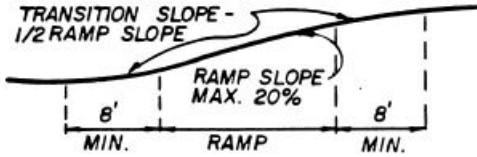

TRANSITIONS REQUIRED ONLY IF RAMP SLOPE EXCEEDS 10%

ACCESS DRIVES AND PARKING AISLES

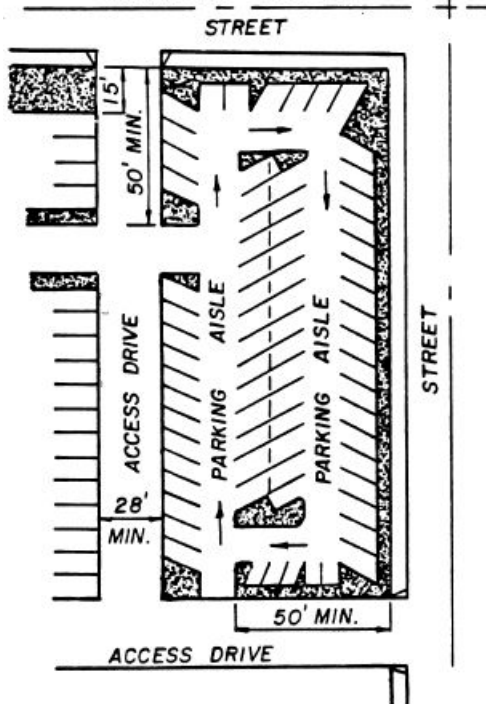

(3) MAXIMUM PARKING STALL AND PARKING AISLE GRADES

PROFILE

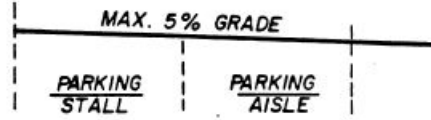

PLAN VIEW

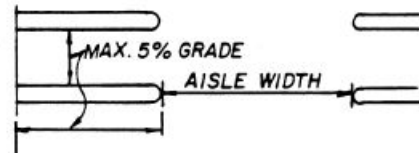

PARALLEL PARKING

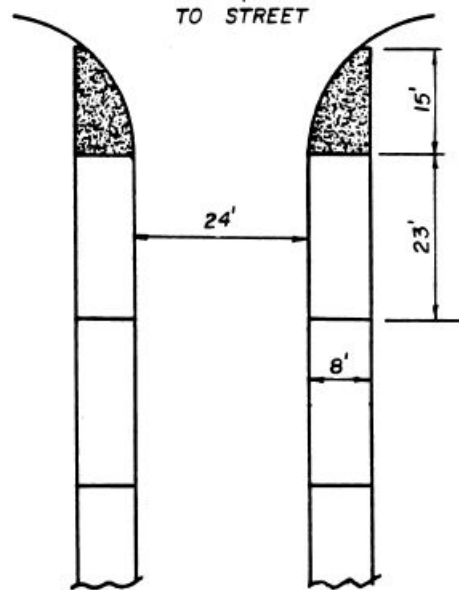

BREA CODE

Diagram D

Refer to § 20.08.040.E.

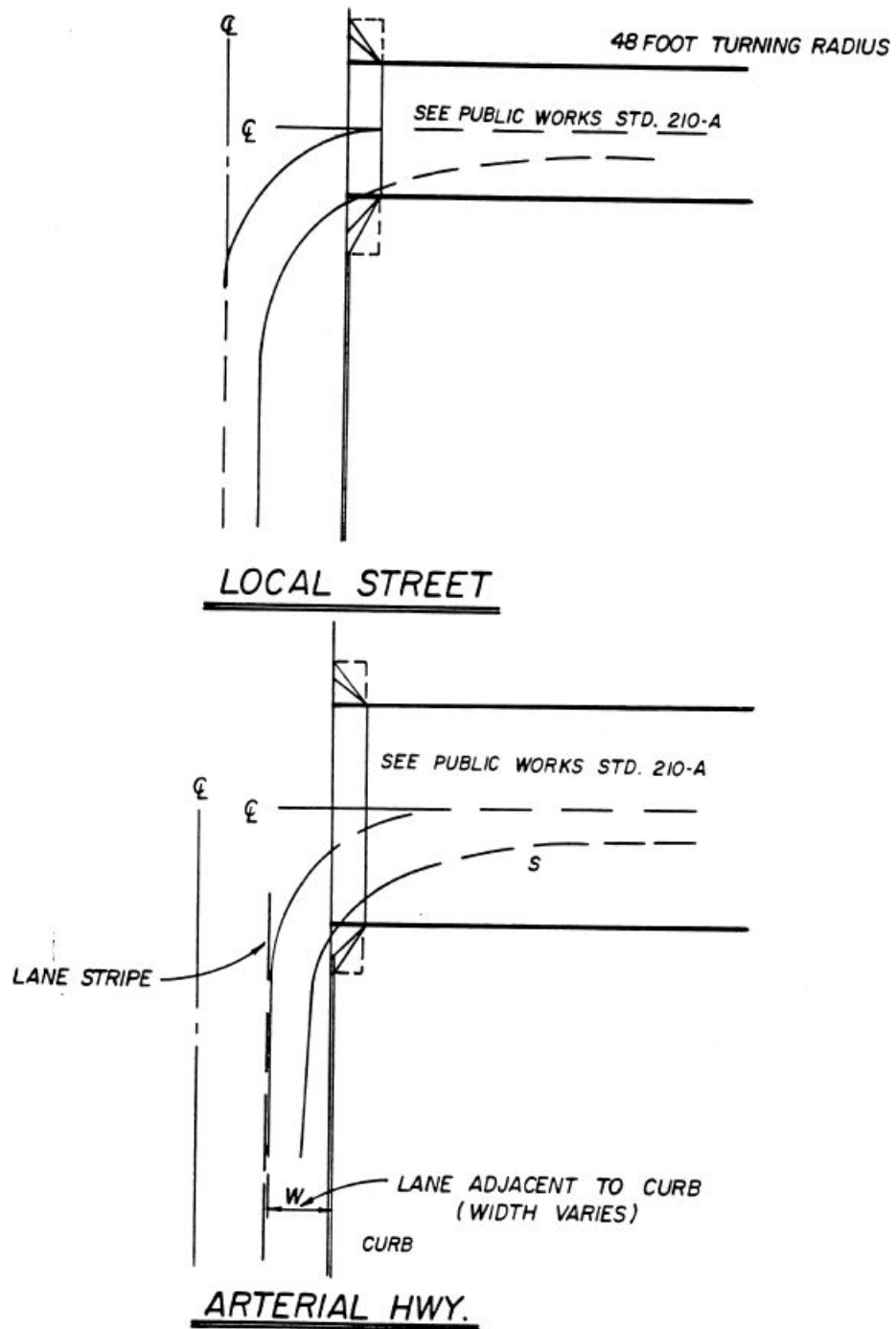

ZONING CODE

Diagram E

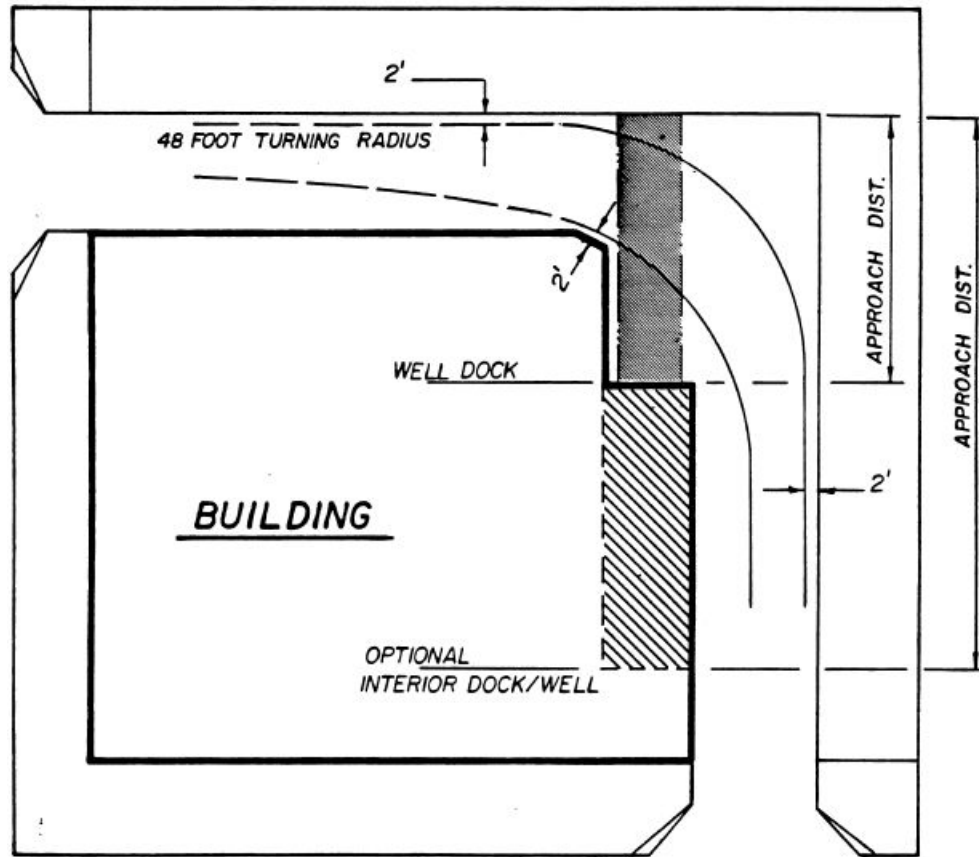



-  SEMI-TRAILER DOCK APPROACH - FOR WIDTH AND LENGTH SEE SECTION 304.050
-  OPTIONAL INTERIOR TRUCK WELL

Diagram F



SEMIRTRAILER WHEEL TRACK

48' TURNING RADIUS (30 SCALE)

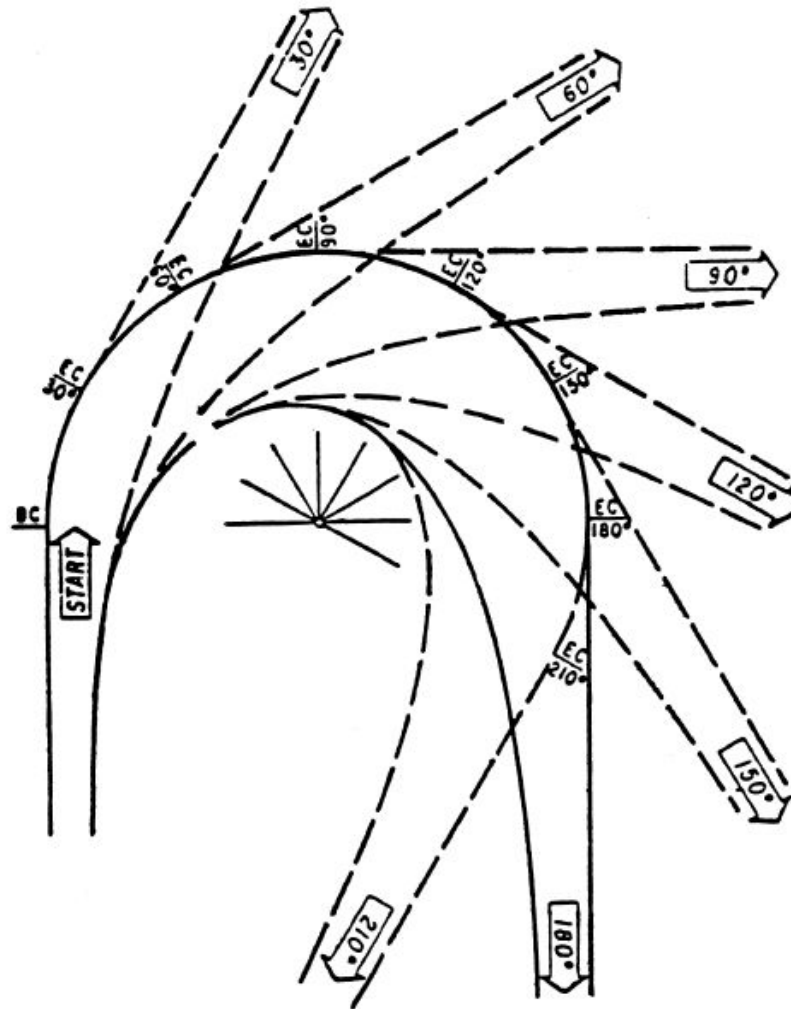
ZONING CODE

Diagram G

LEGEND
B - BASKET OVERHANG
LF - LEFT FRONT WHEEL
LB - LEFT REAR BUMPER
RR - RIGHT REAR WHEEL

LEGEND
B - BASKET OVERHANG
RF - RIGHT FRONT WHEEL
RB - RIGHT REAR BUMPER
LR - LEFT REAR WHEEL

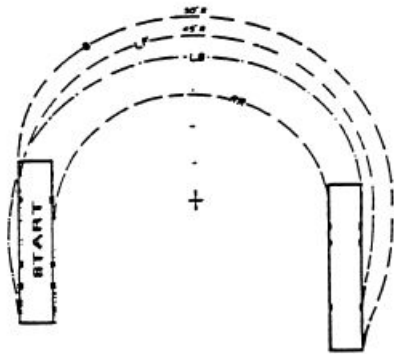

SPARTAN LTI ELEVATING PLATFORM
(TRUCK)

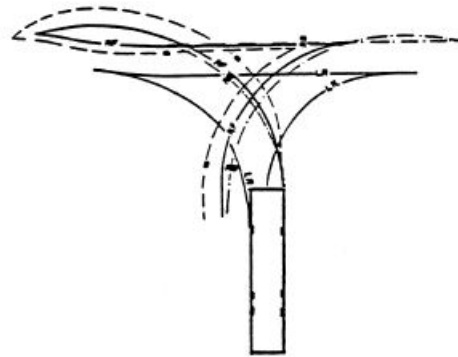

SPARTAN LTI ELEVATING PLATFORM
(TRUCK)
HAMMERHEAD TURNAROUND