

ZONING

120 Attachment 1

Village of Nassau

Exhibit A: Plates 1 through 32

PLATE 1

Lot in Single Ownership

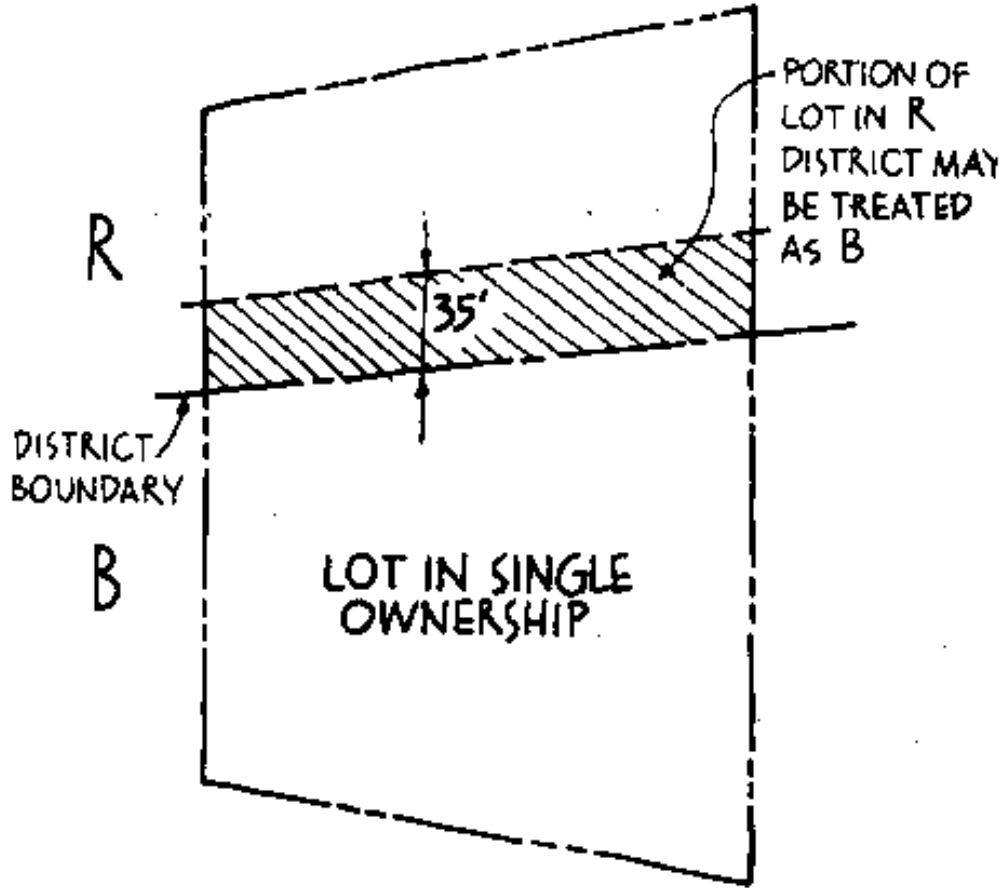

NASSAU CODE

PLATE 2  
Alley; Net Land Area; Block



ALLEY

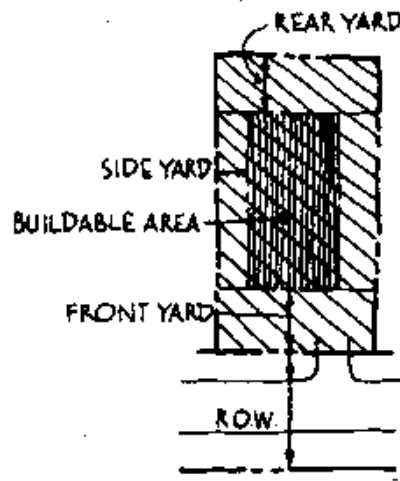

NET LAND  
AREA

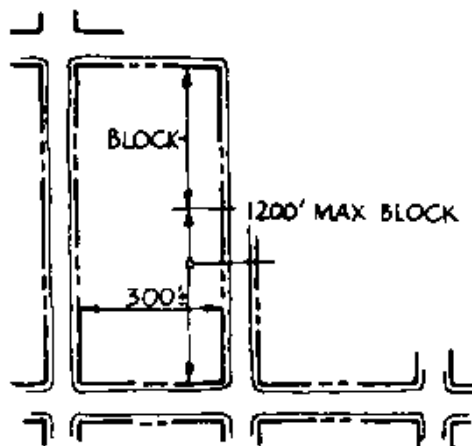

BLOCK

ZONING

PLATE 3  
Building Height

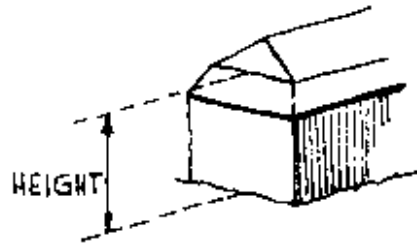

MANSARD

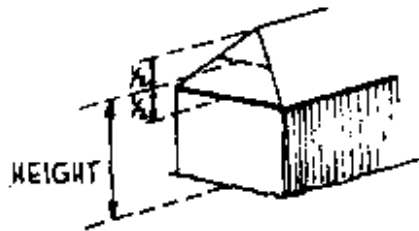

HIP

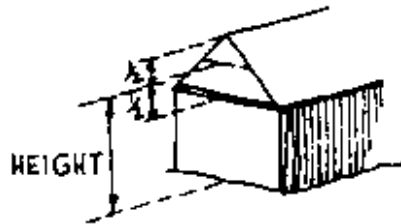

GABLE

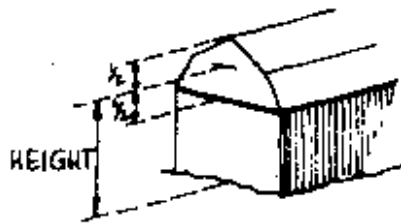

GAMBREL

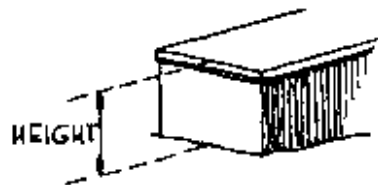

FLAT

BUILDING HEIGHT

NASSAU CODE

PLATE 4  
Story; Street Line; Center Line



STORY

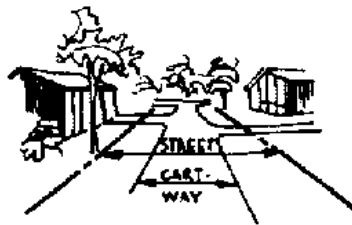

STREET LINE

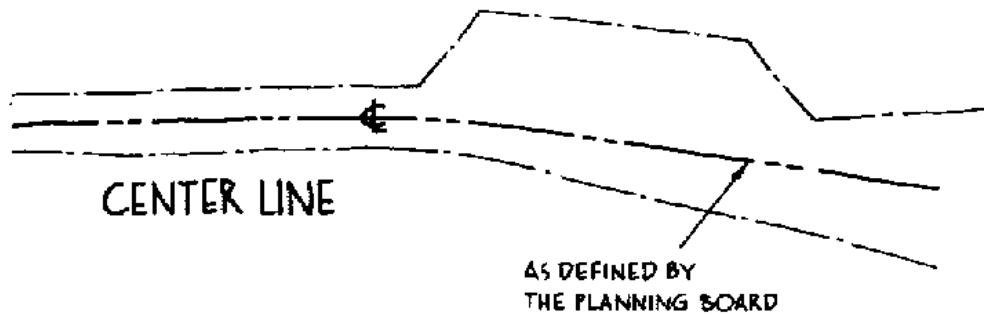

ZONING

PLATE 5  
Court; Dwellings

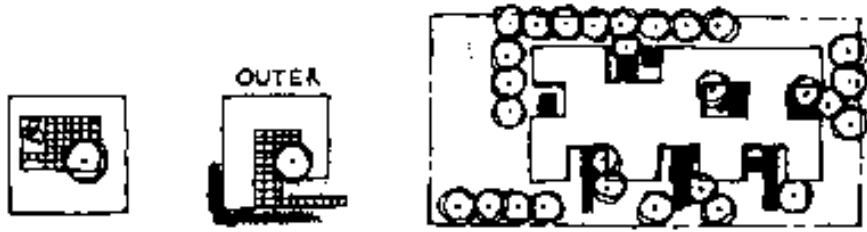

COURT



ONE FAMILY



TWO FAMILY



MULTI FAMILY



ROW or TOWN HOUSE

NASSAU CODE

PLATE 6  
Floor Area Ratio

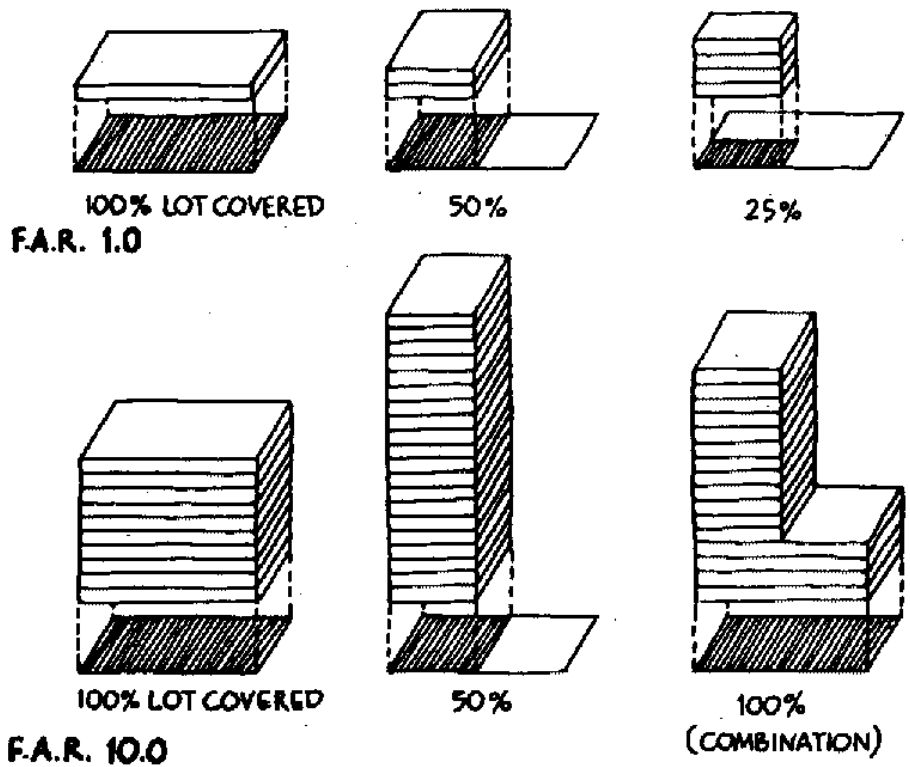

FLOOR AREA RATIO

ZONING

PLATE 7

Semidetached; Family; Public/Private Garage; Lot

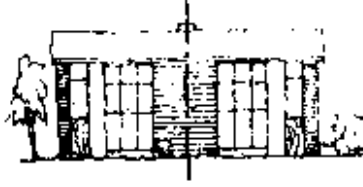

SEMI DETACHED



FAMILY



GARAGE

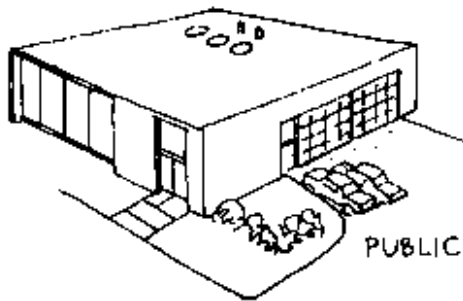

LOT

NASSAU CODE

PLATE 8  
Corner Lot; Mobile Home; Mobile Home Park; Motel

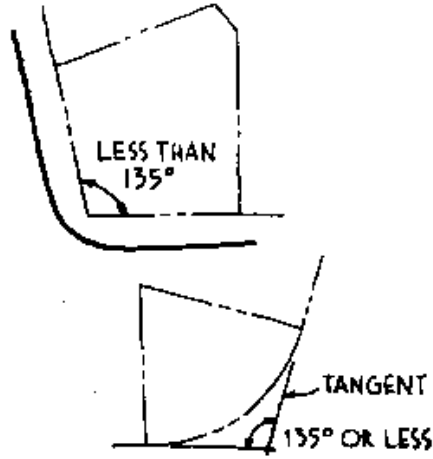

CORNER LOT

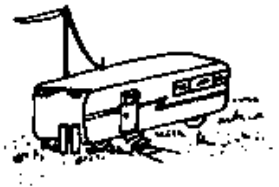

MOBILE HOME

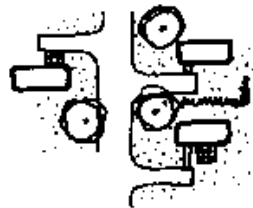

MOBILE HOME  
PARK

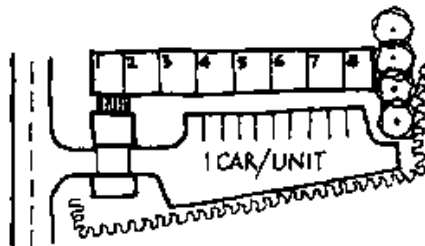

MOTEL

ZONING

PLATE 9

Through Lot; Lot Width Village of Nassau

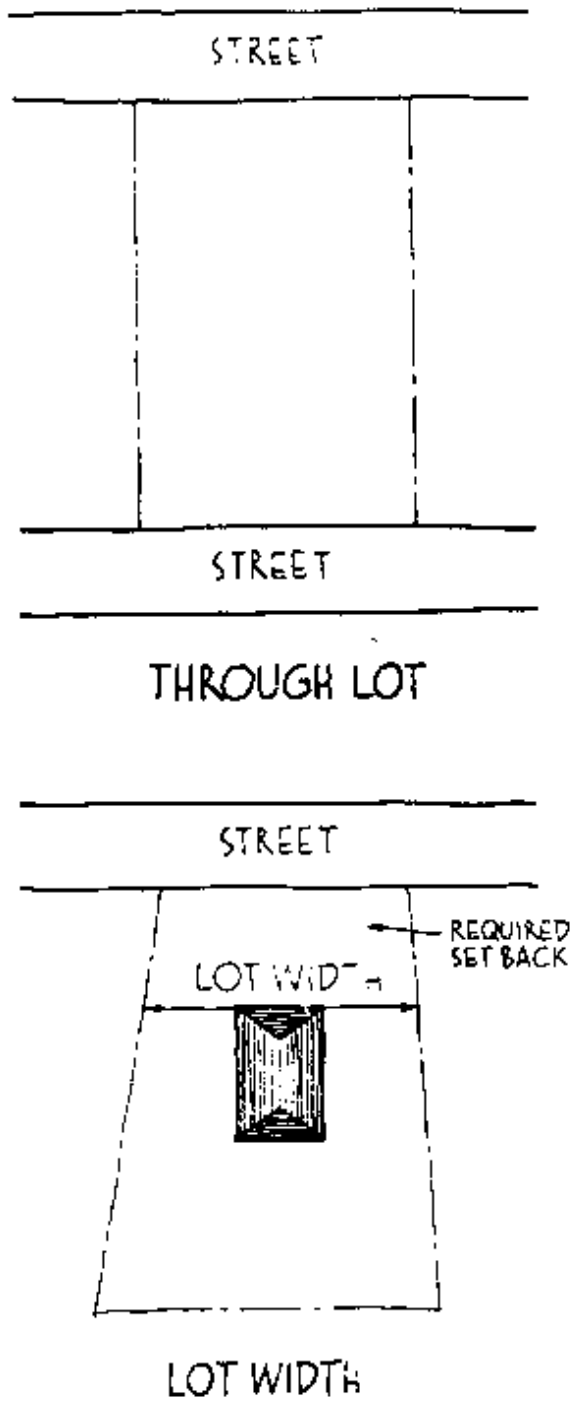

NASSAU CODE

**PLATE 10**  
**Motor Vehicle Service Station**

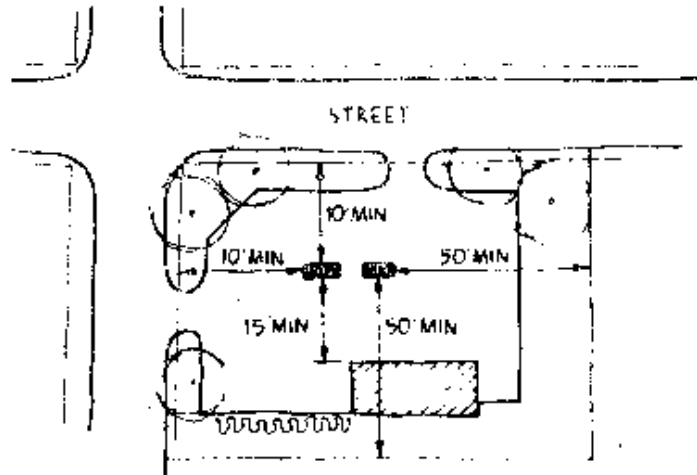
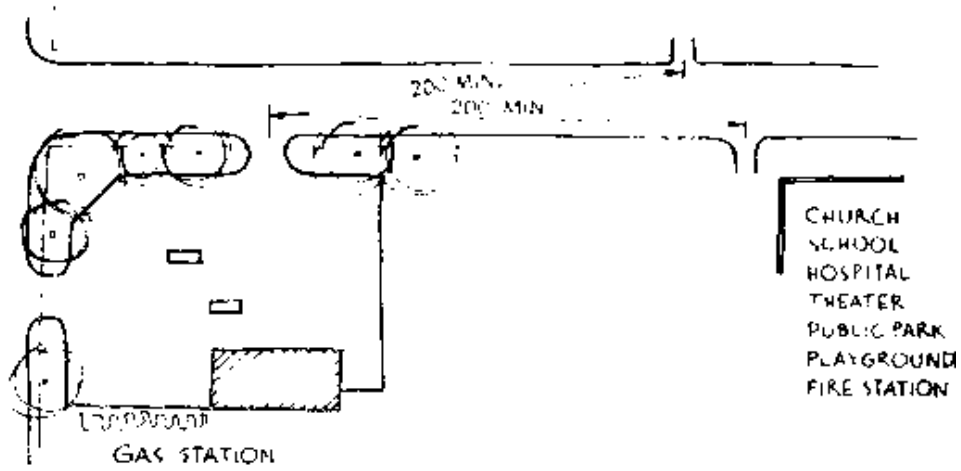

MOTOR VEHICLE SERVICE STATION

ZONING

PLATE 11  
Signs

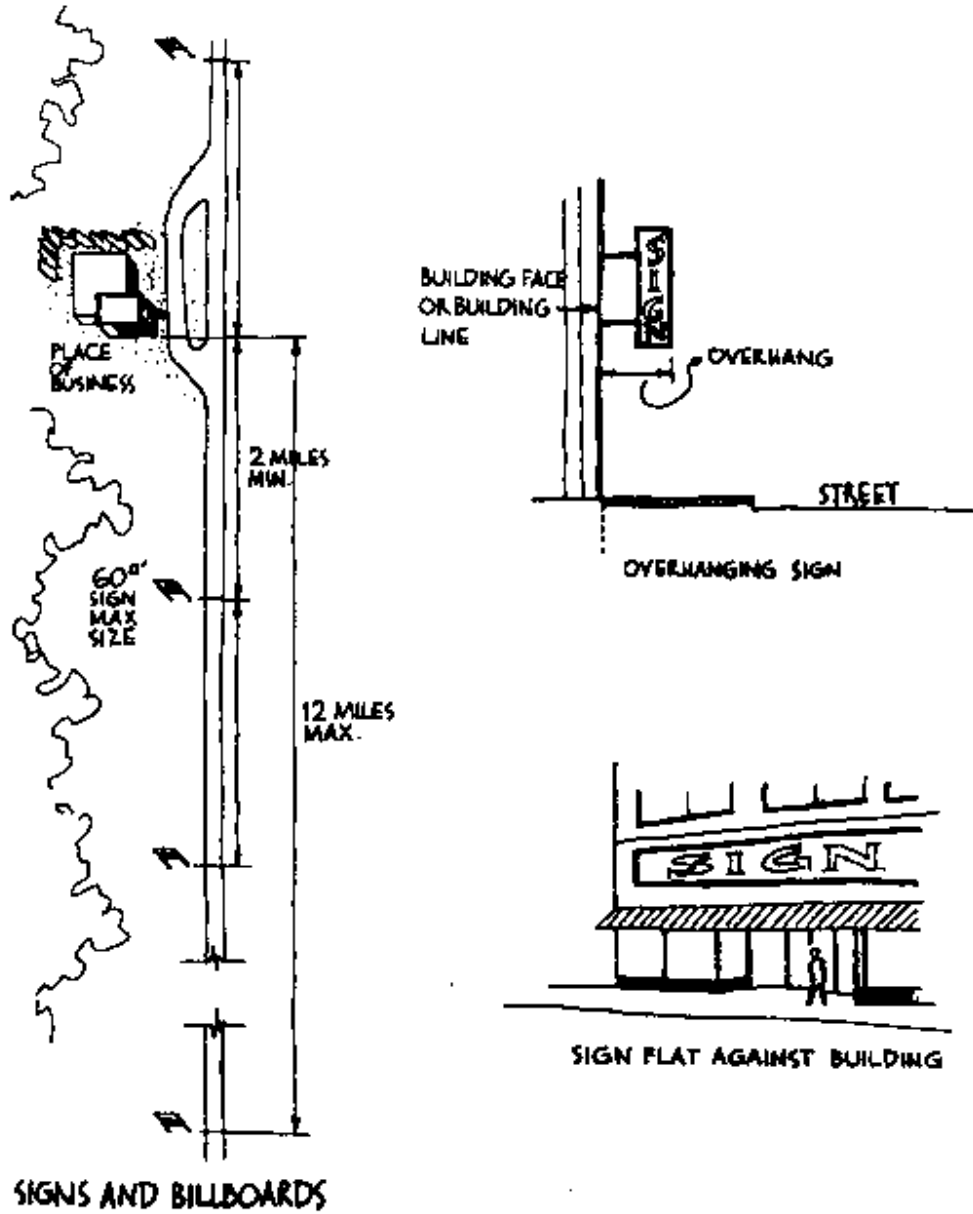
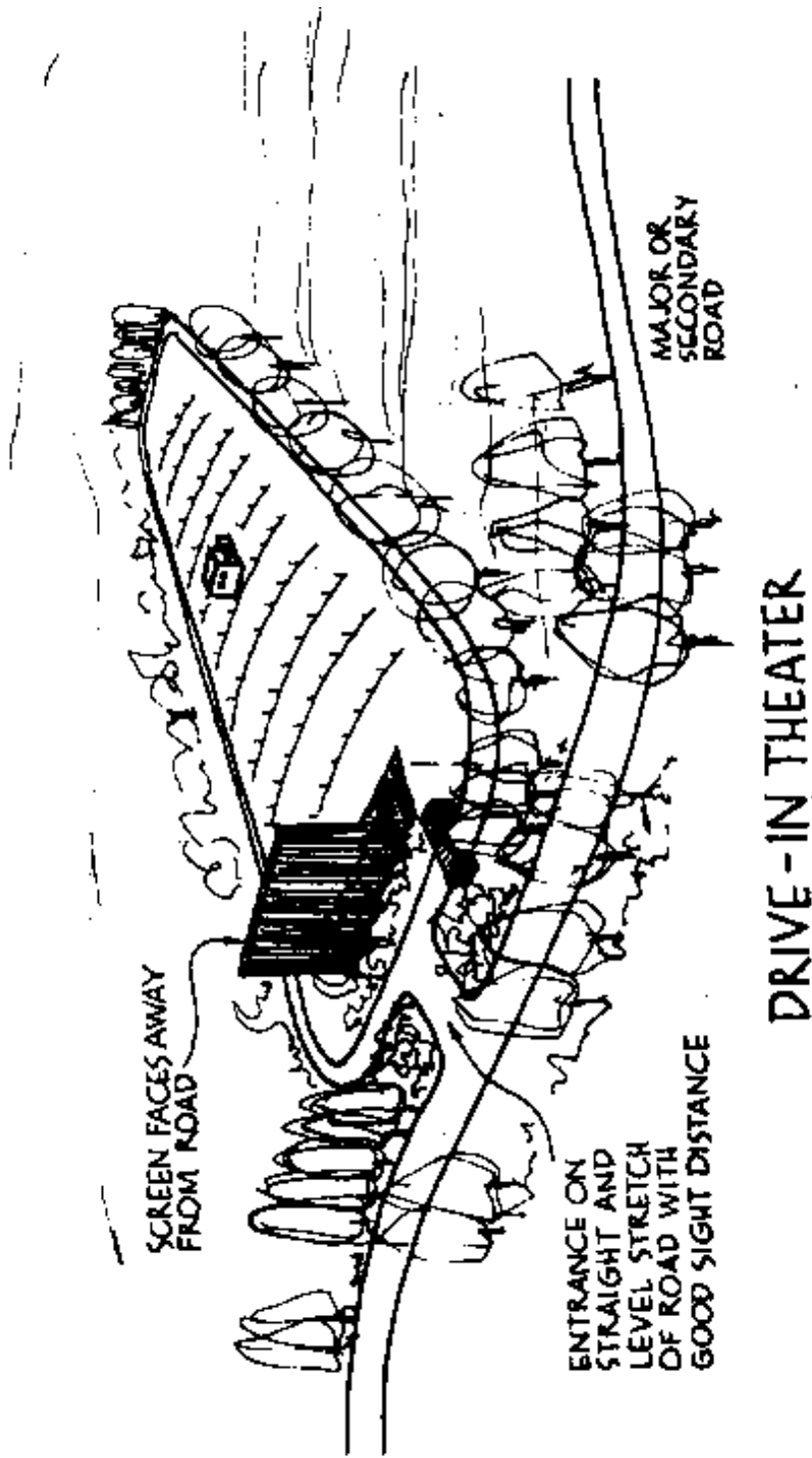
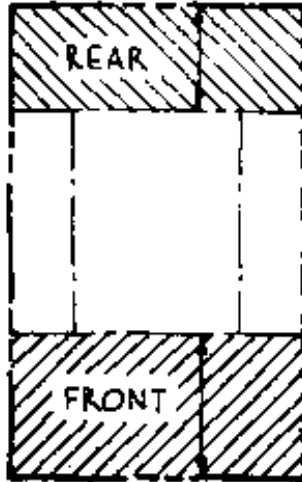

PLATE 12  
Drive-In Theater



ZONING

PLATE 13  
Front, Rear and Side Yards



---

FRONT & REAR  
YARD

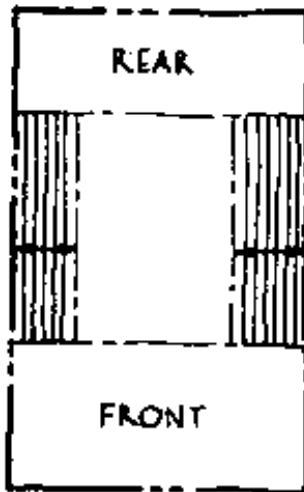

SIDE YARD

NASSAU CODE

PLATE 14  
Rural Residential District

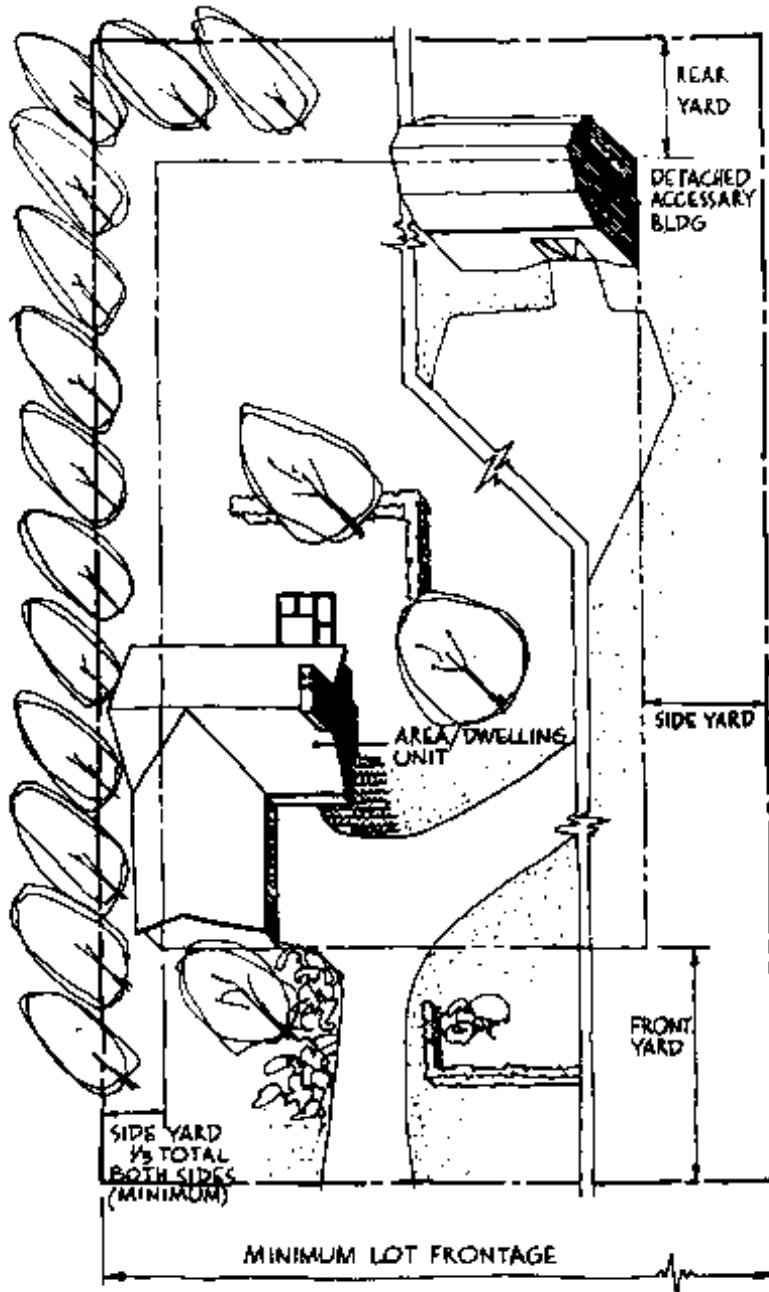

RURAL RESIDENTIAL

ZONING

PLATE 15  
Between the Yards

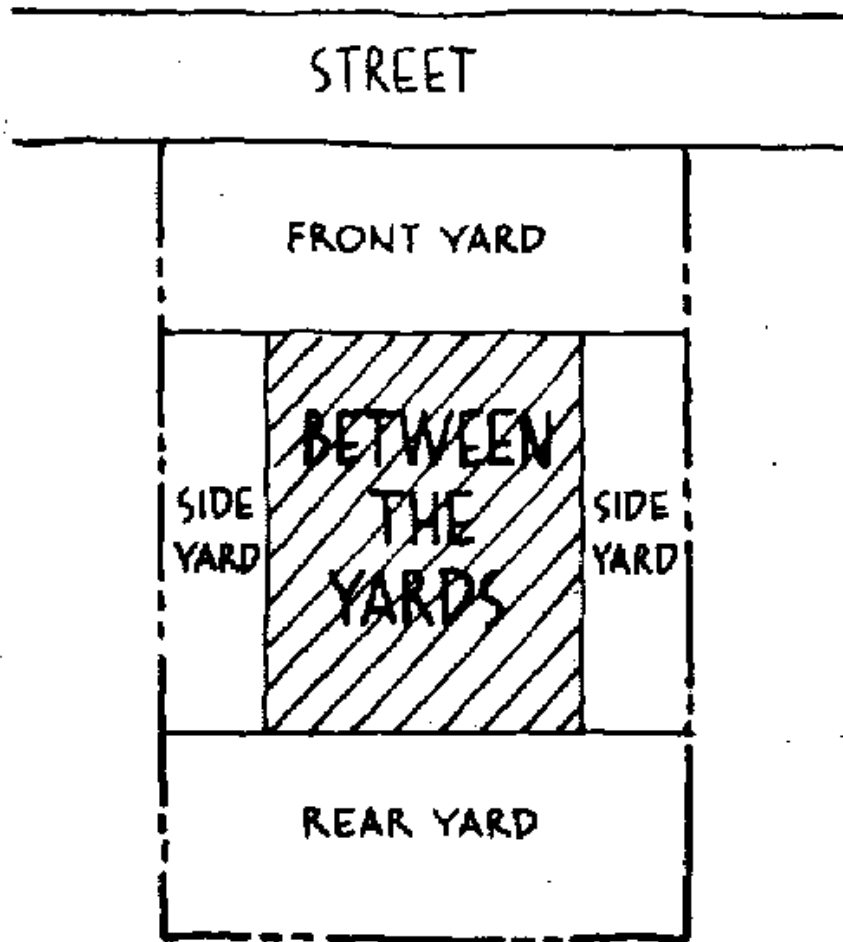

NASSAU CODE

PLATE 16  
Off-Street Parking

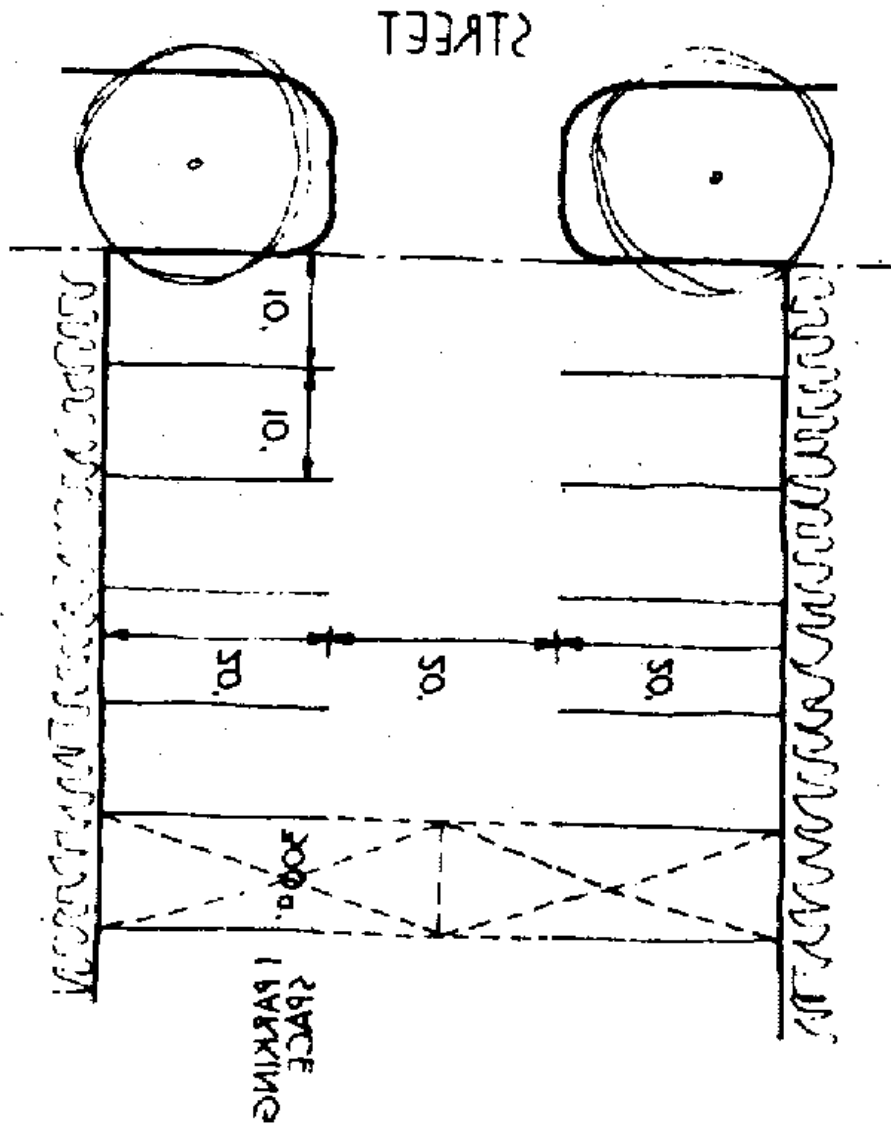

ZONING

PLATE 17  
Five and 100 Acres

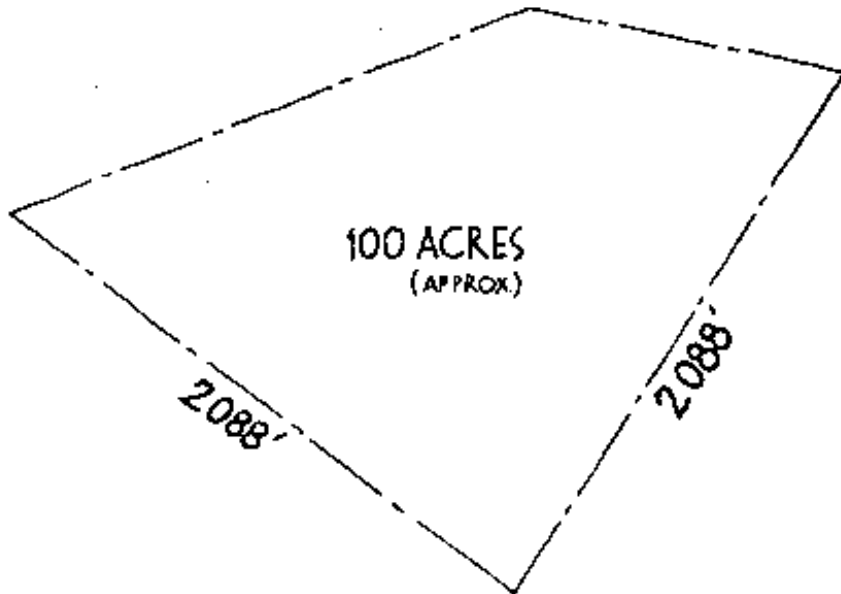
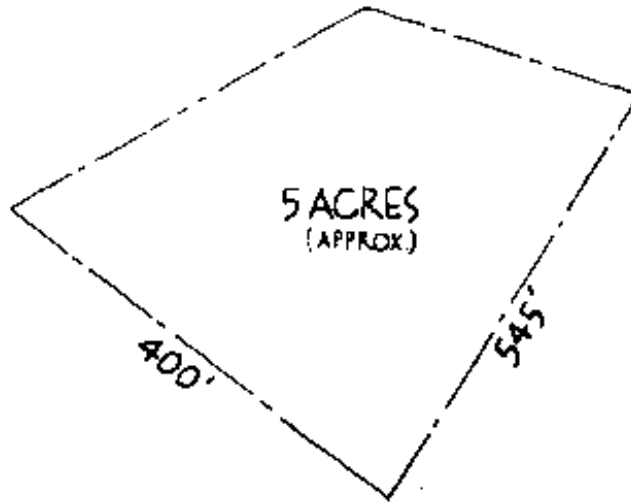

NASSAU CODE

PLATE 18  
Location of Driveways

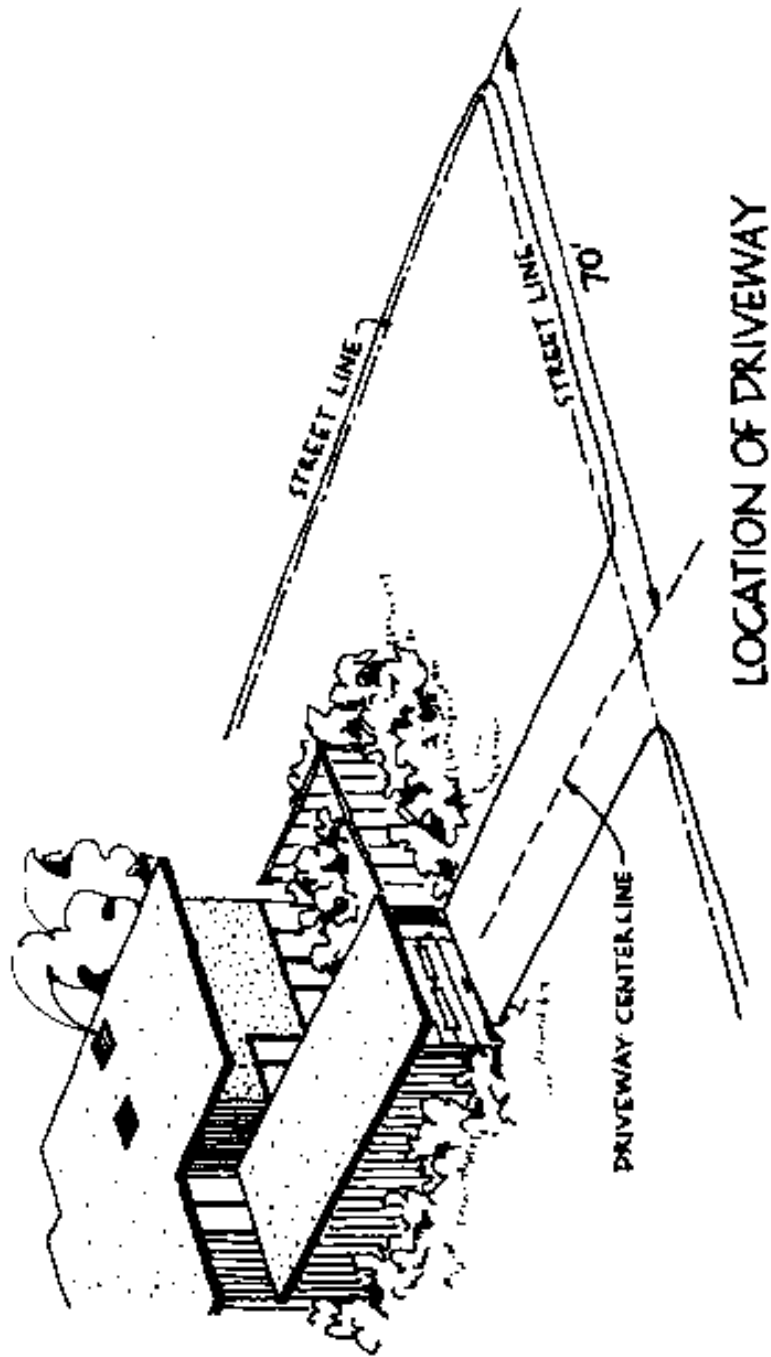

ZONING

PLATE 19  
Single-Family Residential District

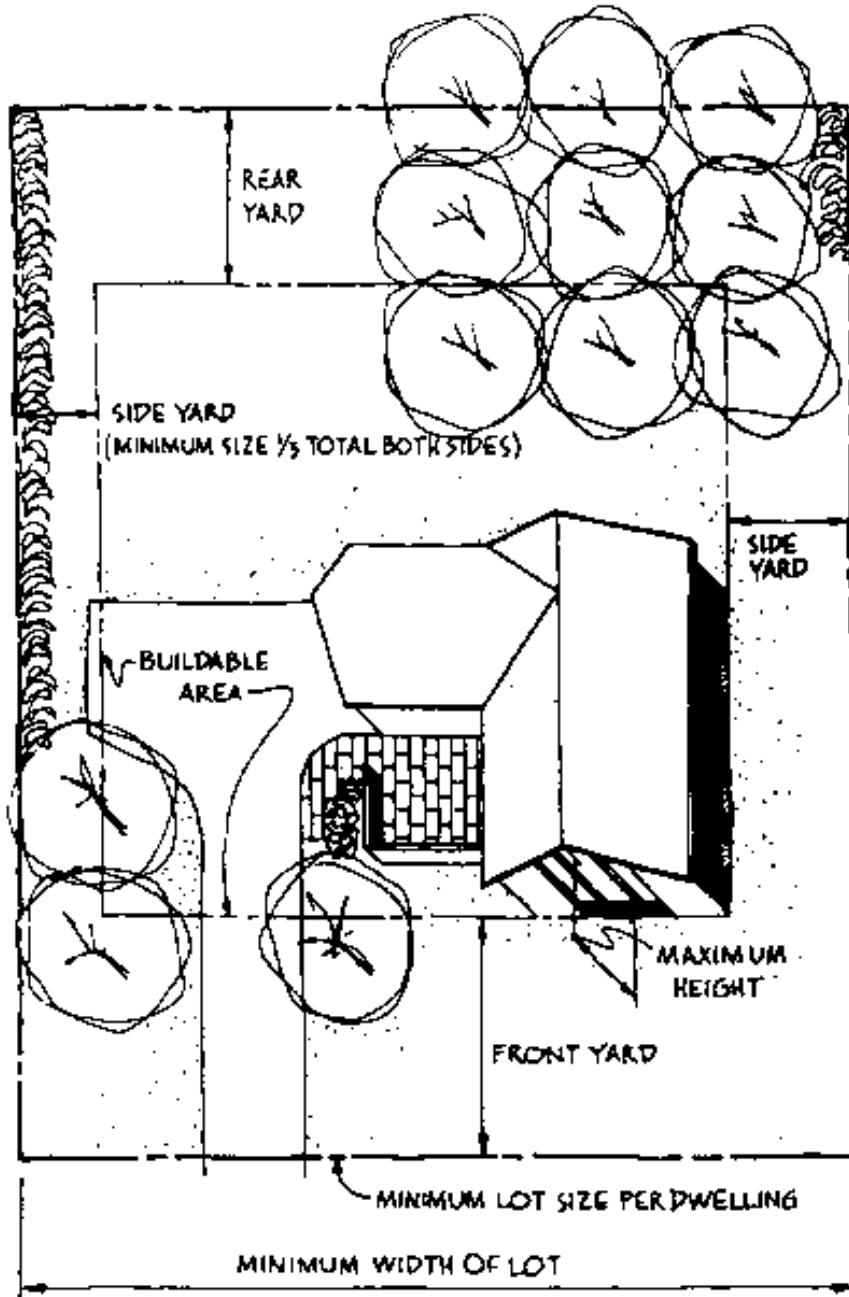

SINGLE FAMILY RESIDENTIAL

NASSAU CODE

PLATE 20  
One Acre

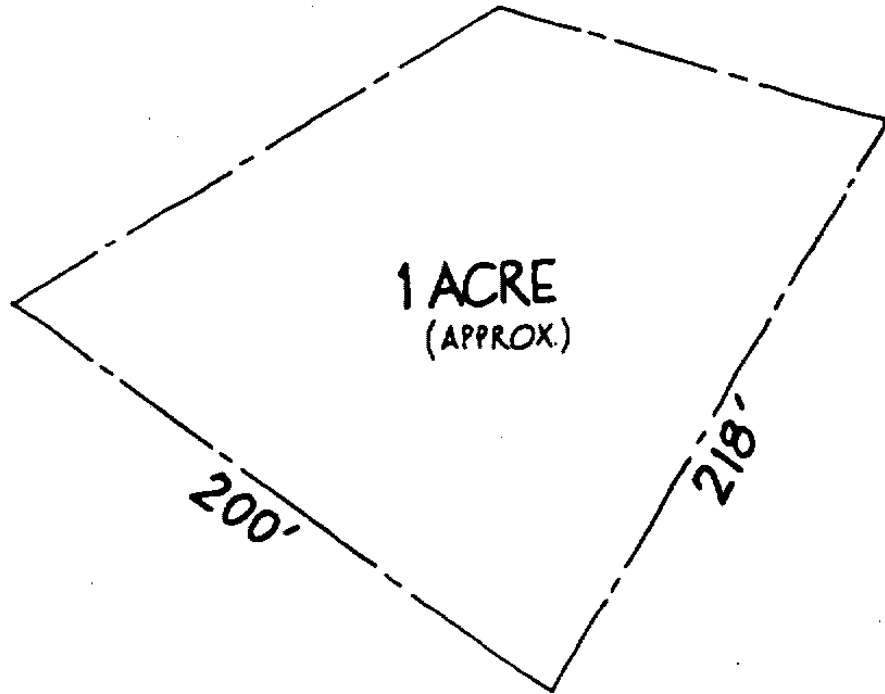

ZONING

PLATE 21  
Cluster Development

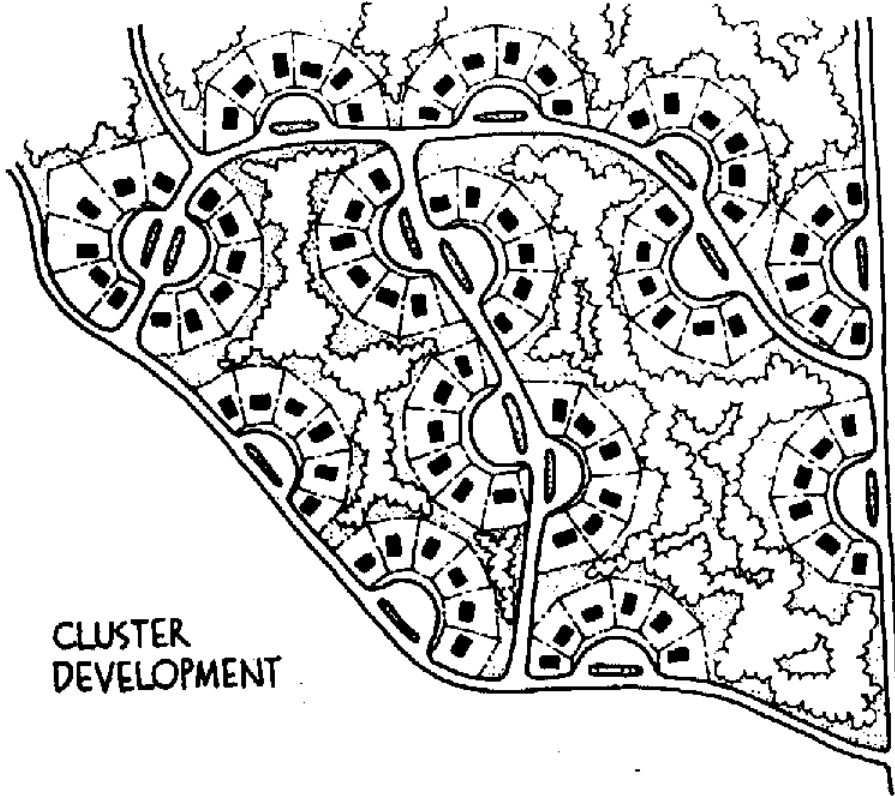

NASSAU CODE

PLATE 22  
Private or Commercial Parking Lot

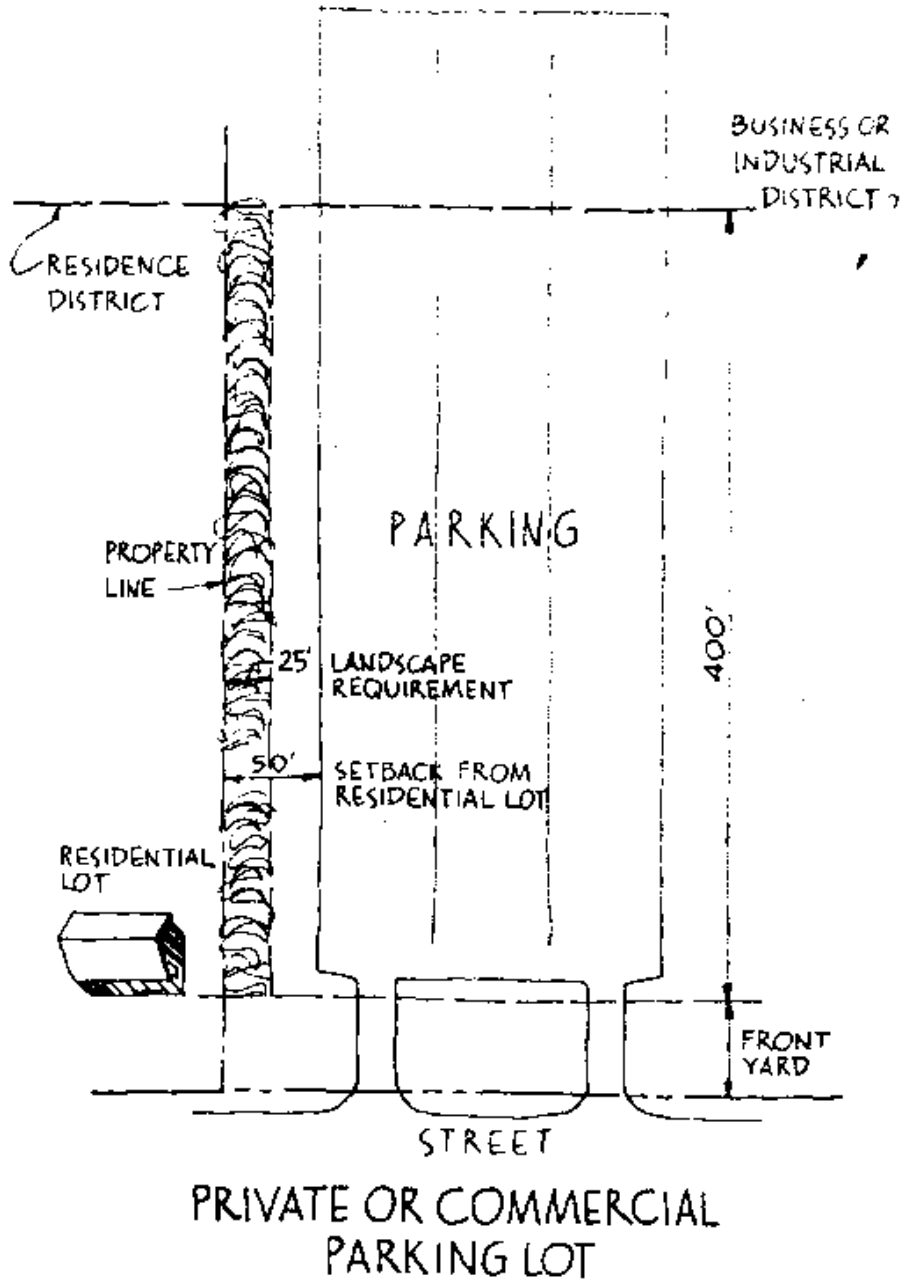

ZONING

PLATE 23  
Three Acres

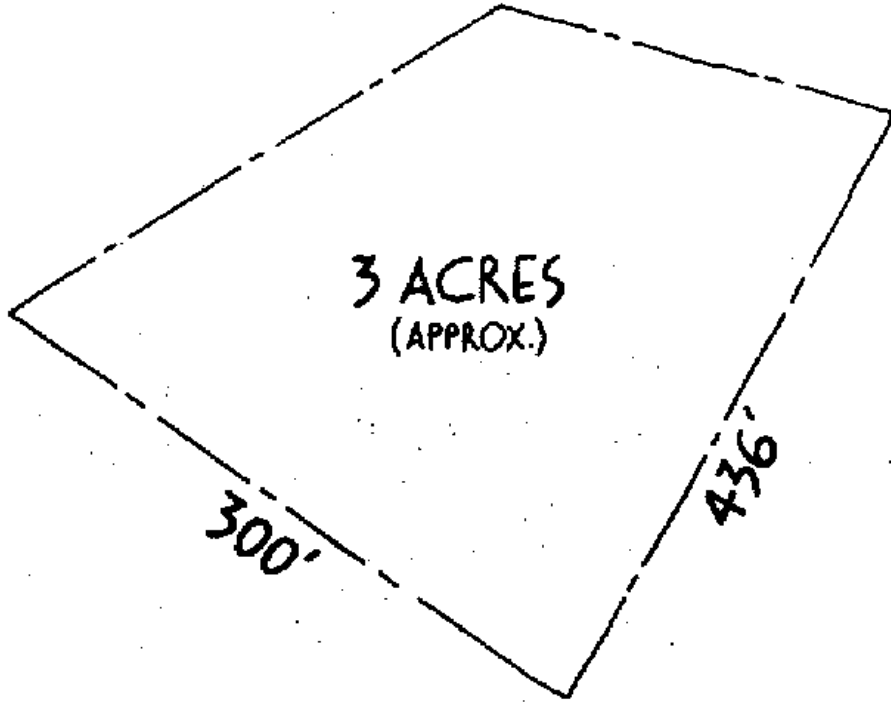

NASSAU CODE

PLATE 24  
Nonresidential Use in a  
Residential District

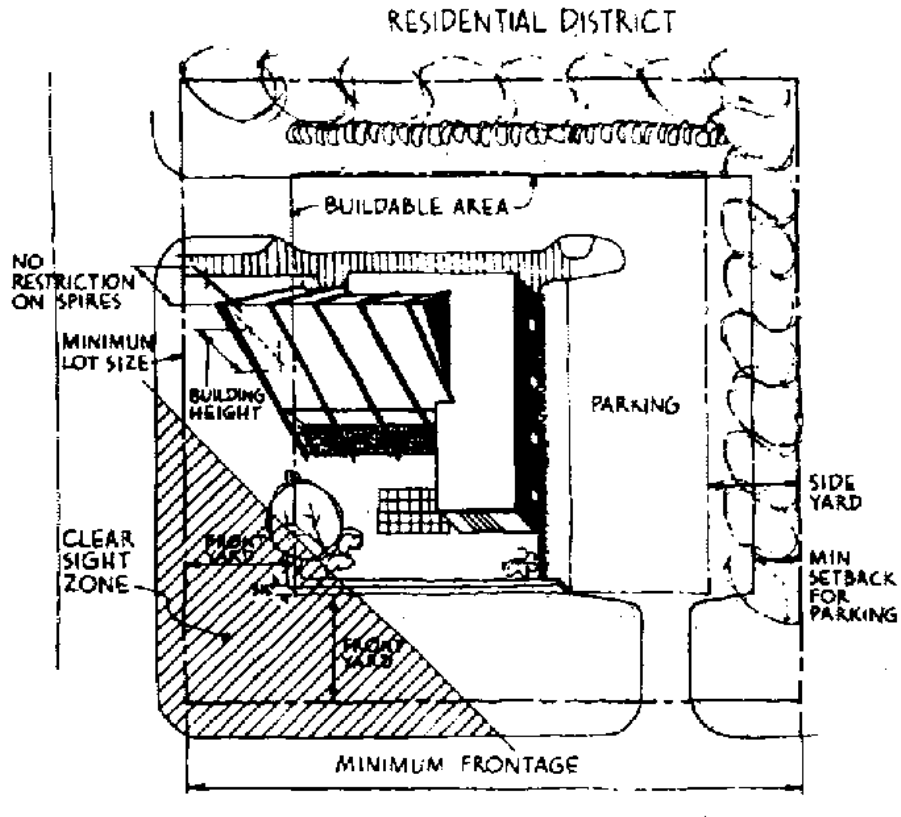

NON RESIDENTIAL USE IN  
A RESIDENTIAL DISTRICT

ZONING

PLATE 25  
Loading Dock

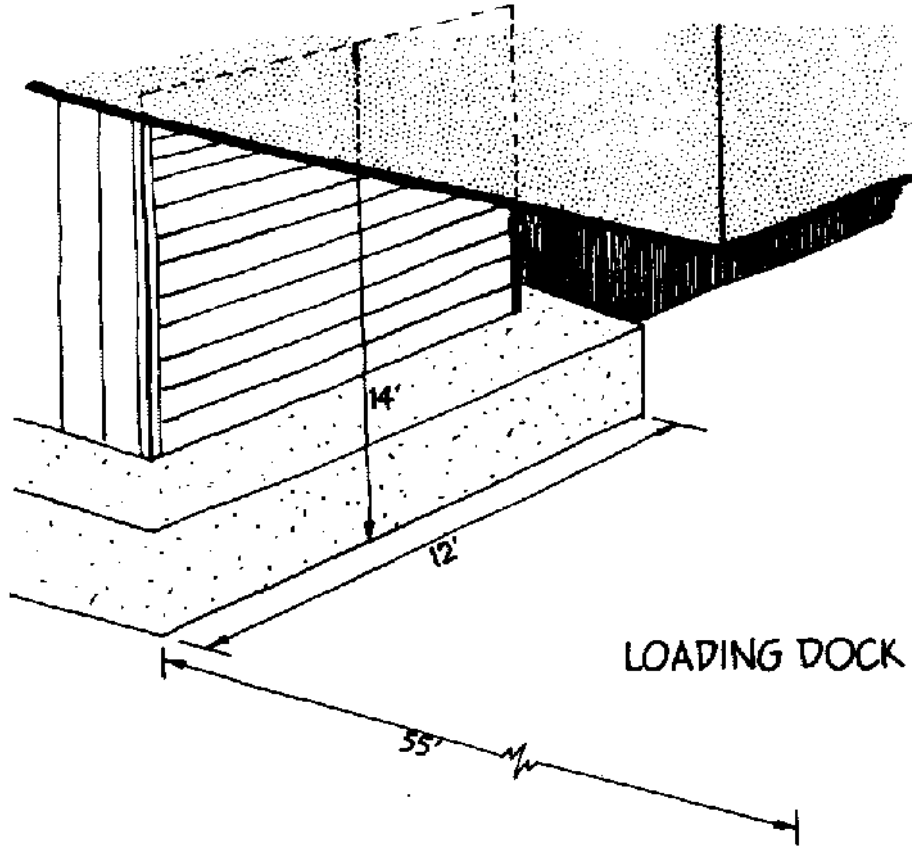

NASSAU CODE

PLATE 26  
Spacing of Entrances and Exits

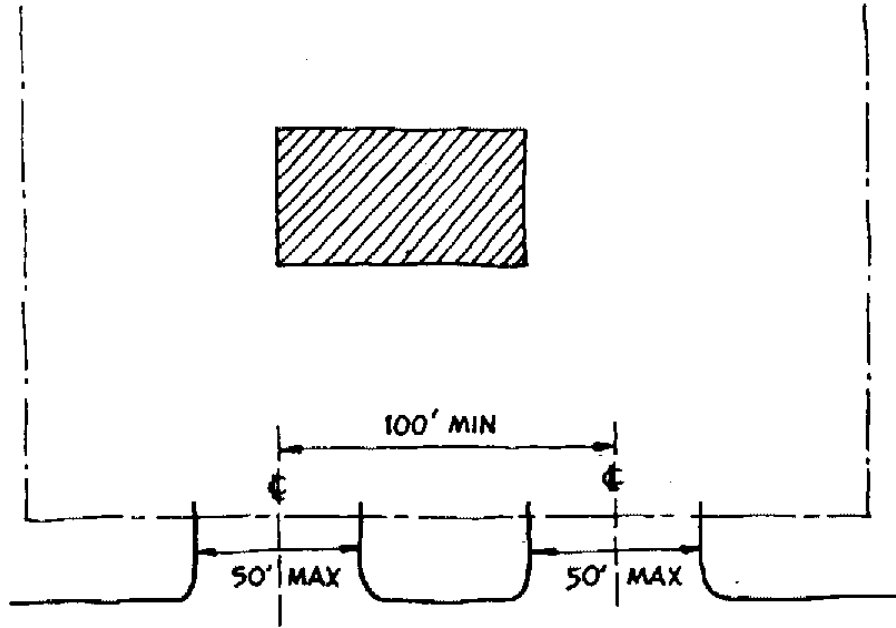

SPACING OF ENTRANCES AND EXITS

ZONING

**PLATE 27**  
**Planned Development**

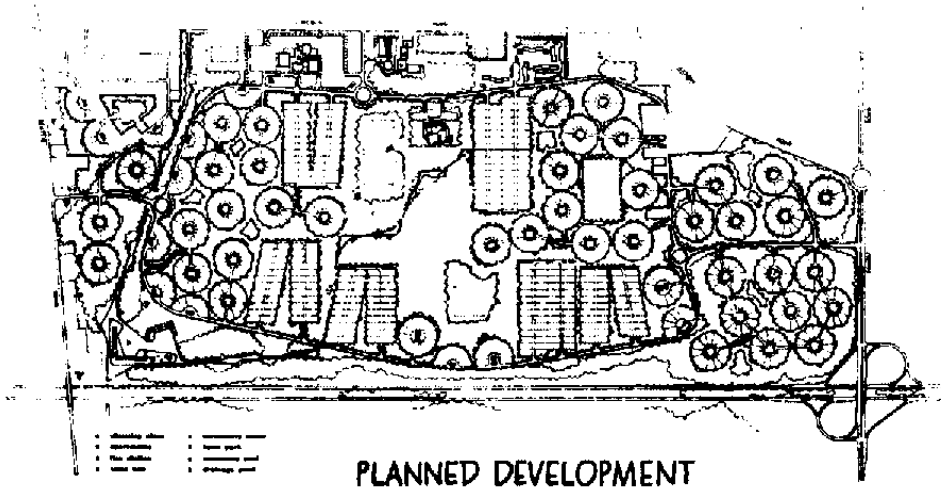

NASSAU CODE

PLATE 28  
Access of a Commercial or  
Industrial Use

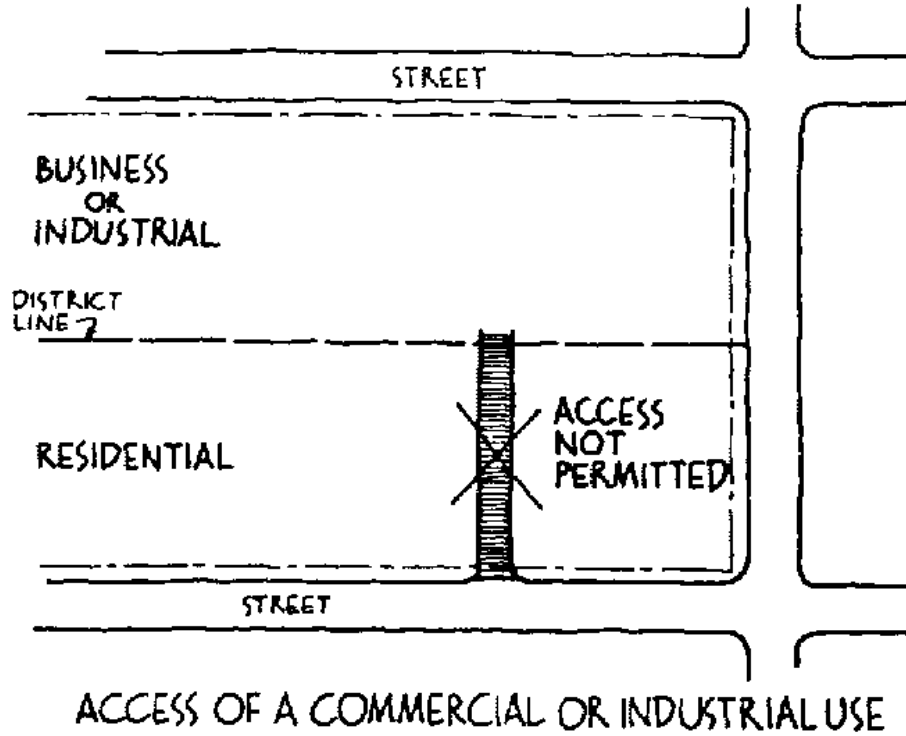

ZONING

PLATE 29  
Individual Sewerage Systems

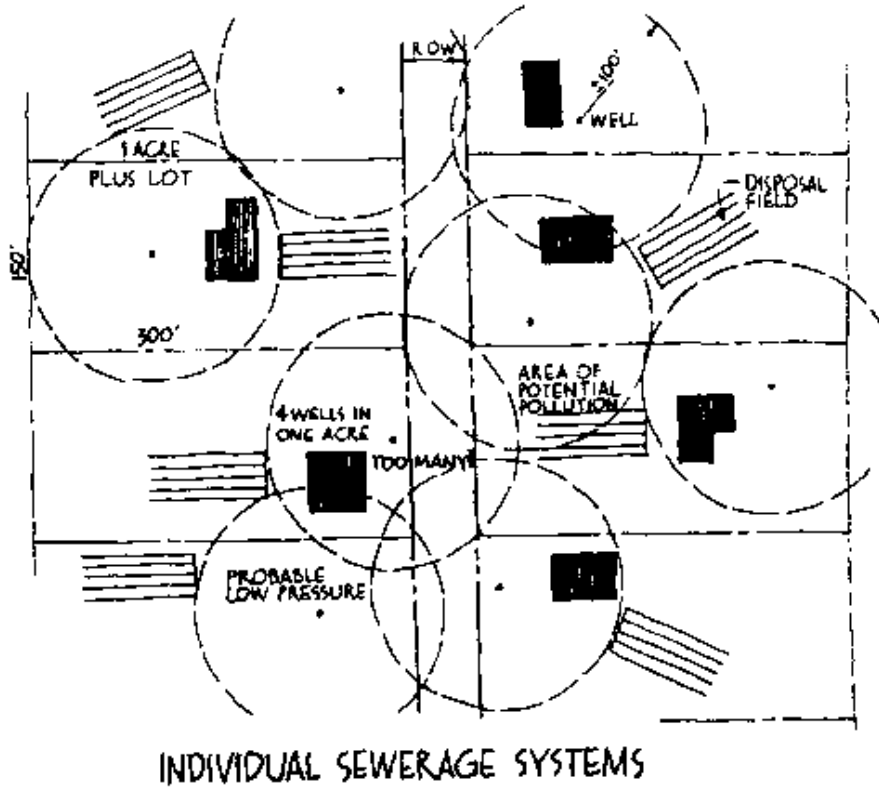

NASSAU CODE

**PLATE 30**  
**Sight Distance**  
**Village of Nassau**

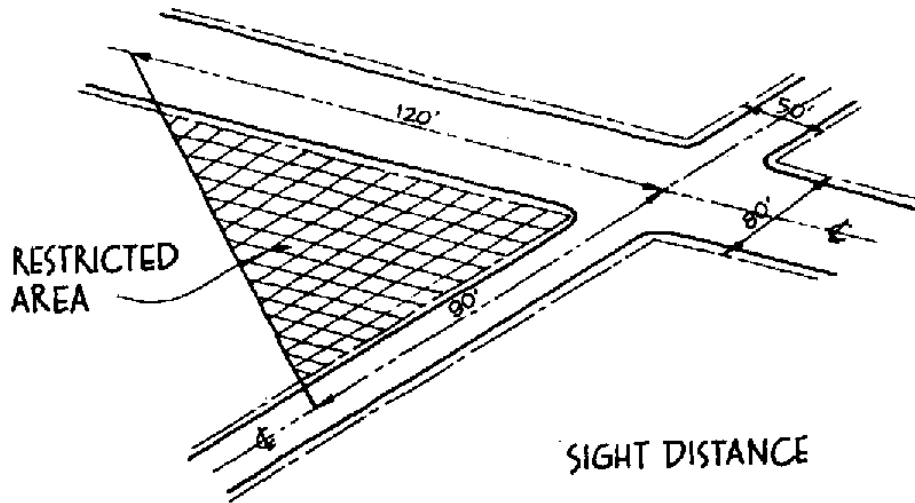

ZONING

PLATE 31  
Apartment House; Hospital

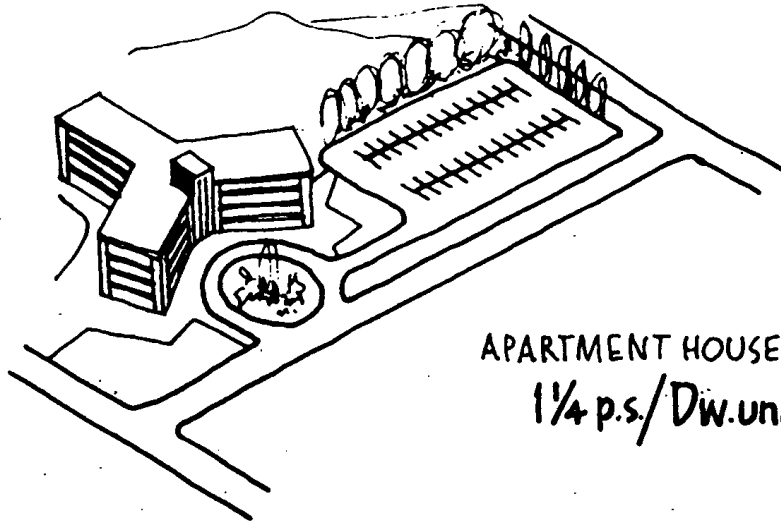

APARTMENT HOUSE  
1 1/4 p.s./Dw.unit

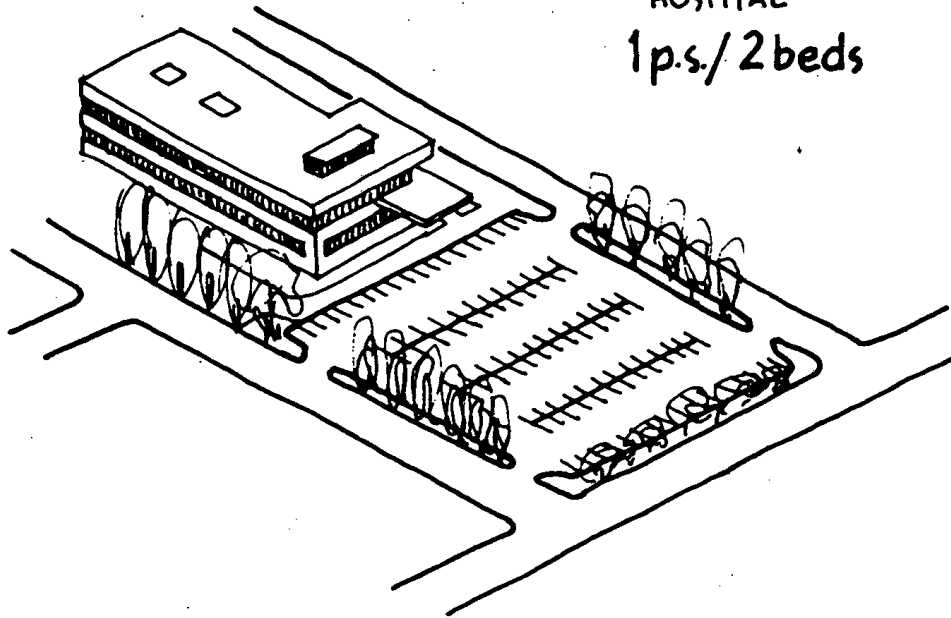

HOSPITAL  
1 p.s./2 beds

NASSAU CODE

PLATE 32  
Private Garage on Steep Slopes

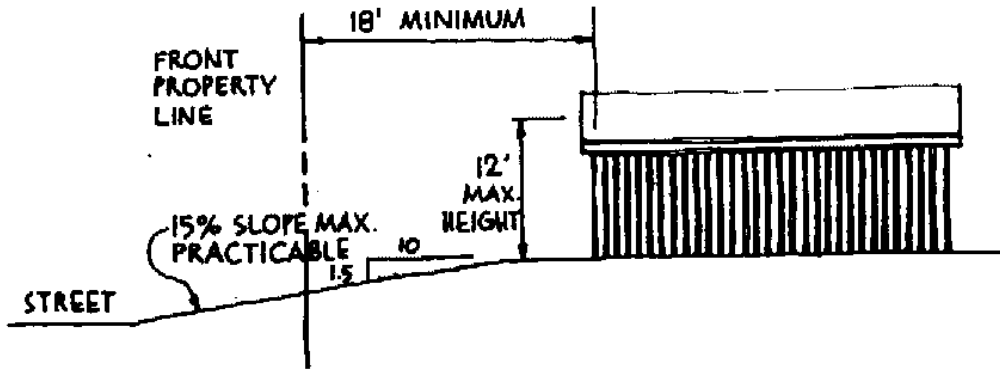

PRIVATE GARAGE ON STEEP SLOPES